

HOCHDRUCK KÜHL-SCHMIERSTOFF-LEITUNGSSYSTEM
AUS ROSTFREIEM STAHL

*HIGH-PRESSURE COOLING-LUBRICANT-SUPPLY SYSTEM
IN STAINLESS STEEL*

Hirt[®]
LINE

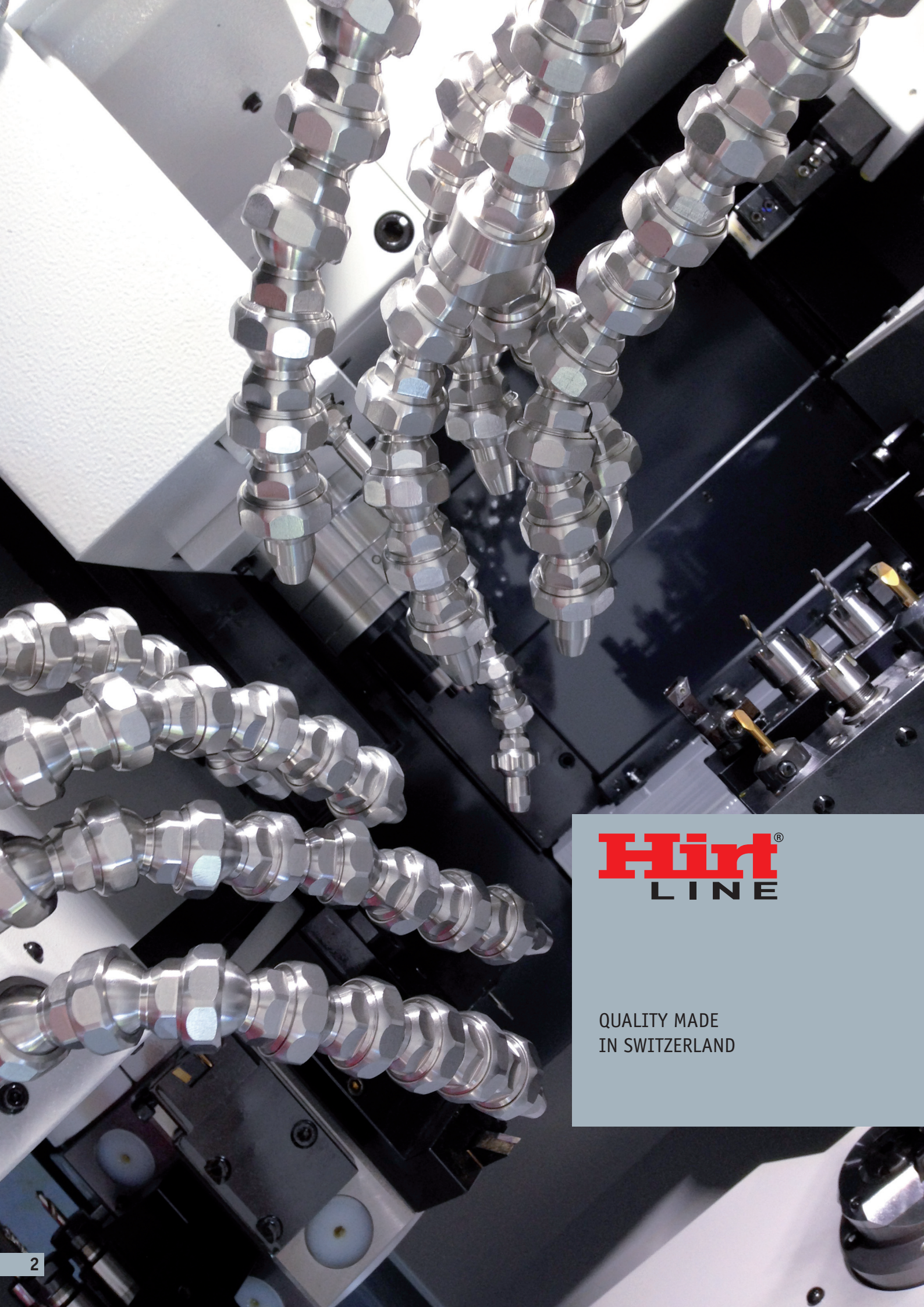



Hirt[®]
LINE

QUALITY MADE
IN SWITZERLAND

Kühl-Schmierstoff-Leitungssystem aus rostfreiem Stahl

Das Originale Gelenkschlauch System | Hirt-Line®

Unser Gelenkschlauchsystem ist beliebig ausbaubar, rostfrei und bietet eine hohe Lebensdauer. Die Einzelteile sind präzisionsgefertigt und unempfindlich gegen Wärme und chemische Substanzen. Sie lassen sich einfach von Hand zusammenschrauben, anpassen, verlängern und kürzen. Weder Kühlmitteldruck noch Maschinenvibrationen können die Position verändern. Druckbeständigkeit über 100 bar. Geeignet für Drehmaschinen, Fräsmaschinen, Schleifmaschinen, Luftkühlungen und einsetzbar in der chemischen Industrie.

Cooling-lubricant-supply system of stainless steel

The Original Modular Hose System | Hirt-Line®

Our jointed hose is developable, stainless and processed for a long life. The individual parts are precision engineered and resistant to heat and chemicals. Can easily be screwed together by hand, be adapted, lengthened and shortened to your needs. No coolant pressure or machine vibrations can change the position. It's pressure resistant up to 100 bar. Suitable for lathes, milling machines, grinders, air cooling systems and can be used in the chemical industry.



Kühlung ganz individuell und flexibel

Kunststoff-Gelenkschläuche sind zwar sehr flexible Kühlmittel-Leitungen, bieten aber nur bedingt die geforderte Betriebssicherheit. Standard Gelenkschläuche werden häufig durch Vibrationen oder Späne verstellt und das Kühlmittel gelangt nicht mehr dahin, wo es von Nutzen ist. Maschinenstillstände bis hin zu Werkzeugschäden sind teuer und können vermieden werden. Mit unserem herstellerunabhängigen Hirt-Line® Kühl-Schmierstoff-Leitungssystem für Dreh-, Fräs- und Schleifmaschinen steigern Sie Ihre Produktivität.

MADE IN SWITZERLAND ist das Qualitätsversprechen von Hirt-Line®.

Dem verpflichten wir uns durch die eigene, flexible Fertigung und einem hohen Qualitätsanspruch. Ob Serienfertigung von Standardprodukten oder Einzelanfertigung von Sonderlösungen - wir sind gerne für Sie da!

Fully customizable and adjustable cooling

Plastic joint hoses are very flexible coolant lines, but offer only limited operational reliability. Standard coolant lines are often adjusted by vibrations or chips and the coolant does not reach the point where it is useful. Machine downtime and tooling damage are expensive and can be avoided. Our vendor-independent Hirt-Line® coolant pipe system for turning, milling and grinding machines boost your productivity.

MADE IN SWITZERLAND is the quality guarantee of Hirt-Line®.

We pledge ourselves to that by means of our flexible production and high quality demands. Batch production of standard products or individual production of customized solutions - with pleasure we are there for you!

SONDERLÖSUNGEN NACH MASS AUF ANFRAGE ERHÄLTlich!
SPECIAL CUSTOM-MADE SOLUTIONS AVAILABLE ON REQUEST!







Eigenschaften:

- Strahl punktgenau einstell-/ und fixierbar durch Verschraubung
- Resistent gegen hohe Temperaturen, chemischen Substanzen, Späne, Druck und Vibrationen
- Korrosionsbeständiges Material 1.4305
- Verschleißfest
- Hohe Lebensdauer
- Direkt am Werkzeug einsetzbar (AGW-Anschluss)
- Vielseitig kombinierbar
- KSM-Druck über 100 bar
- Durchdachtes und effektives Sortiment
- Anschlusselemente für jede Maschine (Sonderanfertigungen möglich)
- Komplett-Sets für Ihre Maschine (auf Anfrage)

Properties:

- *jet precisely adjustable and fixed by screwing*
- *resistant against heat and chemical substances, chips, pressure and vibration*
- *Corrosion-resistant material 1.4305*
- *wear-resistant*
- *high life span*
- *usable directly on the tool (tool-connector)*
- *versatile combination*
- *pressure resistant over 100 bar*
- *sophisticated and effective assortment*
- *connection elements for each machine (custom-made possible)*
- *assembled sets for your machine (on request)*

HIRT-LINE® GELENKSCHLÄUCHE IN 2 GRÖSSEN:
HIRT-LINE® COOLANT HOSE SYSTEM IN 2 SIZES:

Hirt
LINE

KLEINES SYSTEM: 1/4"
SMALL SYSTEM: 1/4"

Hirt
LINE

GROSSES SYSTEM: 1/2"
BIG SYSTEM: 1/2"

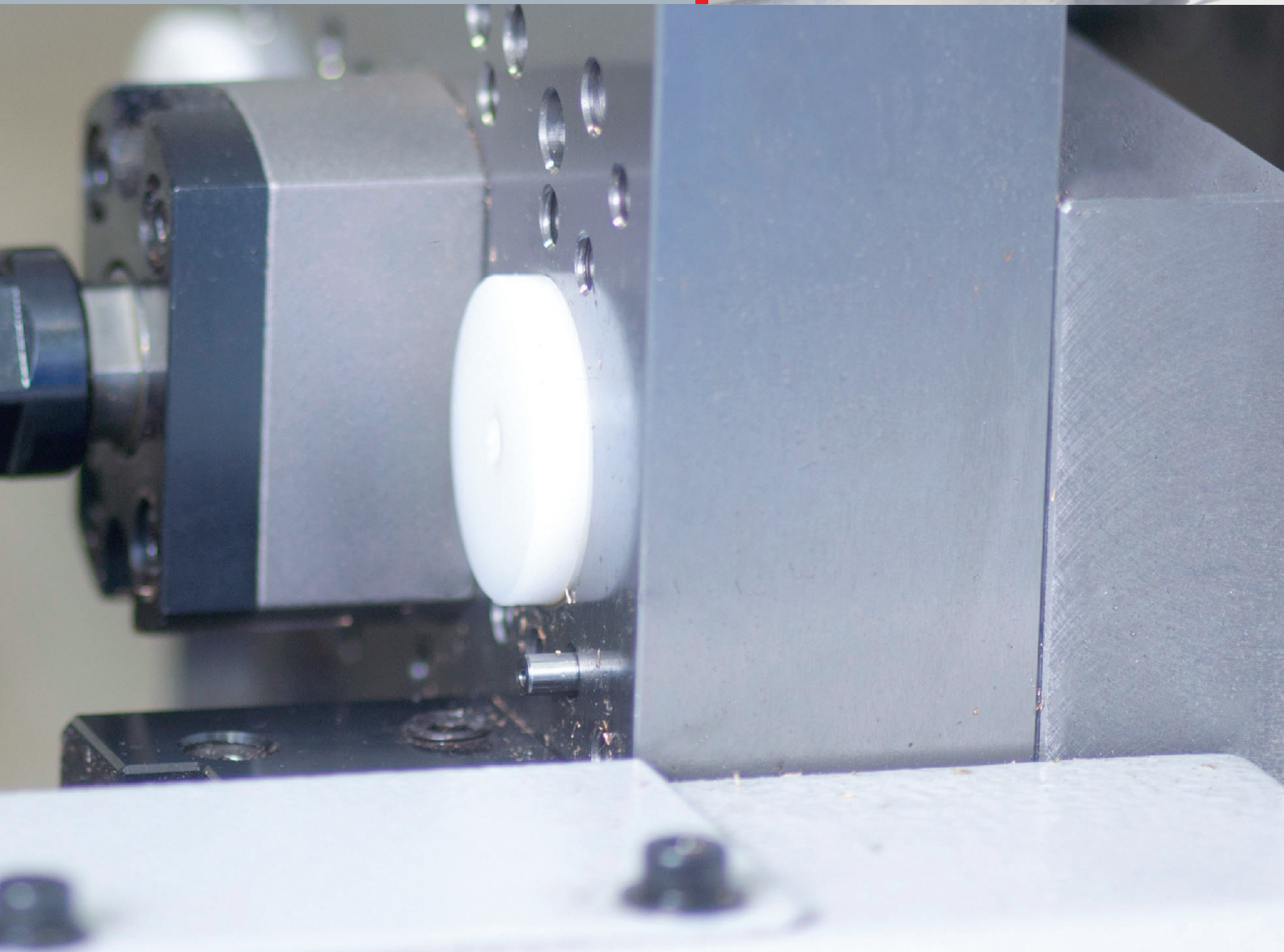

Ein Baukasten, der überzeugt!

Das Hirt-Line® System kann die Basis einer erfolgreichen Produktion sein. Die Basis für das System wiederum sind seine einzelnen Komponenten. Um Kunden die Möglichkeit zu eröffnen, bei der Gestaltung und Umsetzung ihrer Anlagen ganz eigene Wege zu gehen, macht Hirt-Line® alle Komponenten und deren Daten hier einzeln verfügbar. Hirt-Line® hat alle seine Elemente in einem Katalog für schnelle und einfache Bestellung zusammengestellt.

A construction kit, the convinces!

The Hirt-Line® system is the perfect basis for a successful production. And the basis of the system are its individual components. To enable customers to explore their own ways when designing and constructing their systems, Hirt-Line® has compiled a catalog with all of its elements for quick and easy ordering.

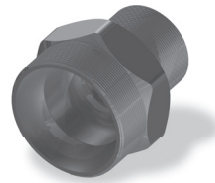

MASCHINENADAPTER
MACHINE ADAPTER

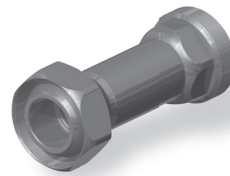

GRUNDELEMENTE
BASIC ELEMENTS

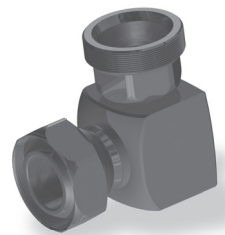

WINKELEMENTE
ELBOWS

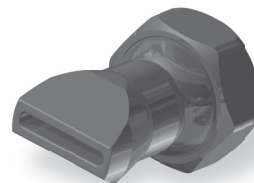

DÜSEN
NOZZLES

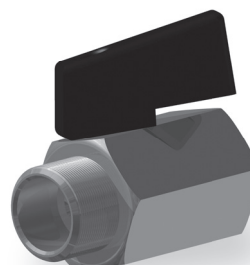

ZUBEHÖR
ACCESSORIES

BEISPIEL:
FRÄSMASCHINE

EXAMPLE:
MILLING MACHINE



PRODUKTÜBERSICHT

PRODUCT OVERVIEW

Hirt-Line[®]

Kleines System 1/4 Zoll
(Durchlass 5,8 mm)

Small System 1/4 Inch
(Outlet 5,8 mm)



Gesamtübersicht / Overview Typ 1 System 1/4"

Maschinenadapter / Machine Adapter

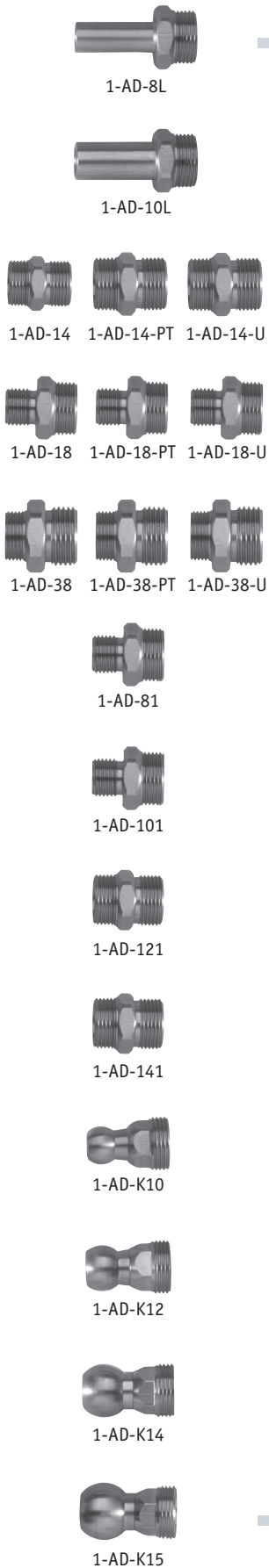

Grundelemente / Basic Elements

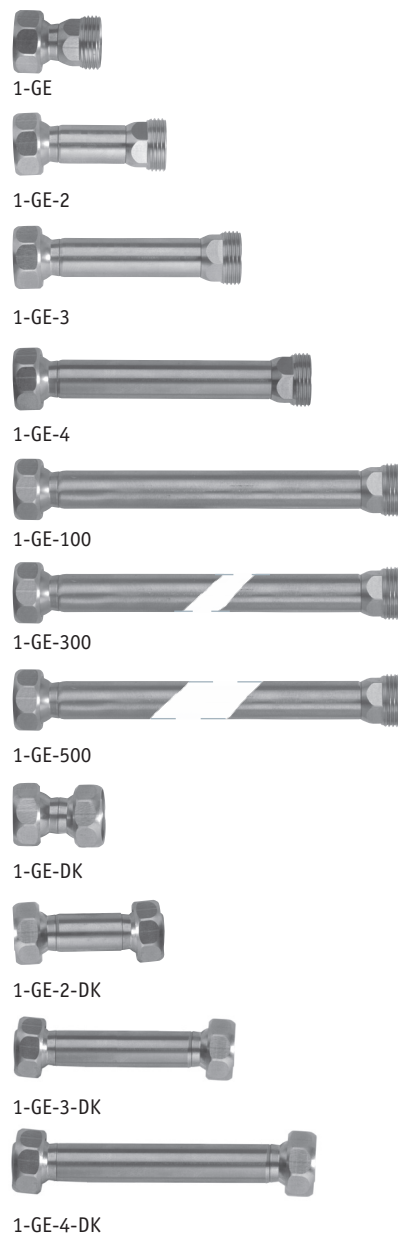

Winklelemente / Elbows



Düsen / Nozzles



Grundelemente / Basic Elements



1-GE

l=21,5 mm effektiv l=18,7 mm
l=21,5 mm effective l=18,7 mm

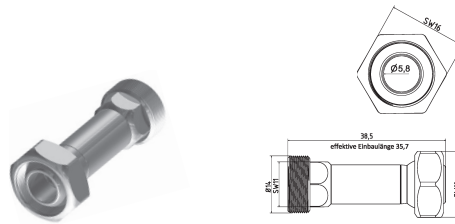

1-GE-2

l=38,5 mm effektiv l=35,7 mm
l=38,5 mm effective l=35,7 mm

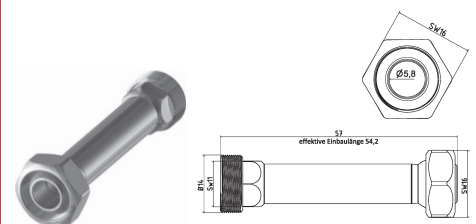

1-GE-3

l=57 mm effektiv l=54,2 mm
l=57 mm effective l=54,2 mm

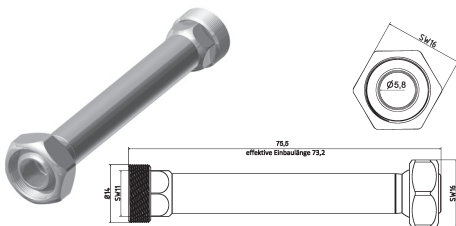

1-GE-4

l=75,5 mm effektiv l=73,7 mm
l=75,5 mm effective l=73,7 mm



1-GE-DK

l=22 mm effektiv l=18,7 mm Doppelkugel
l=22 mm effective l=18,7 mm double ball

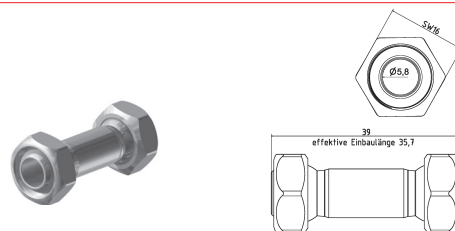

1-GE-2-DK

l=39 mm effektiv l=35,7 mm Doppelkugel
l=39 mm effective l=35,7 mm double ball

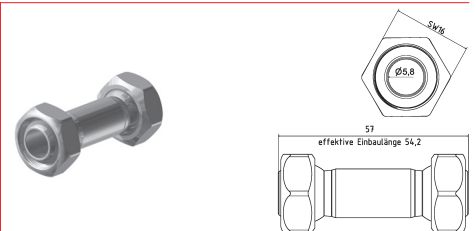

1-GE-3-DK

l=57 mm effektiv l=54,2 mm Doppelkugel
l=57 mm effective l=54,2 mm double ball

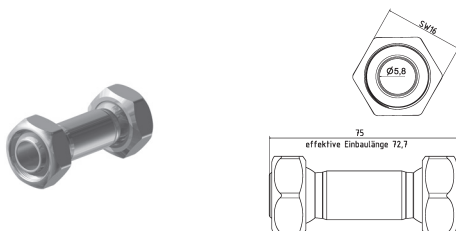

1-GE-4-DK

l=75 mm effektiv l=72,7 mm Doppelkugel
l=75 mm effective l=72,7 mm double ball

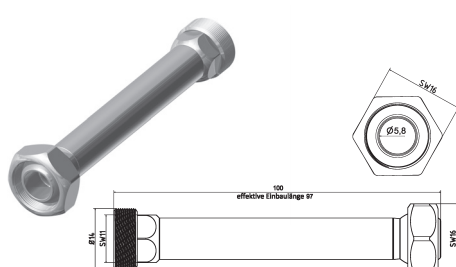

1-GE-100

l=100 mm effektiv l=97 mm
l=100 mm effective l=97 mm

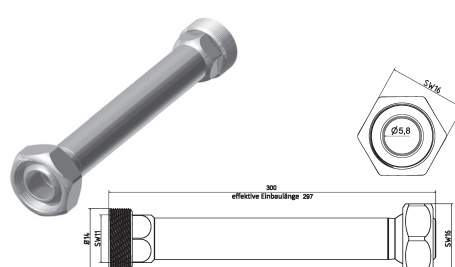

1-GE-300

l=300 mm effektiv l=297 mm
l=300 mm effective l=297 mm

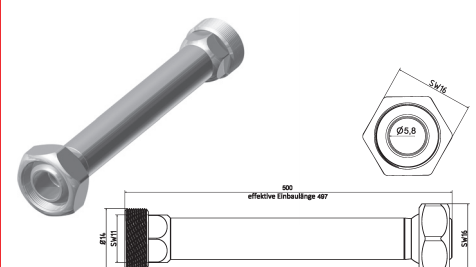

1-GE-500

l=500 mm effektiv l=497 mm
l=500 mm effective l=497 mm

Maschinenadapter / Machine Adapter

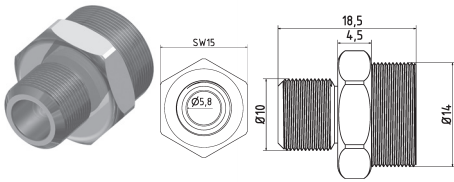

1-AD-18

Adapterstück G 1/8"

adaptor piece thread 1/8"

1-AD-18-PT

Adapterstück G 1/8" PT (Withworth-Gewinde)

adaptor piece thread 1/8" PT (NPT thread)

1-AD-18-U

Adapterstück G 1/8" U
(Gewinde unterschritten)

*adaptor piece thread 1/8" U
(Undercut thread)*

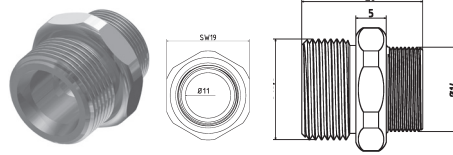

1-AD-38

Adapterstück G 3/8"

adaptor piece thread 3/8"

1-AD-38-PT

Adapterstück G 3/8" PT (Withworth-Gewinde)

adaptor piece thread 3/8" PT (NPT thread)

1-AD-38-U

Adapterstück G 3/8" U
(Gewinde unterschritten)

*adaptor piece thread 3/8" U
(Undercut thread)*

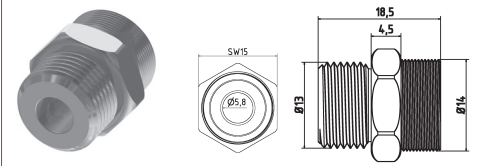

1-AD-14

Adapterstück G 1/4"

adaptor piece thread 1/4"

1-AD-14-PT

Adapterstück G 1/4" PT (Withworth-Gewinde)

adaptor piece thread 1/4" PT (NPT thread)

1-AD-14-U

Adapterstück G 1/4" U
(Gewinde unterschritten)

*adaptor piece thread 1/4" U
(Undercut thread)*

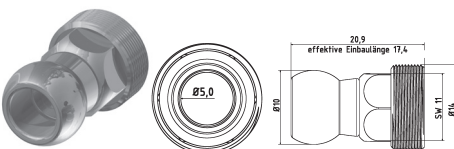

1-AD-K10

Adapterstück Kugel Ø 10 (z.B. Traub)

adaptor piece ball Ø 10 mm (e.g. Traub)

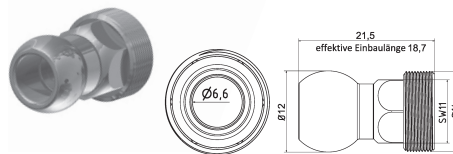

1-AD-K12

Adapterstück Kugel Ø 12 (z.B. MORI SEIKI)

adaptor piece ball Ø 12 mm (e.g. MORI SEIKI)

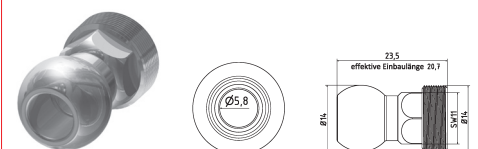

1-AD-K14

Adapterstück Kugel Ø 14 (z.B. Wenk)

adaptor piece ball Ø 14 mm (e.g. Wenk)

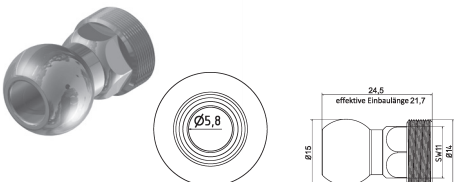

1-AD-K15

Adapterstück Kugel Ø 15 (z.B. Okuma)

adaptor piece ball Ø 15 mm (e.g. Okuma)

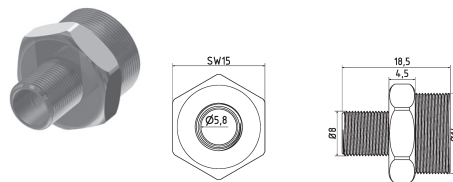

1-AD-81

Adapterstück M8 x 1

adaptor piece M8 x 1 metric thread

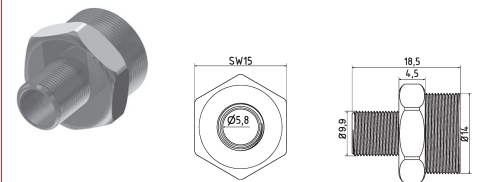

1-AD-101

Adapterstück M10 x 1

adaptor piece M10 x 1 metric thread

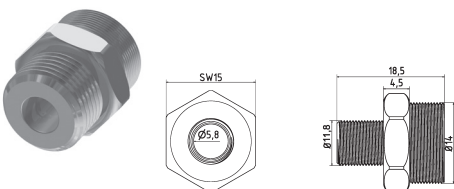

1-AD-121

Adapterstück M 12 x 1

adaptor piece M 12 x 1 metric thread

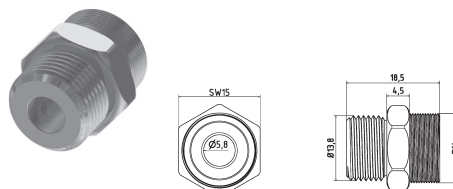

1-AD-141

Adapterstück M 14 x 1

adaptor piece M 14 x 1 metric thread

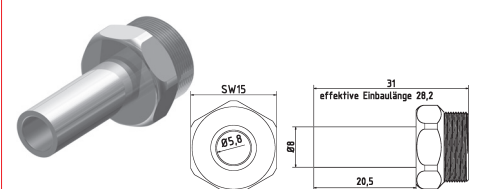

1-AD-8L

Adapterstück zu Hydraulik-Verschraubung 8 L

adaptor piece to hydraulic system 8 L

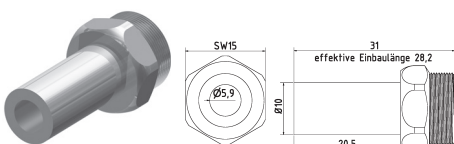

1-AD-10L

Adapterstück zu Hydraulik-Verschraubung 10 L

adaptor piece to hydraulic system 10 L

Winkelemente / Elbows

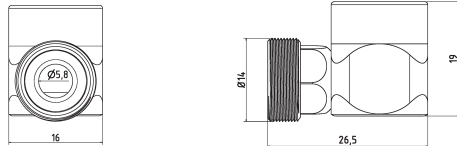

1-WV-1

Winkerverschraubung
elbow piece fixed

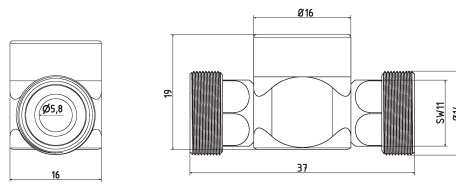
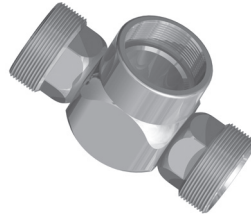

1-WV-2

T-Stück
T-piece fixed

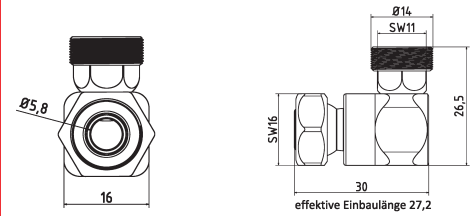
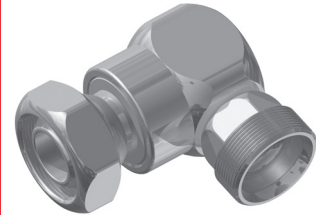

1-WV-1K

Winkerverschraubung mit Kugelstück
elbow piece moveable

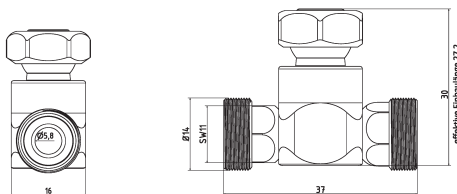
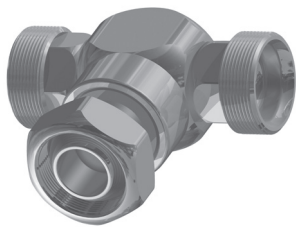

1-WV-2K

T-Stück mit Kugelstück
T-piece moveable

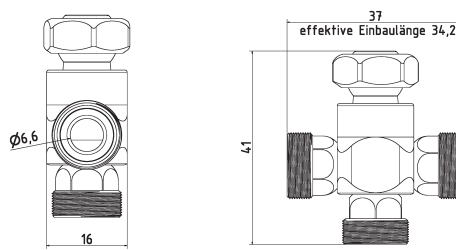
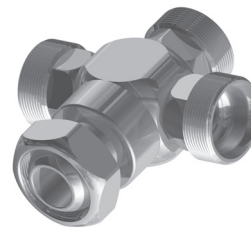

1-WV-3K

Kreuz-Stück mit Kugelstück
cross piece moveable

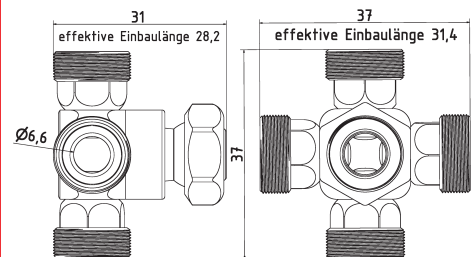

1-WV-4K

Stern-Stück mit Kugelstück
star piece moveable

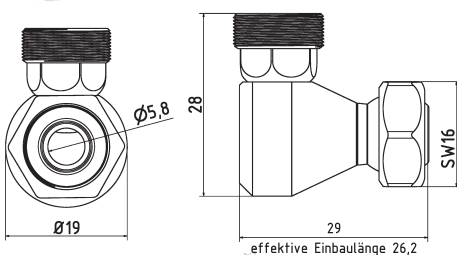

1-WI

Winkelstück für Leitungen
corner piece for pipelines

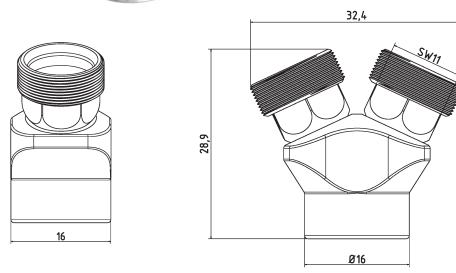

1-YV

Y-Stück 50°
Y-piece 50°

Düsen / Nozzles

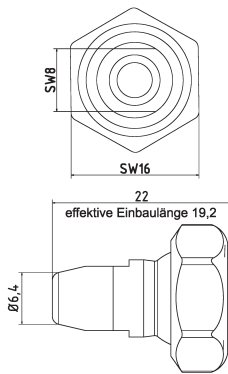
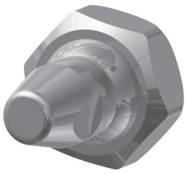

1-DU-0

Düse ohne Bohrung
nozzle straight without drilling

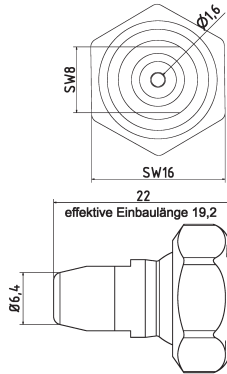
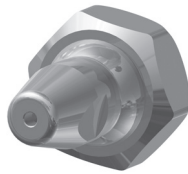

1-DU-16

Düse gerade Bohrung $\varnothing 1,6$ mm
nozzle straight $\varnothing 1,6$ mm

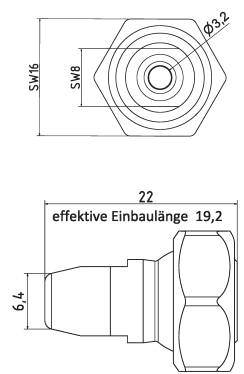

1-DU-32

Düse gerade Bohrung $\varnothing 3,2$ mm
nozzle straight $\varnothing 3,2$ mm

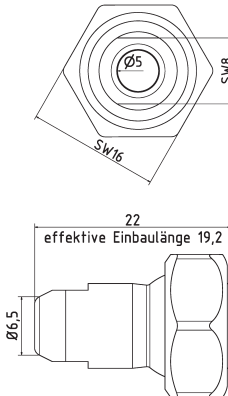
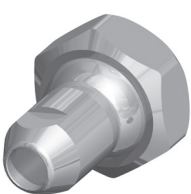

1-DU-50

Düse gerade Bohrung $\varnothing 5,0$ mm
nozzle straight $\varnothing 5,0$ mm

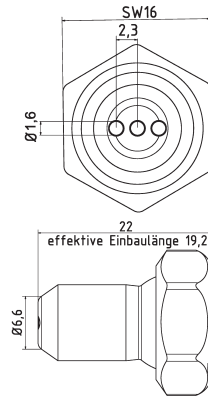
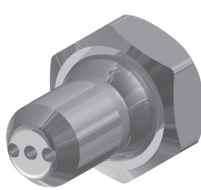

1-DU-3-16

Düse gerade Bohrung $3 \times \varnothing 1,6$ mm
nozzle straight $3 \times \varnothing 1,6$ mm

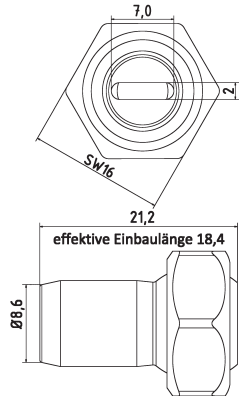
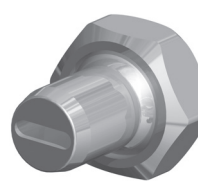

1-DU-72

Düse mit Schlitz $7 \times 2,0$ mm
nozzle straight with slit $7 \times 2,0$ mm

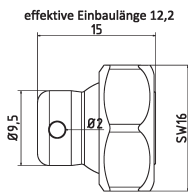
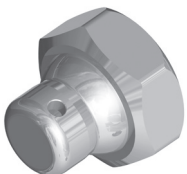

1-DU-90-1

Düse 90° Bohrung $1 \times \varnothing 2$ mm
nozzle 90° drill hole $1 \times \varnothing 2$ mm

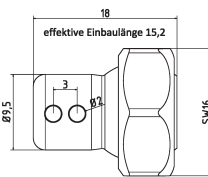
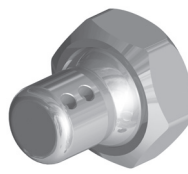

1-DU-90-2

Düse 90° Bohrung $2 \times \varnothing 2$ mm
nozzle 90° drill hole $2 \times \varnothing 2$ mm

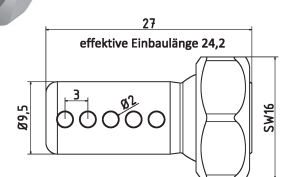
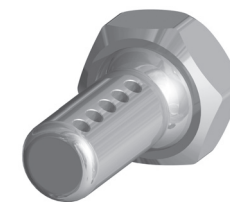

1-DU-90-5

Düse 90° Bohrung $5 \times \varnothing 2$ mm
nozzle 90° drill hole $5 \times \varnothing 2$ mm

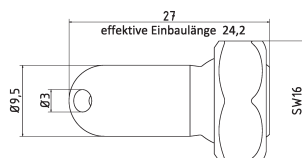
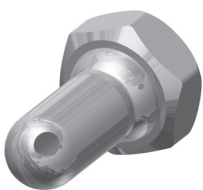

1-DU-30

Düse 30° Bohrung $\varnothing 3$ mm
nozzle 30° drill hole $\varnothing 3$ mm

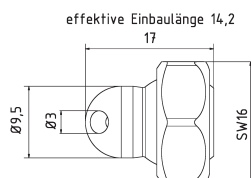
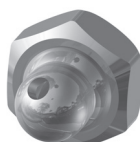

1-DU-30-EK

Düse 30° Bohrung $\varnothing 3$ mm extra kurz
nozzle 30° drill hole $\varnothing 3$ mm extra short

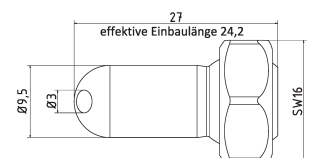
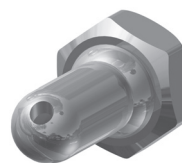

1-DU-60

Düse 60° Bohrung $\varnothing 3$ mm
nozzle 60° drill hole $\varnothing 3$ mm

Düsen / Nozzles

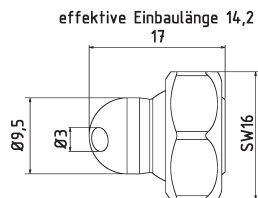
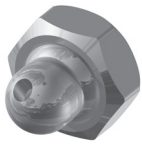

1-DU-60-EK

Düse 60° Bohrung $\varnothing 3$ mm extra kurz
nozzle 60° drill hole $\varnothing 3$ mm extra short

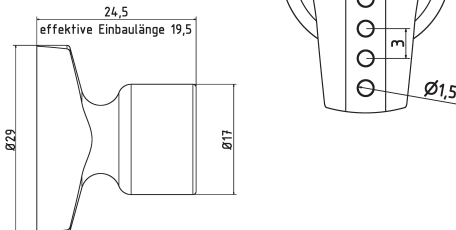
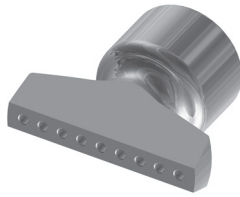

1-DU-BL

Düse Breit mit Bohrungen $9 \times \varnothing 1,5$ mm
nozzle broadly with drillings $9 \times \varnothing 1,5$ mm

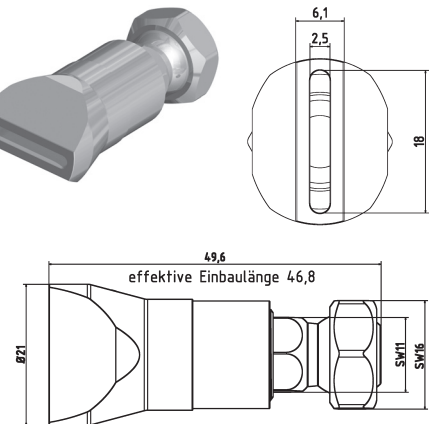
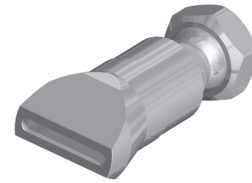

1-DU-SL-GS

Flachdüse Breit mit Schlitz $18 \times 2,5$ mm
gerader Strahl
flat nozzle broadly with slit $18 \times 2,5$ mm
straight jet

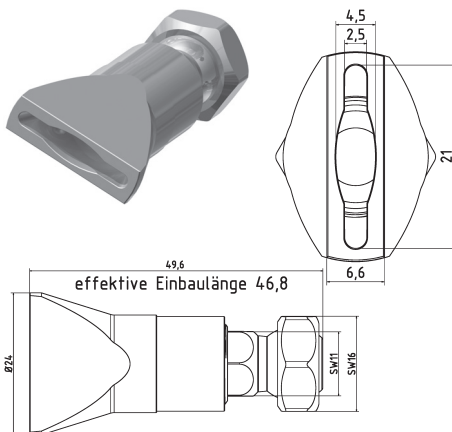
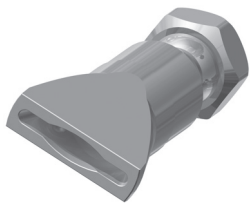

1-DU-SL-SS

Flachdüse Breit mit Schlitz $21 \times 2,5$ mm
Streustrahl
flat nozzle broadly with slit $21 \times 2,5$ mm
scattered beam

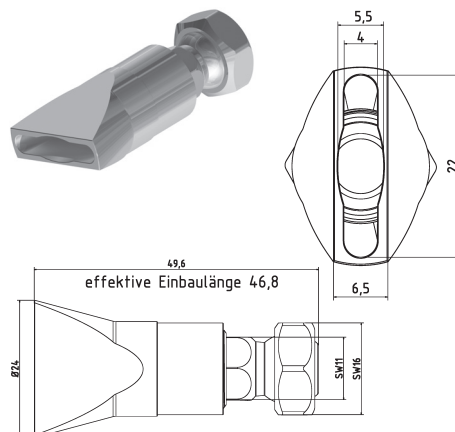
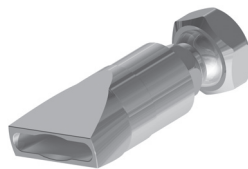

1-DU-SL-25

Flachdüse Breit mit Schlitz $22 \times 4,0$ mm
Streustrahl zum Schwemmen
flat nozzle broadly with slit $22 \times 4,0$ mm
scattered beam

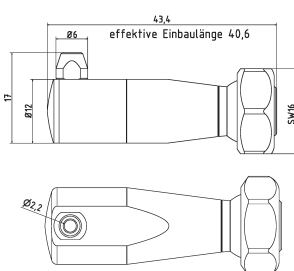
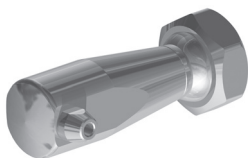

1-HA-DU

Halterung Düse klein $l=40$ inkl. 3 Düsen
small nozzle holder $l=40$ incl. 3 nozzles

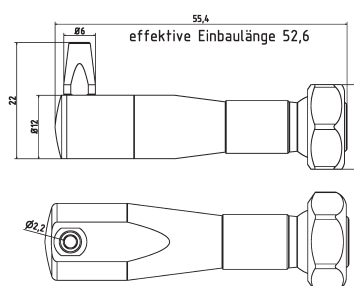
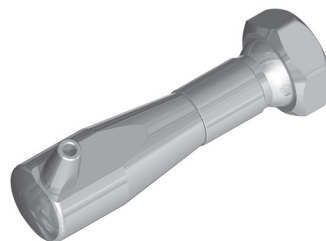

1-HA-DU-2

Halterung Düse klein $l=55$ inkl. 3 Düsen
small nozzle holder $l=55$ incl. 3 nozzles

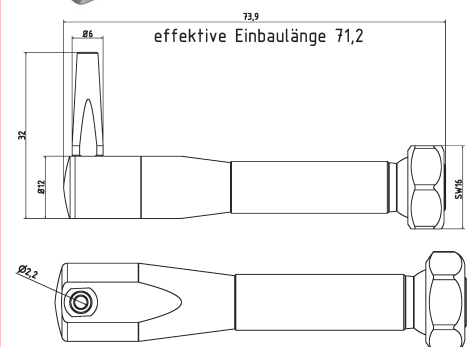
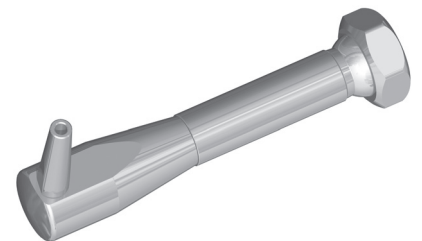

1-HA-DU-3

Halterung Düse klein $l=70$ inkl. 3 Düsen
small nozzle holder $l=70$ incl. 3 nozzles

Kunststoff-Düsen / Plastic Nozzles

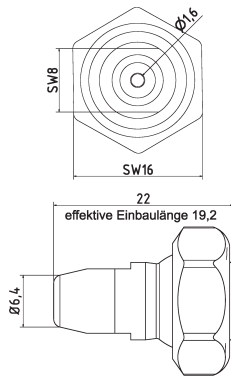
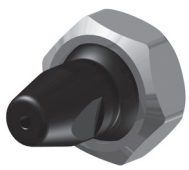

KU-1-DU-16

Kunststoff-Düse gerade Bohrung Ø 1,6 mm
plastic nozzle straight Ø 1,6 mm

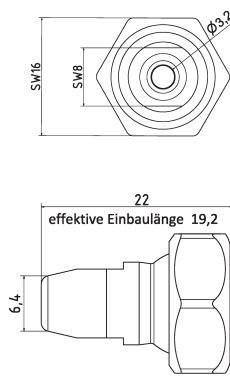
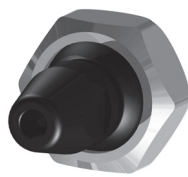

KU-1-DU-32

Kunststoff-Düse gerade Bohrung Ø 3,2 mm
plastic nozzle straight Ø 3,2 mm

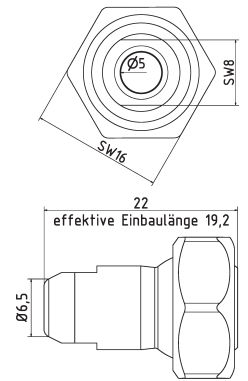
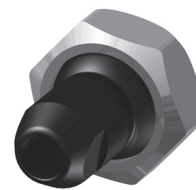

KU-1-DU-50

Kunststoff-Düse gerade Bohrung Ø 5,0 mm
plastic nozzle straight Ø 5,0 mm

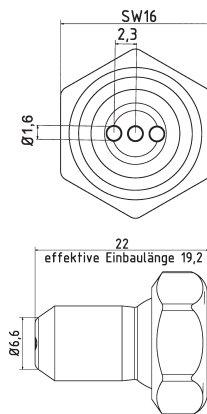
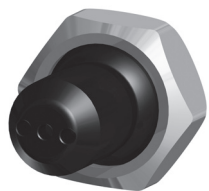

KU-1-DU-3-16

Kunststoff-Düse gerade Bohrung 3 x Ø 1,6 mm
plastic nozzle straight 3 x Ø 1,6 mm

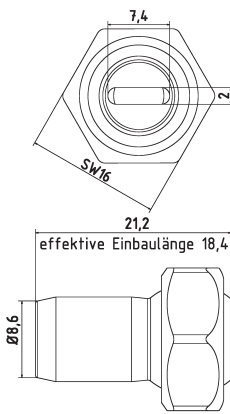
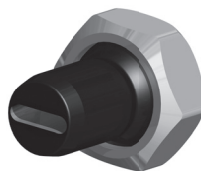

KU-1-DU-72

Kunststoff-Düse mit Schlitz 7 x 2,0 mm
plastic nozzle straight with slit 7 x 2,0 mm

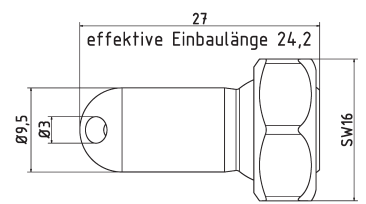
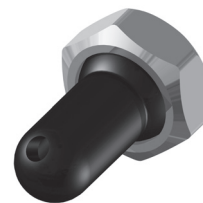

KU-1-DU-30

Kunststoff-Düse 30° Bohrung Ø 3 mm
plastic nozzle 30° drill hole Ø 3 mm

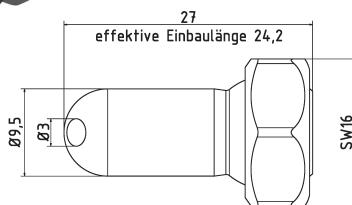
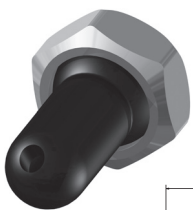

KU-1-DU-60

Kunststoff-Düse 60° Bohrung Ø 3 mm
plastic nozzle 60° drill hole Ø 3 mm

Zubehör / Accessories

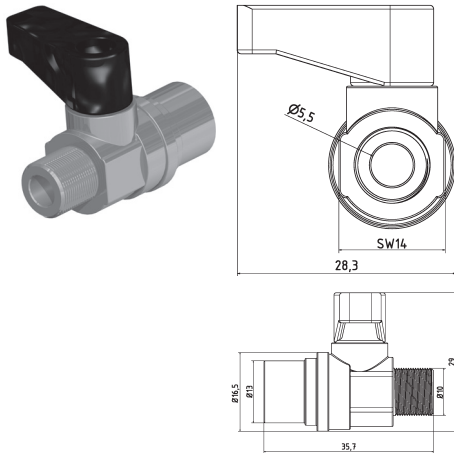

KH-18
Mini-Kugelhahn G1/8" Messing Verchromt
mini ball valve thread 1/8" brass chrome-plated

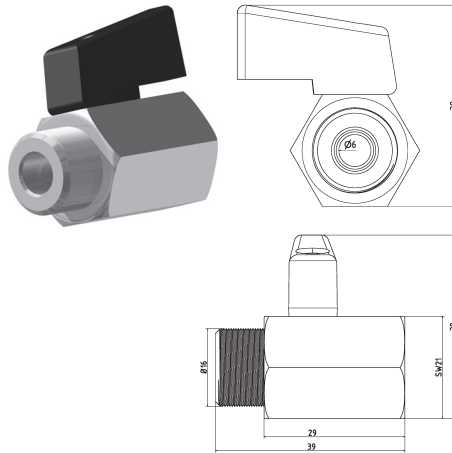

KH-14
Mini-Kugelhahn G1/4" Messing Verchromt
mini ball valve thread 1/4" brass chrome-plated

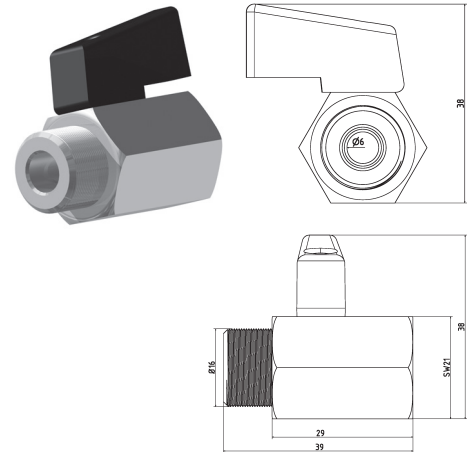

KH-14-SS
Mini-Kugelhahn G1/4" Edelstahl
mini ball valve thread 1/4" stainless steel



SW-11
Schlüssel aus Stahl SW11
open end wrench SW11



SW-16
Schlüssel aus Stahl SW16
open end wrench SW16

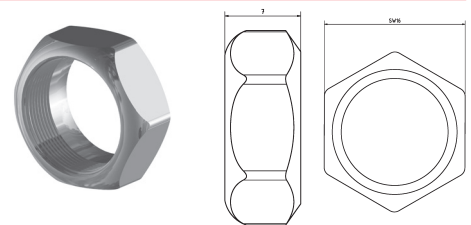

1-MU
Mutter Standard
screw nut (default)

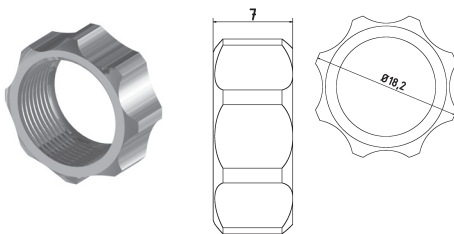

1-MU-HA
Mutter für Handverstellung
screw nut (hand feed)

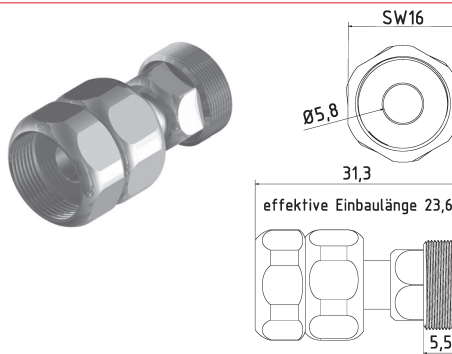

1-FP
Zwischenelement mit fester Position
(Schnellkupplung)
*Intermediate element with fixed position
(quick coupling)*

Grundset / Basic Set

1-GS
Grundset Typ1 1/4" System bestehend aus:
basic set Typ1 1/4" system l=220 mm
6 x 1-GE, 1 x 1-GE-2, 1 x 1-GE-3, 1 x 1-AD-18,
1 x 1-AD-14, 1 x 1-DU-16, 1 x 1-DU-32

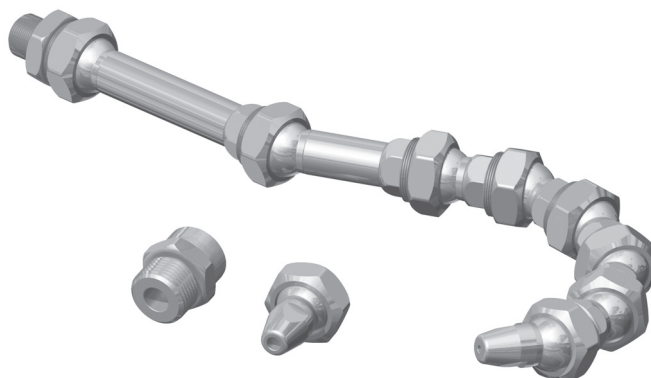

Biegeradius

Der Durchlass-Querschnitt bleibt in jeder beliebigen Position konstant. Es entstehen keine Knicke oder Brüche wie bei Metallrohren.

Bending radius

*The passage cross-section is constant at any position.
There are no kinks or breaks as with metal pipes.*

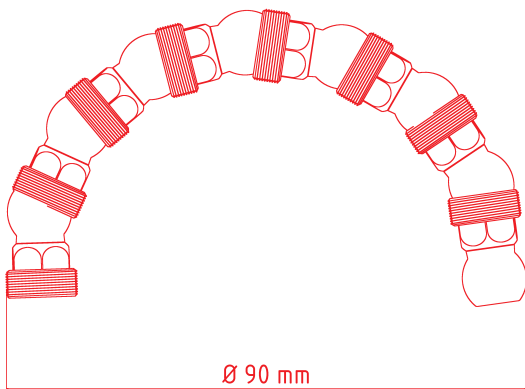

Typ 1: 1/4"

Leitung Innendurchmesser Pipe inner diameter

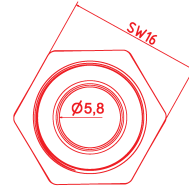

Kleines System
Small System

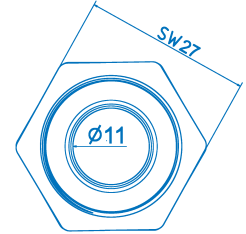

Großes System
Big System

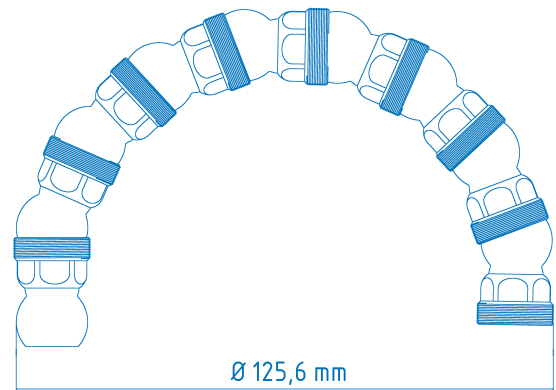

Typ 2: 1/2"

BEISPIEL:
SCHLEIFMASCHINE
EXAMPLE:
GRINDING MACHINE

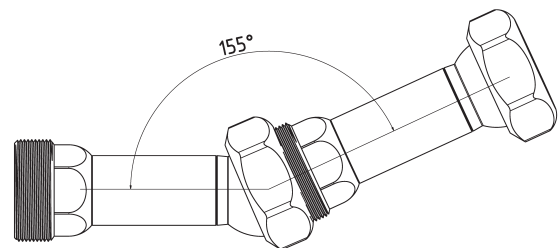
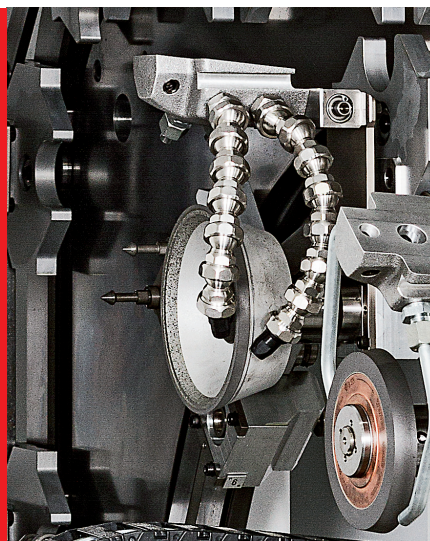

Maximaler Einstellwinkel 155°
Maximum adjustment angle 155°

PRODUKTÜBERSICHT

PRODUCT OVERVIEW

Hirt-Line[®]

Großes System 1/2 Zoll
(Durchlass 11 mm)

Big System 1/2 Inch
(Outlet 11 mm)



Gesamtübersicht / Overview Typ 2 System 1/2"

Maschinenadapter / Machine Adapter



2-AD-12



2-AD-12-PT



2-AD-12-U



2-AD-34



2-AD-34-PT



2-AD-34-U



2-AD-38



2-AD-38-PT



2-AD-38-U

Grundelemente / Basic Elements



2-GE



2-GE-2



2-GE-3

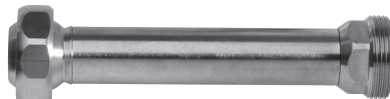

2-GE-100

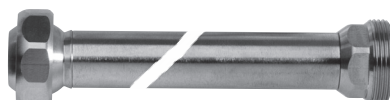

2-GE-300

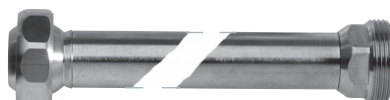

2-GE-500

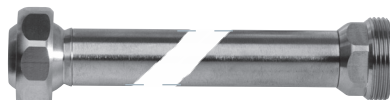

2-GE-1000



2-GE-DK

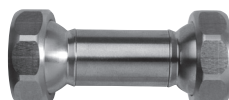

2-GE-2-DK



2-GE-3-DK



2-GE-3-DKS

Winklelemente / Elbows



2-WI



2-WV-1K



2-WV-2K



2-WV-3K



2-WV-4K



2-YV

Düsen / Nozzles



2-DU-10



2-DU-12



2-DU-65



2-DU-SL-25



2-DU-SL-25-GS



2-DU-SL-25-SS

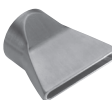

2-DU-SL-50



2-DU-SL-50-GS



2-DU-SL-65-GS



2-DU-SL-76-GS



KU-2-DU-10



KU-2-DU-12



KU-2-DU-65

Grundelemente / Basic Elements

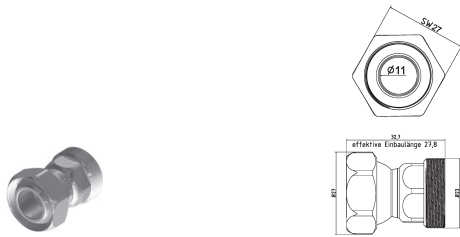

2-GE

$l = 32,7$ mm effektiv $l = 27,8$ mm

$l = 32,7$ mm effective $l = 27,8$ mm

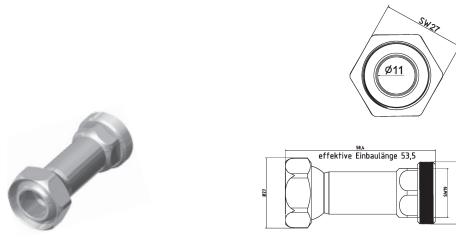

2-GE-2

$l = 58,4$ mm effektiv $l = 53,5$ mm

$l = 58,4$ mm effective $l = 53,5$ mm

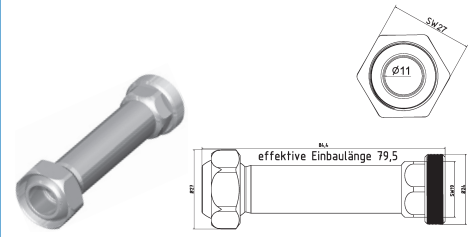

2-GE-3

$l = 84,4$ mm effektiv $l = 79,5$ mm

$l = 84,4$ mm effective $l = 79,5$ mm

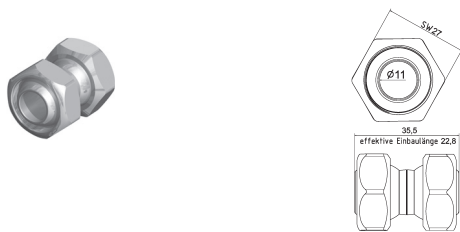

2-GE-DK

$l = 35,5$ mm effektiv $l = 22,8$ mm Doppelkugel

$l = 35,5$ mm effective $l = 22,8$ mm double ball

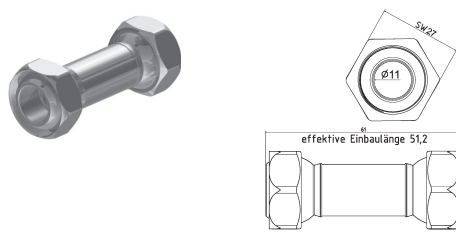

2-GE-2-DK

$l = 61$ mm effektiv $l = 51,2$ mm Doppelkugel

$l = 61$ mm effective $l = 51,2$ mm double ball

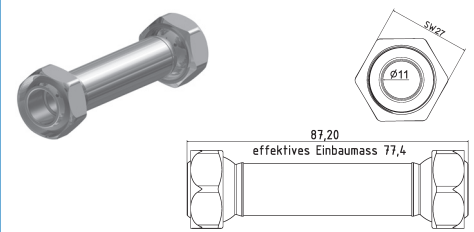

2-GE-3-DK

$l = 87,2$ mm effektiv $l = 77,4$ mm Doppelkugel

$l = 87,2$ mm effective $l = 77,4$ mm double ball

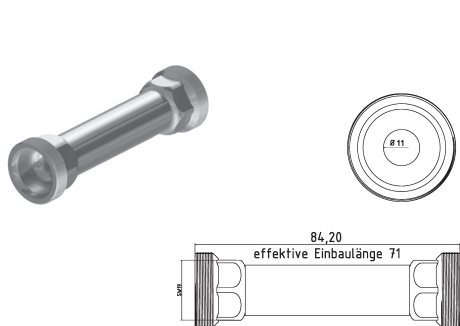

2-GE-3-DKS

$l = 84,2$ effektiv $l = 71$ mm Doppelkalottenstück

$l = 84,2$ effective $l = 71$ mm double cap piece

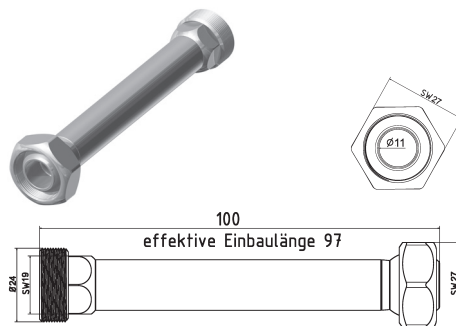

2-GE-100

$l = 100$ mm effektiv $l = 97$ mm

$l = 100$ mm effective $l = 97$ mm

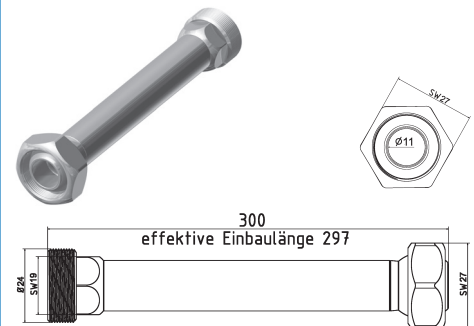

2-GE-300

$l = 300$ mm effektiv $l = 297$ mm

$l = 300$ mm effective $l = 297$ mm

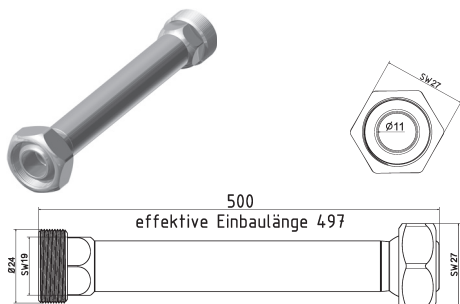

2-GE-500

$l = 500$ mm effektiv $l = 497$ mm

$l = 500$ mm effective $l = 497$ mm

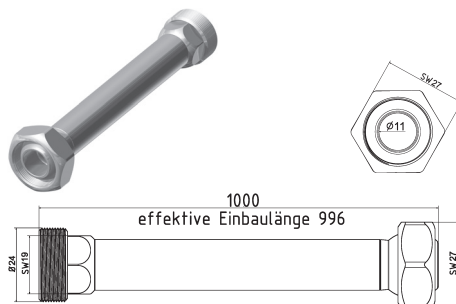

2-GE-1000

$l = 1000$ mm effektiv $l = 996$ mm

$l = 1000$ mm effective $l = 996$ mm

Maschinenadapter / Machine Adapter

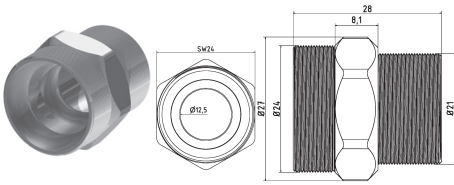

2-AD-12

Adapterstück G 1/2"
adaptor piece thread 1/2"

2-AD-12-PT

Adapterstück G 1/2" PT (Withworth-Gewinde)
adaptor piece thread 1/2" PT (NPT thread)

2-AD-12-U

Adapterstück G 1/2" U
(Gewinde unterschritten)
adaptor piece thread 1/2" U
(Undercut thread)

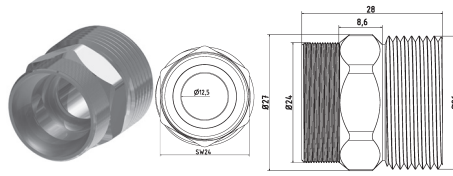

2-AD-34

Adapterstück G 3/4"
adaptor piece thread 3/4"

2-AD-34-PT

Adapterstück G 3/4" PT (Withworth-Gewinde)
adaptor piece thread 3/4" PT (NPT thread)

2-AD-34-U

Adapterstück G 3/4" U
(Gewinde unterschritten)
adaptor piece thread 3/4" U
(Undercut thread)

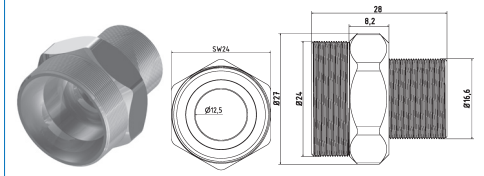

2-AD-38

Adapterstück G 3/8"
adaptor piece thread 3/8"

2-AD-38-PT

Adapterstück G 3/8" PT (Withworth-Gewinde)
adaptor piece thread 3/8" PT (NPT thread)

2-AD-38-U

Adapterstück G 3/8" U
(Gewinde unterschritten)
adaptor piece thread 3/8" U
(Undercut thread)

Winkelelemente / Elbows

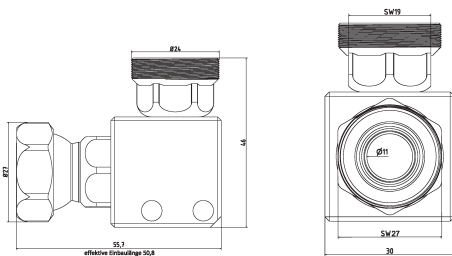
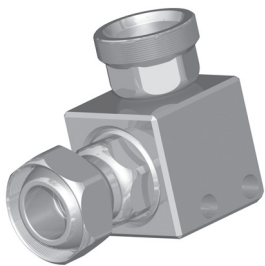

2-WI

Winkelstück für Leitungen mit 2 Bohrungen
corner piece for pipelines with 2 bore hole

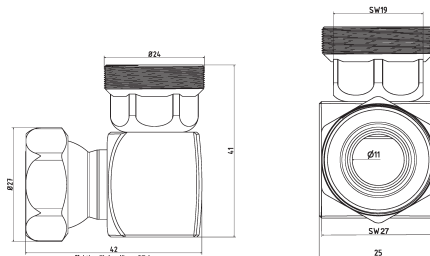
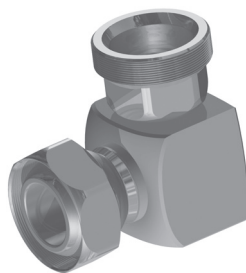

2-WV-1K

Winkelstück
elbow piece

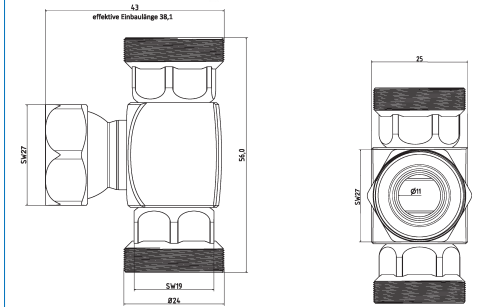
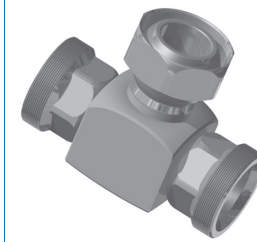

2-WV-2K

T-Stück
T-piece

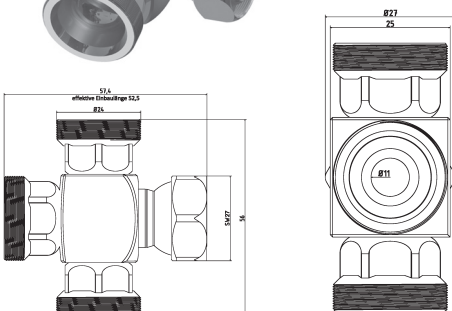
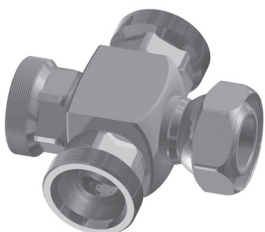

2-WV-3K

Kreuz-Stück
cross piece

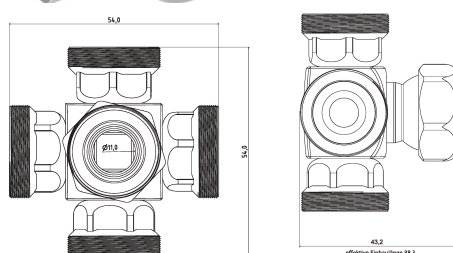

2-WV-4K

Stern-Stück
star piece

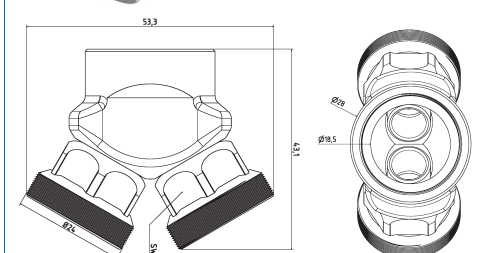
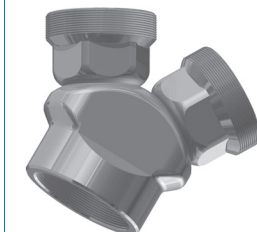

2-YV

Y-Stück 50°
Y-piece 50°

Düsen / Nozzles

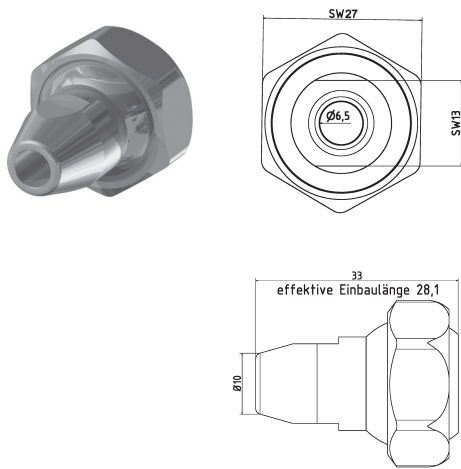

2-DU-65

Düse gerade Bohrung $\varnothing 6,5$ mm
nozzle straight $\varnothing 6,5$ mm

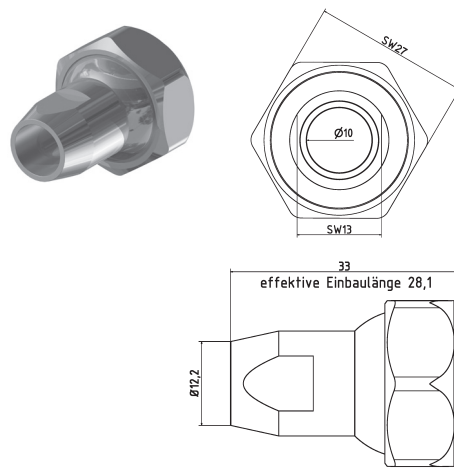

2-DU-10

Düse gerade Bohrung $\varnothing 10$ mm
nozzle straight $\varnothing 10$ mm

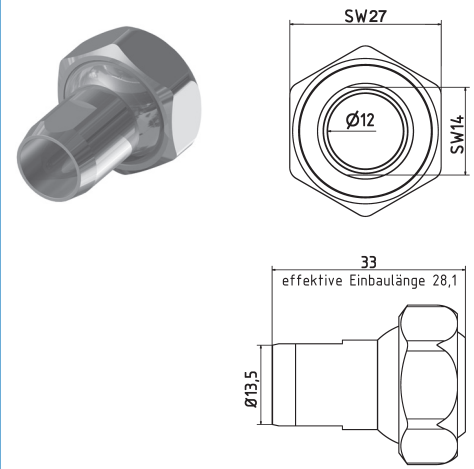

2-DU-12

Düse gerade Bohrung $\varnothing 12$ mm
nozzle straight $\varnothing 12$ mm

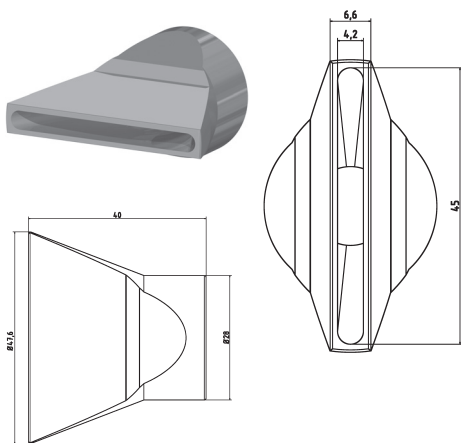

2-DU-SL-50

Flachdüse Schlitzbreite 45x4,2 mm
Streustrahl

flat nozzle broadly with slit 45x4,2 mm
scattered beam

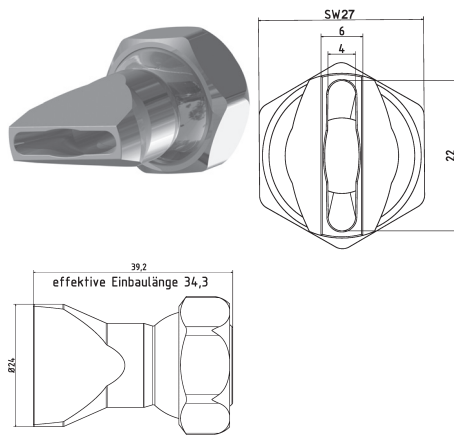

2-DU-SL-25

Flachdüse Schlitzbreite 22x4,0 mm
Streustrahl

flat nozzle broadly with slit 22x4,0 mm
scattered beam

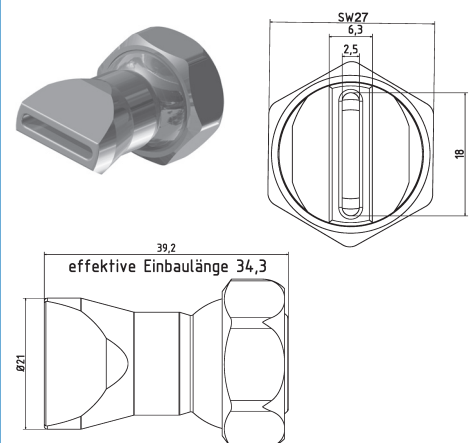

2-DU-SL-25-GS

Flachdüse Schlitzbreite 18x2,5 mm
gerader Strahl

flat nozzle broadly with slit 18x2,5 mm
straight jet

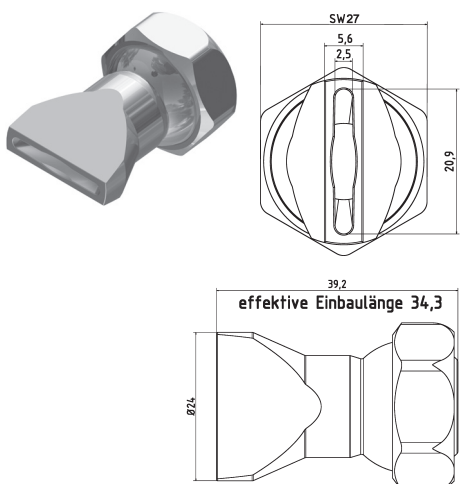

2-DU-SL-25-SS

Flachdüse Schlitzbreite 20x2,5 mm
Streustrahl

flat nozzle broadly with slit 20x2,5 mm
scattered beam

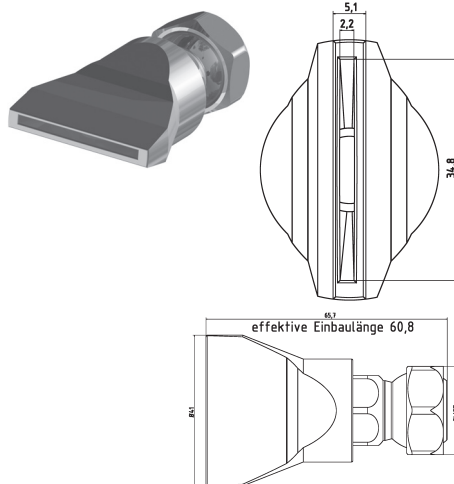

2-DU-SL-50-GS

Flachdüse Schlitzbreite 35x2,2 mm
gerader Strahl

flat nozzle broadly with slit 35x2,2 mm
straight jet

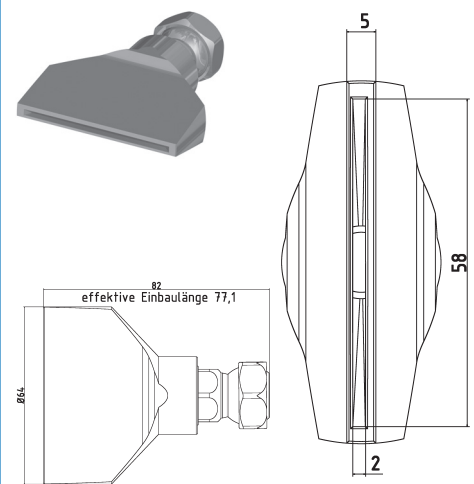

2-DU-SL-65-GS

Flachdüse Schlitzbreite 58x2,0 mm
gerader Strahl

flat nozzle broadly with slit 58x2,0 mm
straight jet

Düsen / Nozzles

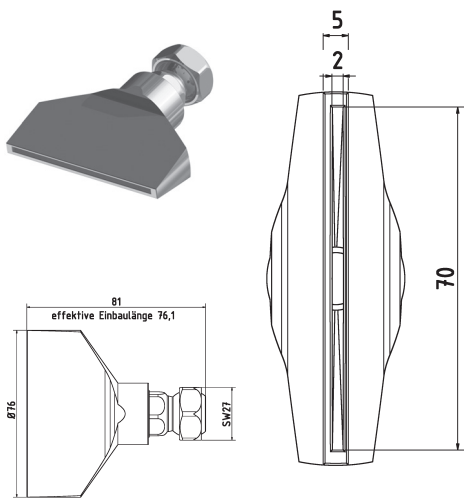

2-DU-SL-76-GS

Flachdüse Schlitzbreite 70x2,0 mm
gerader Strahl

*flat nozzle broadly with slit 70x2,0 mm
straight jet*

Kunststoff-Düsen / Plastic Nozzles

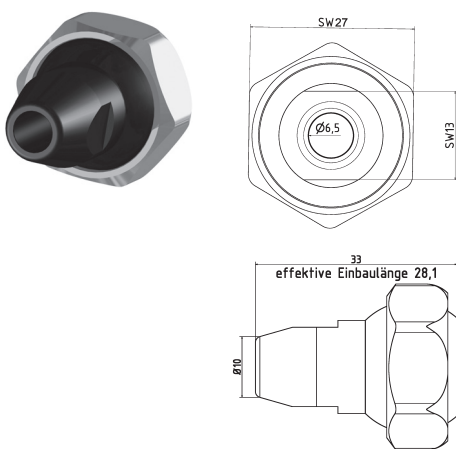

KU-2-DU-65

Kunststoff-Düse gerade Bohrung \varnothing 6,5 mm
plastic nozzle straight \varnothing 6,5 mm

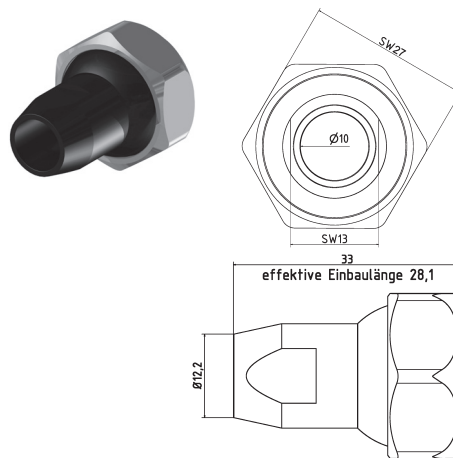

KU-2-DU-10

Kunststoff-Düse gerade Bohrung \varnothing 10 mm
plastic nozzle straight \varnothing 10 mm

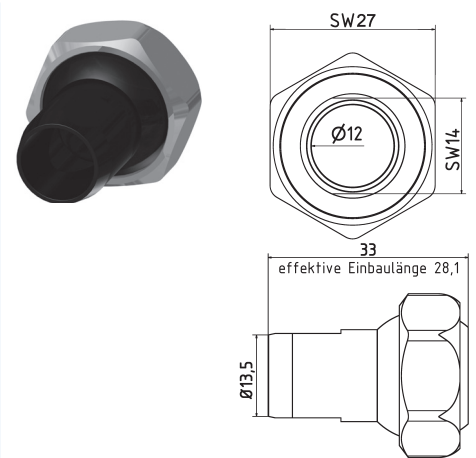

KU-2-DU-12

Kunststoff-Düse gerade Bohrung \varnothing 12 mm
plastic nozzle straight \varnothing 12 mm

Zubehör / Accessories

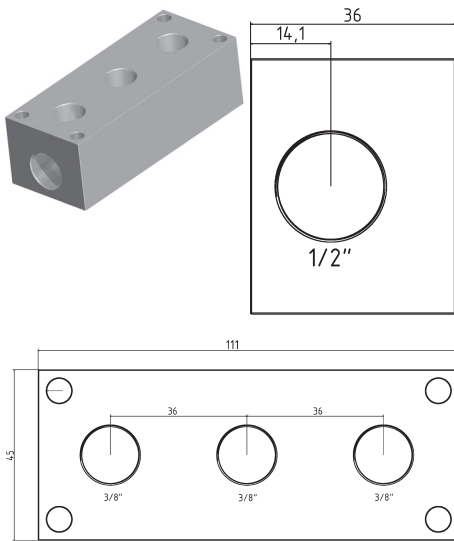

VB-3-38

Verteilerblock Eingang Stirnseite G1/2"
manifold block entrance front end 1/2"

VB-3-38-PT

Verteilerblock Eingang Stirnseite G1/2" PT
manifold block entrance front end 1/2" NPT

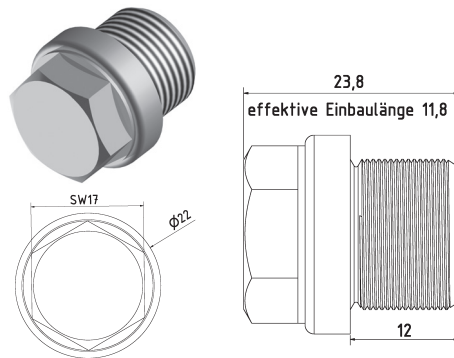

VB-3-38-BS

Blindstopfen G3/8"
blank plug with thread 3/8"

VB-3-38-PT-BS

Blindstopfen mit G3/8" PT Gewinde
blank plug with thread 3/8" NPT

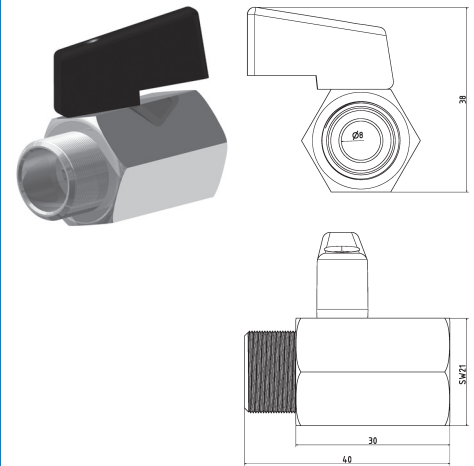

KH-38

Mini-Kugelhahn G3/8" Messing Verchromt
mini ball valve thread 3/8" brass chrome-plated

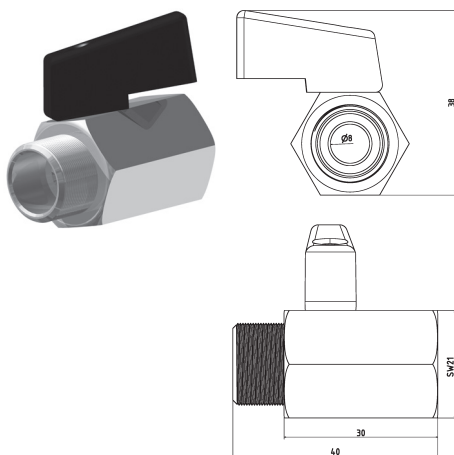

KH-38-SS

Mini-Kugelhahn G3/8" Edelstahl
mini ball valve thread 3/8" stainless steel

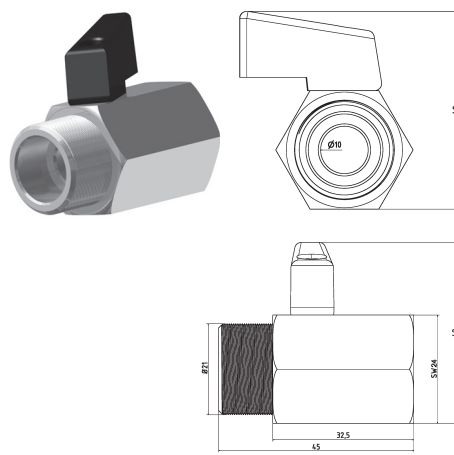

KH-12

Mini-Kugelhahn G1/2" Messing Verchromt
mini ball valve thread 1/2" brass chrome-plated

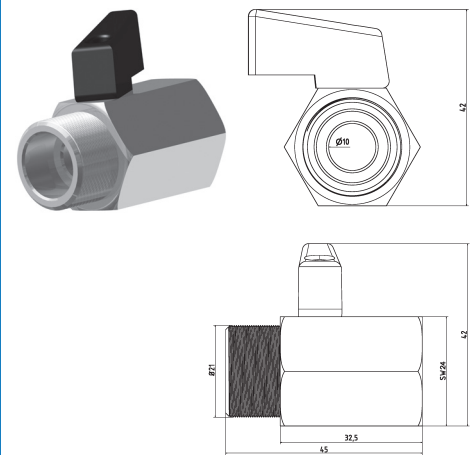

KH-12-SS

Mini-Kugelhahn G1/2" Edelstahl
mini ball valve thread 1/2" stainless steel



SW-19

Schlüssel aus Stahl SW19
open end wrench SW19



SW-27

Schlüssel aus Stahl SW27
open end wrench SW27

Zubehör / Accessories

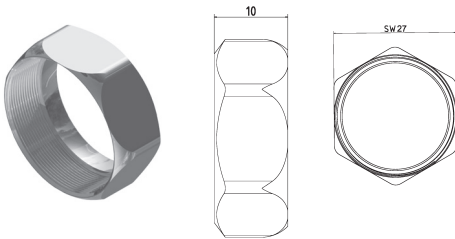

2-MU
Mutter Standard
screw nut (default)

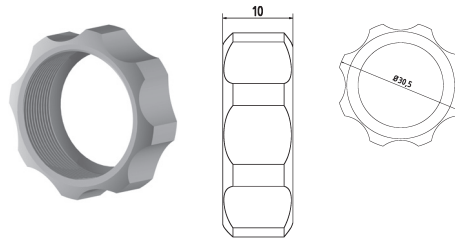

2-MU-HA
Mutter für Handverstellung
screw nut (hand feed)

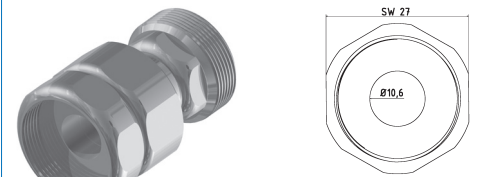

2-FP
Zwischenelement mit fester Position
(Schnellkupplung)
Intermediate element with fixed position
(quick coupling)

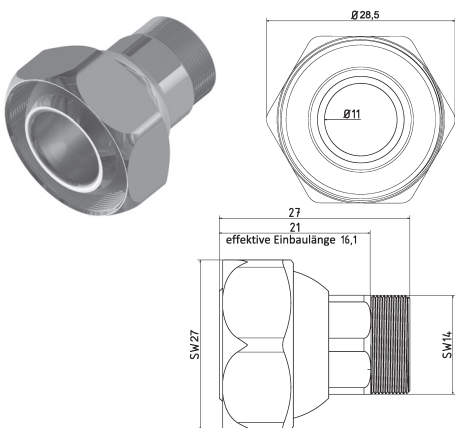
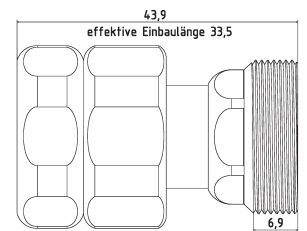

RE-2-1
Reduktion Typ 2 auf Typ 1
reduction Typ 2 to Typ 1

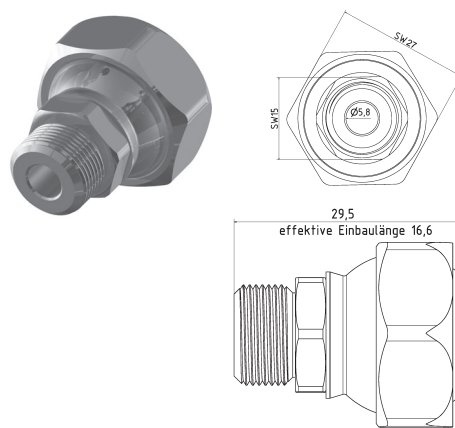

RE-2-G1/4
Reduktion Typ 2 auf G 1/4"
reduction Typ 2 to G 1/4"

Grundset / Basic Set

2-GS
Grundset Typ2 1/2" System bestehend aus:
basic set Typ2 1/2" system $l=240$ mm
5 x 2-GE, 1 x 2-GE-3, 1 x 2-AD-38,
1 x 2-AD-12, 1 x 2-DU-65 1 x 2-DU-10,
1 x SW-19, 1 x SW-27

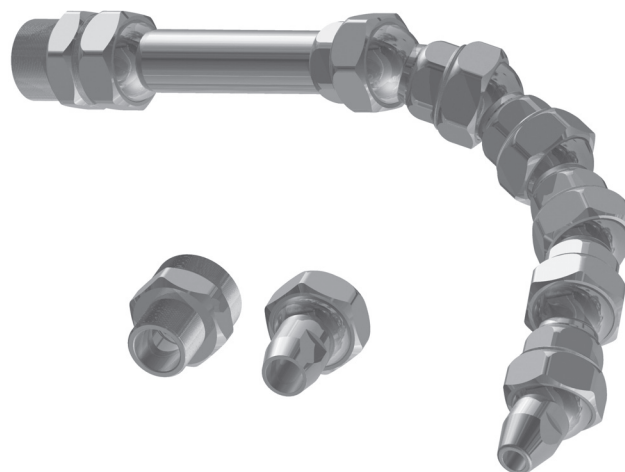

Notiz / Note

Hirt[®]
LINE

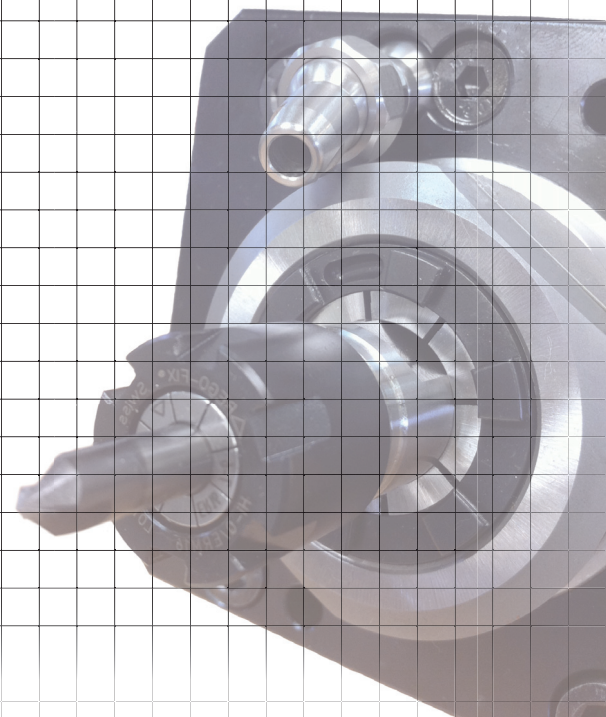



Hirt[®]
LINE

Abbildungen können vom Original abweichen. Änderungen der technischen Daten jederzeit ohne Vorankündigung vorbehalten. Jede Nachbildung des Produktes, gleich ob ganz oder teilweise, sowie der zugehörigen Technologien ist untersagt. Hirt-Line[®] ist ein registrierter Name. Technische Änderungen und Irrtümer vorbehalten. *All illustrations are for reference only. The technical datas are subject to change. A copy of the product, whether in whole or in part, and the related technologies is prohibited. Hirt-Line[®] is a registered name. Technical amendmends and errors may occur.*