



FRAISAGE

FRÄSEN

MILLING

FRESATURA

MARÁS

	SÉLECTION DES FRAISES	96
	FRAISES EN BOUT Z = 1	110
	FRAISES EN BOUT Z = 2	115
	FRAISES EN BOUT Z = 3	127
	FRAISES EN BOUT Z = 4	139
	FRAISES MULTIDENTS	143
	FRAISES TORIQUES	145
	FRAISES HÉMISPHÉRIQUES	151
	FRAISES DIAMANT	160
	FRAISES À CHANFREINER ET À RAYONNER	166
	FRAISES POUR COMPOSITES / KEVLAR®	168
	OUTILS SUR DEMANDE	169
	INFORMATIONS	170
	CONDITIONS DE COUPE	171

SELECTION DES FRAISES

✓ = article de stock

FRAISES EN BOUT Z=1		Z	Page			<input type="checkbox"/> CARBURE	<input type="checkbox"/> TITAIN	<input type="checkbox"/> DIAMANT
DIXI 7561 Ø 2.00 - 12.00		1	110	$L_1 = 2-3 \times \varnothing$		✓		
DIXI 7301 Ø 2.00 - 8.00		1	111	$L_1 = 2.5-4 \times \varnothing$		✓		
DIXI 7302 Ø 3.00 - 12.00		1	111	$L_1 = 2.5-6 \times \varnothing$		✓		
DIXI 7303 Ø 2.00 - 5.00		1	112	$L_1 = 4-6 \times \varnothing$		✓		
DIXI 7060 Ø 0.50 - 6.00		1	113	$L_1 = 1-2 \times \varnothing$		✓		
DIXI 7063 Ø 0.40 - 4.00		1	114	$L_1 = 1-2.5 \times \varnothing$		✓		
FRAISES EN BOUT Z=2		Z	Page			<input type="checkbox"/> CARBURE	<input type="checkbox"/> TITAIN	<input type="checkbox"/> DIAMANT
DIXI 7242 Ø 0.15 - 20.00		2	115	$L_1 = 1.5-5 \times \varnothing$ 	 $D_1 > 6$	✓	✓	
DIXI 7202 Ø 1.50 - 16.00		2	117	$L_1 = 1.5-4 \times \varnothing$		✓	✓	✓
DIXI 7222 Ø 3.00 - 20.00		2	118	$L_1 = 3-10 \times \varnothing$		✓	✓	✓
DIXI 7240 Ø 0.04 - 5.50		2	119	$L_1 = 1 \times \varnothing$		✓	✓	
DIXI 7237 Ø 0.15 - 3.00		2	121	$L_1 = 1 \times \varnothing$ $L_2 = 3 \times \varnothing$		✓	✓	
DIXI 7238 Ø 0.30 - 3.00		2	121	$L_1 = 1 \times \varnothing$ $L_2 = 5 \times \varnothing$		✓	✓	
DIXI 7239 Ø 0.40 - 3.00		2	121	$L_1 = 1 \times \varnothing$ $L_2 = 8 \times \varnothing$		✓	✓	



○ bien ⊙ excellent

Acier + Pb	Acier faibl. allié	Aciers fort. allié	Acier inox aust.	Aciers Fontes 45-65 HRC	Fontes	Super alliages Ni / Co	Titane, alliages de titane	Alliage Cu Argent Or	Alliage Cu difficile	Alu	Graphite	Plastique
------------	--------------------	--------------------	------------------	-------------------------	--------	------------------------	----------------------------	----------------------	----------------------	-----	----------	-----------

								○		⊙		○
												⊙
												⊙
												⊙
○					○			⊙	○	○		○
○					○			⊙	○	○		○

⊙	○	○	○		⊙		⊙	⊙	⊙	○		○
⊙	○		○				○	⊙	○	○	⊙	○
⊙	○		○				○	⊙	○	○	⊙	○
⊙	○	○	○		⊙	○	⊙	⊙	⊙	○		○
⊙	○	○	○		⊙	○	⊙	⊙	⊙	○		○
⊙	○	○	○		⊙	○	⊙	⊙	⊙	○		○
⊙	○	○	○		⊙	○	⊙	⊙	⊙	○		○



SELECTION DES FRAISES

✓ = article de stock

FRAISES EN BOUT Z=2		Z	Page		<input type="checkbox"/> CARBURE	<input checked="" type="checkbox"/> TAIN	<input checked="" type="checkbox"/> CUTINOX	<input checked="" type="checkbox"/> DIAMANT
DIXI 7239-10D Ø 0.50 - 3.00		2	121	L ₁ = 1 x Ø L ₂ = 10 x Ø		✓	✓	
DIXI 7239-12D Ø 0.50 - 1.70		2	121	L ₁ = 1 x Ø L ₂ = 12 x Ø		✓	✓	
DIXI 7239-15D Ø 0.50 - 1.35		2	121	L ₁ = 1 x Ø L ₂ = 15 x Ø		✓	✓	
DIXI 7582 Ø 1.00 - 5.50		2	125	L ₁ = 2 x Ø		✓	✓	
DIXI 7562 Ø 6.00 - 20.00		2	125	L ₁ = 1.5 x Ø		✓	✓	
DIXI 7572 Ø 3.00 - 20.00		2	126	L ₁ = 3-5 x Ø		✓	✓	✓
DIXI 7232 Ø 2.00 - 8.00		2	126	L ₁ = 1.5-3 x Ø 		✓		

FRAISES EN BOUT Z=3

DIXI 7243 Ø 0.35 - 20.00		3	127	L ₁ = 1.5-3 x Ø 		✓	✓	
DIXI 7203 Ø 2.00 - 20.00		3	129	L ₁ = 2-4 x Ø		✓	✓	
DIXI 7223 Ø 3.00 - 20.00		3	130	L ₁ = 3-10 x Ø		✓	✓	✓
DIXI 7333 Ø 0.30 - 10.00		3	131	L ₁ = 1 x Ø		✓	✓	
DIXI 7333-3D Ø 0.30 - 4.00		3	132	L ₁ = 1 x Ø L ₂ = 3 x Ø		✓	✓	
DIXI 7333-5D Ø 0.30 - 3.00		3	132	L ₁ = 1 x Ø L ₂ = 5 x Ø		✓	✓	



○ bien ⊙ excellent

Acier + Pb	Acier faibl. allié	Aciers fort. allié	Acier inox aust.	Aciers Fontes 45-65 HRC	Fontes	Super alliages Ni / Co	Titane, alliages de titane	Alliage Cu Argent Or	Alliage Cu difficile	Alu	Graphite	Plastique
------------	--------------------	--------------------	------------------	-------------------------	--------	------------------------	----------------------------	----------------------	----------------------	-----	----------	-----------

⊙	○	○	○		⊙	○	⊙	⊙	⊙	○		○
⊙	○	○	○		⊙	○	⊙	⊙	⊙	○		○
⊙	○	○	○		⊙	○	⊙	⊙	⊙	○		○
○					○		⊙	○	○	⊙		○
○					○		⊙	○	○	⊙		○
○								○	○	⊙	⊙	○
⊙	○				○			⊙		⊙		○

⊙	○	○	○		⊙		○	⊙	○	⊙		○
⊙	○	○	○		⊙		○	⊙	○	⊙		○
⊙	○	○	○		⊙		○	⊙	○	⊙	⊙	○
⊙	○	○	⊙		⊙	○	⊙	⊙	⊙	○		○
⊙	○	○	⊙		⊙	○	⊙	⊙	⊙	○		○
⊙	○	○	⊙		⊙	○	⊙	⊙	⊙	○		○



SELECTION DES FRAISES

✓ = article de stock

FRAISES EN BOUT Z=3		Z	Page			<input type="checkbox"/> CARBURE	<input type="checkbox"/> TiAlN	<input type="checkbox"/> CUTINOX	<input type="checkbox"/> XIDUR	<input type="checkbox"/> DAC	<input type="checkbox"/> DIAMANT
DIXI 7333-8D Ø 0.30 - 3.00		3	132	L ₁ = 1 x Ø L ₂ = 8 x Ø		✓		✓			
DIXI 7543 Ø 1.00 - 12.00		3	134	L ₁ = 1 - 2 x Ø					✓		
DIXI 7583 Ø 0.30 - 6.00		3	135	L ₁ = 2 x Ø		✓	✓				
DIXI 7253 Ø 3.00 - 20.00		3	136	L ₁ = 1 x Ø L ₂ = 3 x Ø				✓			
DIXI 7273 Ø 3.00 - 20.00		3	136	L ₁ = 1.5-3.5 x Ø		✓	✓				
DIXI 7593 Ø 6.00 - 20.00		3	137	L ₁ = 1 x Ø L ₂ = 4-5.5 x Ø		✓					
DIXI 7210 Ø 3.00 - 12.00		3	137	L ₁ = 2 x Ø		✓		✓			
DIXI 7213 Ø 4.00 - 20.00		3	138	L ₁ = 1.5-2.5 x Ø		✓	✓				
DIXI 7215 Ø 6.00 - 16.00		3	138	L ₁ = 2 x Ø						✓	
FRAISES EN BOUT Z=4											
DIXI 7244 Ø 0.40 - 20.00		4	139	L ₁ = 2-3.5 x Ø 		✓	✓				✓
DIXI 7204 Ø 2.00 - 6.00		4	140	L ₁ = 2.5-4 x Ø		✓	✓				
DIXI 7224 Ø 3.00 - 20.00		4	140	L ₁ = 3-10 x Ø		✓	✓				✓
DIXI 7264 Ø 1.50 - 20.00		4	141	L ₁ = 2-3 x Ø 				✓			



○ bien ⊙ excellent

Acier + Pb	Acier faibl. allié	Aciers fort. allié	Acier inox aust.	Aciers Fontes 45-65 HRC	Fontes	Super alliages Ni / Co	Titane, alliages de titane	Alliage Cu Argent Or	Alliage Cu difficile	Alu	Graphite	Plastique
------------	--------------------	--------------------	------------------	-------------------------	--------	------------------------	----------------------------	----------------------	----------------------	-----	----------	-----------

⊙	○	○	⊙		⊙	○	⊙	⊙	⊙	○		○
⊙	○	○	○		○		○					
○	○	○	⊙		○		⊙	○	⊙	○		○
○	⊙	⊙	⊙		○	⊙	⊙					
⊙	○				○		○	○	○	⊙		○
										⊙		
⊙	⊙	○	⊙		○		⊙	○	○	⊙		
⊙	○	○	○		○		○	○	○	○		
								○		⊙		

⊙	○	○	○		⊙		○	⊙	○	⊙	⊙	○
⊙	○	○	○		⊙		○	⊙	○	⊙		○
⊙	○				○		○	⊙	○	⊙	⊙	○
○	⊙	⊙	⊙		○	⊙	⊙					



SELECTION DES FRAISES

✓ = article de stock

FRAISES EN BOUT Z=4		Z	Page			<input type="checkbox"/> CARBURE	TiAIN	CUTINOX	DICUT	XIDUR	DLC
DIXI 7264 3-D Ø 6.00 - 20.00		4	141	L ₁ = 2 x Ø L ₂ = 3 x Ø				✓			
DIXI 7254 Ø 3.00 - 20.00		4	142	L ₁ = 1-1.5 x Ø L ₂ = 3 x Ø				✓			
DIXI 7214 Ø 6.00 - 20.00		4	142	L ₁ = 2-2.5 x Ø		✓	✓				
FRAISES MULTIDENTS											
DIXI 7560 Ø 0.35 - 20.00		3-8	143	L ₁ = 2-4 x Ø		✓	✓				✓
DIXI 7520 Ø 0.40 - 16.00		3-10	144	L ₁ = 2 x Ø						✓	
FRAISES HAUTE AVANCE											
DIXI 7702 Ø 0.50 - 12.00		2	145	L ₂ = 3 x Ø						✓	
FRAISES TORIQUES											
DIXI 7237-10 Ø 0.40 - 3.00		2	146	L ₁ = 1 x Ø L ₂ = 3 x Ø		✓	✓				
DIXI 7070 Ø 3.00 - 12.00		4-6	147	L ₁ = 1-1.5 x Ø L ₂ = 2.5-4 x Ø						✓	
DIXI 7265 Ø 2.00 - 12.00		4	148	L ₁ = 2 x Ø				✓			
DIXI 7554 Ø 2.00 - 12.00		4	149	L ₁ = 1-1.5 x Ø L ₂ = 3-5 x Ø		✓	✓				
DIXI 7552 Ø 3.00 - 16.00		2	150	L ₁ = 1-1.5 x Ø L ₂ = 2.5-3.5 x Ø		✓			✓		



○ bien ⊙ excellent

Acier + Pb	Acier faibl. allié	Aciers fort. allié	Acier inox aust.	Aciers Fontes 45-65 HRC	Fontes	Super alliages Ni / Co	Titane, alliages de titane	Alliage Cu Argent Or	Alliage Cu difficile	Alu	Graphite	Plastique
------------	--------------------	--------------------	------------------	-------------------------	--------	------------------------	----------------------------	----------------------	----------------------	-----	----------	-----------

○	⊙	⊙	⊙		○	⊙	⊙					
○	⊙	⊙	⊙		○	⊙	⊙					
⊙	○	○	○		⊙		○	○	○	○		

⊙	⊙	○	⊙		⊙	○	○	⊙	⊙			
		○		⊙		○						

⊙	⊙	⊙	⊙	⊙	⊙	⊙	⊙	⊙	⊙	○	○	
---	---	---	---	---	---	---	---	---	---	---	---	--

⊙	○	○	○		⊙	○	⊙	⊙	⊙	○		○
		○		⊙		○						
⊙	○	○	○		⊙		⊙	○	○	○		○
⊙	○	○	○		⊙		⊙	○	○	○		○
○	○				○		⊙	○	⊙	○		○



SELECTION DES FRAISES

✓ = article de stock

FRAISES HÉMISPHERIQUES				Z	Page		<input type="checkbox"/> CARBURE	<input type="checkbox"/> TITAIN	<input type="checkbox"/> DICUT	<input type="checkbox"/> XIDUR	<input type="checkbox"/> DIAMANT
DIXI 7032 Ø 0.06 - 20.00		30°		2	151	$L_1 = 1.5-2 \times \emptyset$	✓	✓	✓		✓
DIXI 7042 Ø 2.00 - 20.00		30°		2	152	$L_1 = 2-5 \times \emptyset$	✓	✓			✓
DIXI 7046 Ø 0.20 - 12.00		30°		2	153	$L_1 = 1-2.5 \times \emptyset$ $L_2 = 2.5-6 \times \emptyset$	✓	✓	✓		✓
DIXI 7045 Ø 0.20 - 12.00		30°		2	154	$L_1 = 1-2.5 \times \emptyset$ $L_2 = 2.5-6 \times \emptyset$	✓	✓	✓		✓
DIXI 7047-8D Ø 0.20 - 12.00		30°		2	154	$L_1 = 1-2.5 \times \emptyset$ $L_2 = 8 \times \emptyset$	✓	✓	✓		✓
DIXI 7047-10D Ø 0.20 - 12.00		30°		2	154	$L_1 = 1-2.5 \times \emptyset$ $L_2 = 10 \times \emptyset$	✓	✓	✓		✓
DIXI 7047-12D Ø 0.20 - 5.00		30°		2	154	$L_1 = 1-2.5 \times \emptyset$ $L_2 = 12 \times \emptyset$	✓	✓	✓		✓
DIXI 7047-15D Ø 0.20 - 4.00		30°		2	154	$L_1 = 1-2.5 \times \emptyset$ $L_2 = 15 \times \emptyset$	✓	✓	✓		✓
DIXI 7047-18D Ø 0.20 - 3.00		30°		2	154	$L_1 = 1-2.5 \times \emptyset$ $L_2 = 18 \times \emptyset$	✓	✓	✓		✓
DIXI 7532 Ø 0.20 - 10.00		30°		2	156	$L_1 = 1 \times \emptyset$				✓	
DIXI 7532-3D Ø 0.20 - 10.00		30°		2	157	$L_1 = 1 \times \emptyset$ $L_2 = 3 \times \emptyset$				✓	
DIXI 7532-5D Ø 0.20 - 10.00		30°		2	157	$L_1 = 1 \times \emptyset$ $L_2 = 5 \times \emptyset$				✓	
DIXI 7532-8D Ø 0.20 - 4.00		30°		2	157	$L_1 = 1 \times \emptyset$ $L_2 = 8 \times \emptyset$				✓	



○ bien ⊙ excellent

Acier + Pb	Acier faibl. allié	Aciers fort. allié	Acier inox aust.	Aciers Fontes 45-65 HRC	Fontes	Super alliages Ni / Co	Titane, alliages de titane	Alliage Cu Argent Or	Alliage Cu difficile	Alu	Graphite	Plastique
⊙	○	○	○		⊙	○	○	⊙	○	⊙	⊙	⊙
⊙	○	○	○		⊙	○	○	⊙	○	⊙	⊙	⊙
⊙	⊙	⊙	⊙		○	○	⊙	○	⊙	○	⊙	○
⊙	⊙	⊙	⊙		○	○	⊙	○	⊙	○	⊙	○
⊙	⊙	⊙	⊙		○	○	⊙	○	⊙	○	⊙	○
⊙	⊙	⊙	⊙		○	○	⊙	○	⊙	○	⊙	○
⊙	⊙	⊙	⊙		○	○	⊙	○	⊙	○	⊙	○
⊙	⊙	⊙	⊙		○	○	⊙	○	⊙	○	⊙	○
⊙	⊙	⊙	⊙		○	○	⊙	○	⊙	○	⊙	○
		○		⊙		○						
		○		⊙		○						
		○		⊙		○						
		○		⊙		○						



SELECTION DES FRAISES

✓ = article de stock

FRAISES HÉMISPHERIQUES		Z	Page			CARBURE	TiAIN	XIDUR	PCD	DIA
DIXI 7532-10D Ø 0.40 - 3.00		2	157	$L_1 = 1 \times \emptyset$ $L_2 = 10 \times \emptyset$				✓		
DIXI 7532-12D Ø 0.50 - 2.00		2	157	$L_1 = 1 \times \emptyset$ $L_2 = 12 \times \emptyset$				✓		
DIXI 7532-15D Ø 0.60 - 2.00		2	157	$L_1 = 1 \times \emptyset$ $L_2 = 15 \times \emptyset$				✓		
DIXI 7542 Ø 1.00 - 12.00		2	158	$L_1 = 1.5-2 \times \emptyset$ $L_2 = 3 \times \emptyset$				✓		
DIXI 7033 Ø 1.00 - 12.00		3	159	$L_1 = 1.5-2 \times \emptyset$		✓	✓			
DIXI 7034 Ø 6.00 - 20.00		4	159	$L_1 = 1.5 \times \emptyset$		✓	✓			
FRAISES DIAMANT										
DIXI 72420 PCD Ø 1.00 - 20.00		1 - 2	160	$L_1 = 1-1.5 \times \emptyset$ $L_2 = 1.5-6 \times \emptyset$					✓	
DIXI 70520 PCD Ø 1.00 - 20.00		1 - 2	161	$L_1 = 1-1.5 \times \emptyset$ $L_2 = 1.5-6 \times \emptyset$					✓	
DIXI 70600 PCD Ø 1.00 - 6.00		1	162	$L_1 = 1.5 \times \emptyset$					✓	
DIXI 70600 DIA Ø 3.00 - 6.00		1	162	$L_1 = 2 \times \emptyset$						✓
DIXI 72310 DIA Ø 0.30 - 2.00		1	163	$L_1 = 1-2.5 \times \emptyset$						✓



○ bien ⊙ excellent

Acier + Pb	Acier faibl. allié	Aciers fort. allié	Acier inox aust.	Aciers Fontes 45-65 HRC	Fontes	Super alliages Ni / Co	Titane, alliages de titane	Alliage Cu Argent Or	Alliage Cu difficile	Alu	Graphite	Plastique
		○		⊙		○						
		○		⊙		○						
		○		⊙		○						
		○		⊙		○						
⊙	⊙	⊙	○		⊙	○	○	⊙		⊙		⊙
⊙	⊙	⊙	○		⊙	○	○	○	○	○		○

								⊙	⊙	⊙	⊙	⊙
								⊙	⊙	⊙	⊙	⊙
								⊙	⊙	⊙	⊙	⊙
								⊙	○	⊙		⊙
								⊙	○	⊙		⊙



SELECTION DES FRAISES

✓ = article de stock

		Z	Page			<input type="checkbox"/> CARBURE	<input type="checkbox"/> TITAIN	<input type="checkbox"/> PCD	<input type="checkbox"/> DIA
FRAISES DIAMANT									
DIXI 72421 DIA Ø 6.00 - 12.00		1	164						✓
DIXI 70320 PCD Ø 2.00 - 20.00		1 - 2	165	$L_1 = 0.5-1 \times \varnothing$ $L_2 = 1.5-6 \times \varnothing$				✓	
DIXI 76230 DIA Ø 0.10 - 0.30		1	166						✓
FRAISES À CHANFREINER ET RAYONNER									
DIXI 7623 Ø 0.80 - 12.00		3	166			✓	✓		
DIXI 7624 Ø 0.20 - 5.70		1 - 4	167			✓			
DIXI 7656 R 0.10 - 1.00		2	168			✓	✓		
FRAISES POUR COMPOSITES / KEVLAR®									
DIXI 7112 Ø 5.00 - 12.70		2	168	$L_1 = 2 - 4 \times \varnothing$		✓			

○ bien ⊙ excellent

Acier + Pb	Acier faibl. allié	Aciers fort. allié	Acier inox aust.	Aciers Fontes 45-65 HRC	Fontes	Super alliages Ni / Co	Titane, alliages de titane	Alliage Cu Argent Or	Alliage Cu difficile	Alu	Graphite	Plastique
------------	--------------------	--------------------	------------------	-------------------------	--------	------------------------	----------------------------	----------------------	----------------------	-----	----------	-----------

												⊙
								⊙	⊙	⊙	⊙	⊙
								⊙	○	⊙		⊙

⊙	○	○	○		⊙	○	⊙	⊙	⊙	⊙		⊙
⊙	○	○	○		⊙	○	⊙	⊙	⊙	⊙		⊙
⊙	○	○	○		⊙	○	⊙	⊙	⊙	⊙		⊙

Kevlar®

												⊙
--	--	--	--	--	--	--	--	--	--	--	--	---



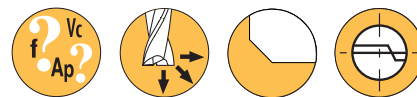

P. 212

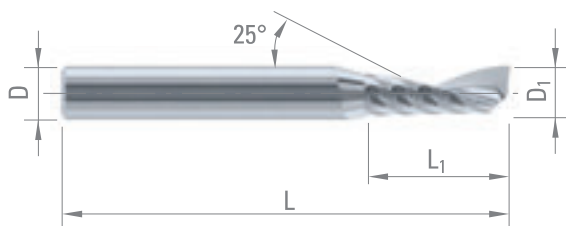

Alliage Cu
Argent
Or

Alu

Plastique

D_1 e8		L_1	D_{h5}	L	CARBURE
2.00	0.10 x 45°	4.0	3	38	46560
3.00	0.15 x 45°	6.0	3	38	46561
4.00	0.15 x 45°	12.0	4	50	46562
5.00	0.15 x 45°	14.0	5	50	46563
6.00	0.20 x 45°	16.0	6	50	46564
8.00	0.20 x 45°	20.0	8	60	46565
10.00	0.20 x 45°	22.0	10	70	46566
12.00	0.20 x 45°	25.0	12	70	46567

DIXI 7301

FRAISES 1 DENT - COURTES

Z = 1

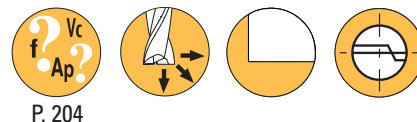

P. 204

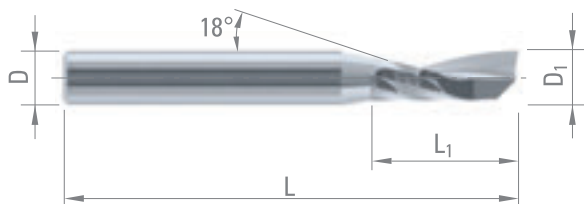

Plastique

$D_{1\ e8}$	L_1	D_{h5}	L	CARBURE
2.00	6.0	3	38	965241
3.00	12.0	3	50	963955
4.00	16.0	4	50	964011
5.00	16.0	5	50	964012
6.00	16.0	6	50	964014
8.00	23.0	8	50	964016

DIXI 7302

FRAISES 1 DENT - LONGUES

Z = 1

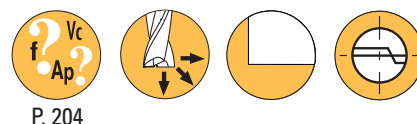

P. 204

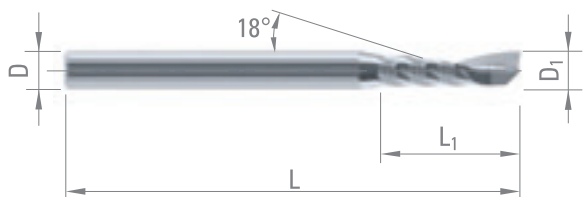

Plastique

$D_{1\ e8}$	L_1	D_{h5}	L	CARBURE
3.00	17.0	3	61	963956
4.00	23.0	4	61	964031
5.00	23.0	5	61	964032
6.00	23.0	6	75	964033
8.00	32.0	8	75	964034
10.00	33.0	10	75	964093
12.00	33.0	12	100	964094



FRAISES 1 DENT - LONGUES
CORPS RENFORCÉ

Z = 1

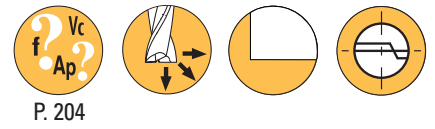

P. 204

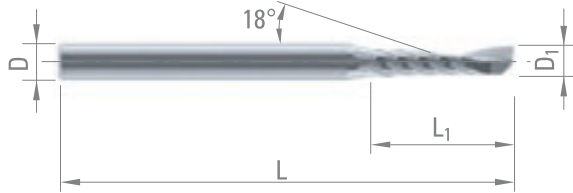

Plastique

$D_{1\ e8}$	L_1	D_{h5}	L	CARBURE
2.00	8.0	6	50	964147
3.00	18.0	6	75	963957
4.00	23.0	6	75	964079
5.00	23.0	6	75	964084



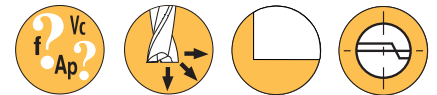

P. 202

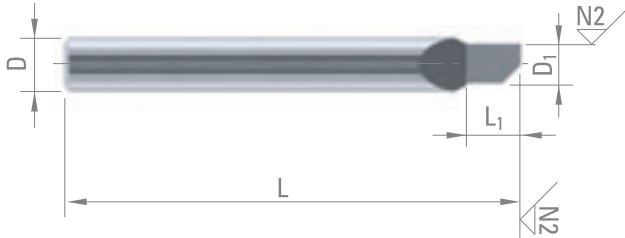

Acier
+ Pb

Fontes

Alliage Cu
Argent
Or

Alliage
Cu
difficile

Alu

Plastique

$D_{1 \pm 0.01}$	L_1	D_{h5}	L	CARBURE
0.50	1.0	4	35	965456
0.60	1.2	4	35	965457
0.70	1.5	4	35	965458
0.80	1.5	4	35	960645
0.90	1.5	4	35	960646
1.00	1.5	4	35	960647
1.00 >	2.5	4	35	964328
1.10	2.0	4	35	960648
1.20	2.0	4	35	960649
1.30	2.0	4	35	960650
1.40	2.0	4	35	960651
1.50	2.0	4	35	960652
1.60	2.0	4	35	960653
1.70	2.5	4	35	960654
1.80	2.5	4	35	960655
1.90	2.5	4	35	960656
2.00	2.5	4	35	960657
2.50	3.0	4	35	960658
3.00	3.5	4	42	960659
3.50	4.0	4	42	960660
4.00	5.0	4	42	960661
4.50	6.0	6	50	960662
5.00	7.0	6	50	960663
6.00	7.0	8	50	960664

DIXI 7063

FRAISES 1 DENT 3/4

Z = 1



P. 202

$\emptyset 0.40 \leq \emptyset 1.80$



$\emptyset 1.80 \leq \emptyset 4.00$

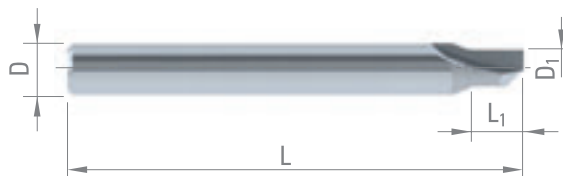

Alliage Cu
Argent
Or

Alliage
Cu
difficile

Alu

Plastique

$D_{1 \pm 0.01}$	L_1	D_2	L_2	D_{h5}	L	CARBURE
0.40	0.8	1.5	4.6	4	35	987593
0.50	1.0	1.5	4.6	4	35	983250
0.60	1.2	1.5	4.6	4	35	987594
0.70	1.5	1.5	4.6	4	35	987595
0.80	1.5	1.5	4.6	4	35	987596
0.90	1.5	2.0	5.1	4	35	987581
1.00	1.5	2.0	5.1	4	35	983251
1.00 >	2.5	2.0	5.1	4	35	987582
1.10	2.5	2.0	6.0	4	35	987597
1.20	2.5	2.0	6.0	4	35	987598
1.30	2.5	3.0	6.0	4	35	987599
1.40	2.5	3.0	6.0	4	35	987583
1.50	2.5	3.0	6.0	4	35	983252
1.50 >	3.5	3.0	6.5	4	35	987600
1.60	3.5	3.0	6.5	4	35	987585
1.70	3.5	3.0	6.5	4	35	987586

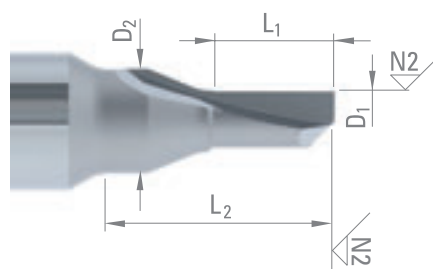

$D_{1 \pm 0.01}$	L_1	D_{h5}	L	CARBURE
1.80	3.5	4	35	987601
1.90	3.5	4	35	987602
2.00	4.0	4	35	983253
2.20	4.0	4	35	987603
2.50	4.0	4	35	987604
2.80	4.0	4	35	987605
3.00	4.0	4	35	983254
4.00	5.0	4	35	987584

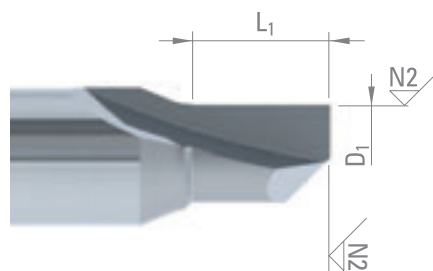

DIXI 7242

FRAISES EN BOUT HÉLICOÏDALES CORPS RENFORCÉ

Z = 2



P. 180



D₁ > 6

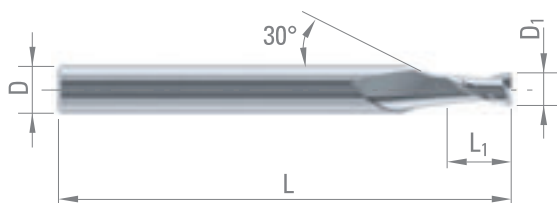

Acier + Pb	Acier faibl. allié	Acier fort. allié	Acier inox aust.	Fontes
Titane, alliage de titane	Alliage Cu Argent Or	Alliage Cu difficile	Alu	Plastique

D ₁	L ₁	D _{h5}	L	CARBURE	TiAIN
Ø < 2.00 - 0/-0.01					
Ø < 3.00 - 0/-0.02					
Ø ≥ 3.00 - e8					
0.15	0.3	3	38	52628	64920
0.20	0.4	3	38	45705	60021
0.25	0.6	3	38	47916	64921
0.30	0.6	3	38	42172	60121
0.30 >	1.0	3	38	48850	60122
0.35	0.8	3	38	47917	950699
0.40	0.8	3	38	42126	60123
0.40 >	2.0	3	38	48851	60124
0.45	1.0	3	38	47918	952421
0.50	1.0	3	38	35241	36230
0.50 >	2.5	3	38	48852	60125
0.55	1.2	3	38	47921	952422
0.60	1.2	3	38	35242	36231
0.60 >	3.0	3	38	48853	60126
0.65	1.4	3	38	47922	952423
0.70	1.4	3	38	35243	36232
0.70 >	3.5	3	38	48854	57162
0.75	1.6	3	38	47923	57163
0.80	1.6	3	38	35244	36233
0.80 >	4.0	3	38	48855	57164
0.85	1.8	3	38	47066	57165
0.90	1.8	3	38	35245	36234
0.90 >	4.5	3	38	48856	57166
0.95	2.0	3	38	42846	57167
1.00	2.0	3	38	35246	36235
1.00 >	5.0	3	38	42735	55950
1.05	2.2	3	38	47924	57168
1.10	2.2	3	38	35247	57169
1.15	2.4	3	38	47925	57170
1.20	2.4	3	38	35248	36237
1.20 >	6.0	3	38	48857	57171
1.25	2.6	3	38	47926	57172
1.30	2.6	3	38	35249	57173
1.35	2.8	3	38	47927	57174
1.40	2.8	3	38	35250	36239
1.45	3.0	3	38	47928	57175
1.50	3.0	3	38	38489	36240
1.50 >	7.0	3	38	48858	57176



DIXI 7242



P. 180



$D_1 > 6$



D_1 $\emptyset < 2.00 - 0/-0.01$ $\emptyset < 3.00 - 0/-0.02$ $\emptyset \geq 3.00 - e8$	L_1	D_{h5}	L	CARBURE	TIAIN
1.60	3.2	3	38	38490	57177
1.70	3.4	3	38	38491	44939
1.80	3.6	3	38	42096	38613
1.90	4.0	3	38	38493	57178
2.00	6.0	3	38	42784	39577
2.10	7.0	3	38	44058	64794
2.20	7.0	3	38	43956	64795
2.30	7.0	3	38	44877	60627
2.40	7.0	3	38	43527	64796
2.50	7.0	3	38	42201	36242
3.00	7.0	6	57	41806	46440
3.50	7.0	6	57	43353	57179
4.00	8.0	6	57	41856	57180
4.50	8.0	6	57	42202	57181
5.00	10.0	6	57	41996	36247
5.50	10.0	6	57	41807	57182
6.00	10.0	6	57	41907	57183
6.50	13.0	8	63	28932	57184
7.00	13.0	8	63	28933	57185
7.50	16.0	8	63	28934	57186
8.00	16.0	8	63	42271	57187
8.50	16.0	10	72	28936	57195
9.00	16.0	10	72	28937	57196
9.50	19.0	10	72	43038	57197
10.00	19.0	10	72	42352	57198
12.00	22.0	12	83	39944	57199
14.00	22.0	14	83	42353	57200
16.00	26.0	16	92	42354	57201
18.00	26.0	18	92	42355	57202
20.00	32.0	20	104	42356	57203

Acier + Pb	Acier faibl. allié	Acier fort. allié	Acier inox aust.	Fontes
Titane, alliage de titane	Alliage Cu Argent Or	Alliage Cu difficile	Alu	Plastique

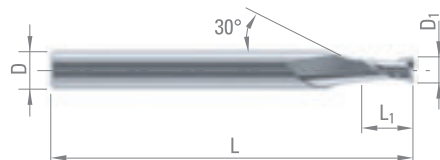

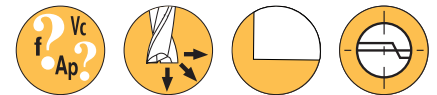

P. 180

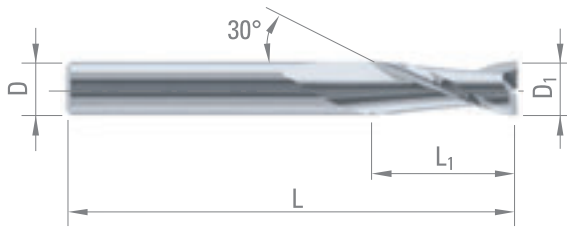

Acier + Pb	Acier faibl. allié	Acier inox aust.	Titane, alliage de titane	Alliage Cu Argent Or
Alliage Cu difficile	Alu	Graphite	Plastique	

D_1 e8 $\emptyset < 2.00 - 0/-0.01$ $\emptyset \geq 2.00 - e8$	L_1	D_{h5}	L	CARBURE	TiAlN	DIAMANT
1.50	6	2.0	32	690	57063	
2.00	8	2.0	32	691	57064	61616
2.50	8	2.5	32	692	57065	
3.00	10	3.0	38	693	57066	36199
3.50	12	3.5	38	34760	57067	
4.00	12	4.0	50	694	57068	63847
4.50	12	4.5	50	41135	57069	
5.00	14	5.0	50	34623	57070	
6.00	16	6.0	50	34624	57071	62991
7.00	18	7.0	60	29769	57072	
8.00	20	8.0	63	698	57073	67513
9.00	20	9.0	67	43726		
10.00	22	10.0	72	699	57075	
11.00	22	11.0	73	28686		
12.00	22	12.0	73	30940	57077	
13.00	25	13.0	75	30941		
14.00	25	14.0	75	27069		
15.00	25	15.0	75	28901		
16.00	27	16.0	82	27070		



FRAISES EN BOUT HÉLICOÏDALES
LONGUES

Z = 2

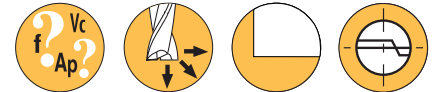

P. 196

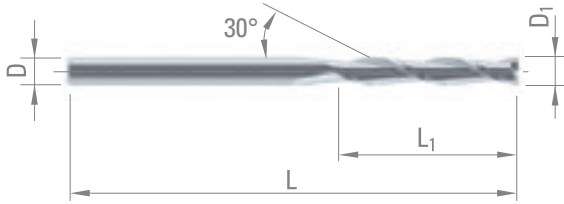

Acier + Pb	Acier faibl. allié	Acier inox aust.	Titane, alliage de titane	Alliage Cu Argent Or
Alliage Cu difficile	Alu	Graphite	Plastique	

D _{1 e8}	L ₁	D _{h5}	L	CARBURE	TiAIN	DIAMANT
3.00	30.0	3	60	44756	57124	60231
4.00	30.0	4	60	44757	57125	60232
5.00	35.0	5	75	44758	57133	60233
6.00	40.0	6	100	44759	57134	60234
8.00	40.0	8	100	44760	57135	60235
10.00	40.0	10	100	44761	57136	60236
12.00	45.0	12	100	44762	57137	60237
16.00	65.0	16	150	44764	57139	
20.00	65.0	20	150	44766	57140	



DIXI 7240

FRAISES EN BOUT EXTRA COURTES CORPS RENFORCÉ

Z = 2



P. 180

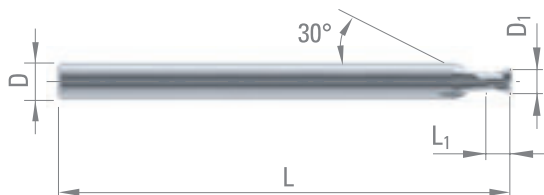

Acier + Pb	Acier faibl. allié	Acier fort. allié	Acier inox aust.	Fontes
Super alliages Ni / Co	Titane, alliage de titane	Alliage Cu Argent Or	Alliage Cu difficile	Alu
Plastique				

D ₁	L ₁	D _{h5}	L	CARBURE	TiAIN
Ø < 2.00 - 0/-0.01					
Ø < 3.00 - 0/-0.02					
Ø ≥ 3.00 - e8					
0.04	0.04	3	38	954084	
0.05	0.05	3	38	954085	
0.06	0.06	3	38	951973	
0.07	0.07	3	38	954087	
0.08	0.08	3	38	954086	
0.09	0.09	3	38	954089	
0.10	0.10	3	38	63609	64354
0.12	0.12	3	38	954090	956316
0.15	0.15	3	38	63608	64355
0.20	0.20	3	38	63610	64356
0.25	0.25	3	38	63678	64357
0.30	0.30	3	38	63679	64253
0.35	0.35	3	38	63680	64358
0.40	0.40	3	38	56551	61443
0.45	0.45	3	38	63681	64359
0.50	0.50	3	38	63682	64254
0.55	0.55	3	38	63683	64360
0.60	0.60	3	38	45571	64361
0.65	0.65	3	38	63684	64362
0.70	0.70	3	38	63685	64363
0.75	0.75	3	38	63686	64364
0.80	0.80	3	38	63687	64255
0.85	0.85	3	38	63688	64365
0.90	0.90	3	38	63689	62538
0.95	0.95	3	38	63690	64366
1.00	1.00	3	38	50547	64367
1.05	1.05	3	38	63691	64368
1.10	1.10	3	38	63692	64369
1.15	1.15	3	38	63805	64370
1.20	1.20	3	38	63806	64371
1.25	1.25	3	38	63807	64372
1.30	1.30	3	38	63808	64373
1.35	1.35	3	38	63809	64374
1.40	1.40	3	38	63810	64375
1.45	1.45	3	38	63811	64376
1.50	1.50	3	38	50548	56840
1.55	1.55	3	38	63812	64377
1.60	1.60	3	38	63813	64378
1.65	1.65	3	38	63814	64379
1.70	1.70	3	38	63815	64380
1.75	1.75	3	38	63816	64381



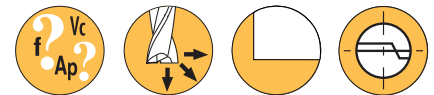

P. 180

D_1 $\emptyset < 2.00 - 0/-0.01$ $\emptyset < 3.00 - 0/-0.02$ $\emptyset \geq 3.00 - e8$	L_1	D_{h5}	L	CARBURE	TIAIN
1.80	1.80	3	38	63817	64382
1.85	1.85	3	38	63818	64383
1.90	1.90	3	38	63819	64384
1.95	1.95	3	38	63820	64385
2.00	2.00	6	50	63821	64386
2.10	2.10	6	50	63823	64387
2.20	2.20	6	50	63824	64388
2.30	2.30	6	50	63825	64389
2.40	2.40	6	50	63826	64390
2.50	2.50	6	50	63827	64391
3.00	3.00	6	50	63828	64392
3.50	3.50	6	50	63829	64393
4.00	4.00	6	50	63830	64394
4.50	4.50	6	50	63831	64395
5.00	5.00	6	50	63832	64397
5.50	5.50	6	50	63833	64398

Acier + Pb	Acier faibl. allié	Acier fort. allié	Acier inox aust.	Fontes
Super alliages Ni / Co	Titane, alliage de titane	Alliage Cu Argent Or	Alliage Cu difficile	Alu
Plastique				

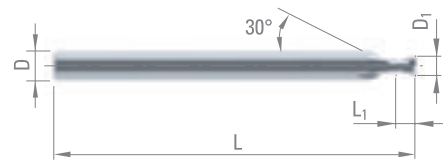

DIXI 7237 - 7238 - 7239 - 7239-D

FRAISES EN BOUT EXTRA COURTES, DÉGAGÉES

Z = 2

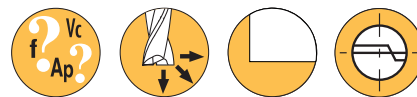

P. 180
P. 182

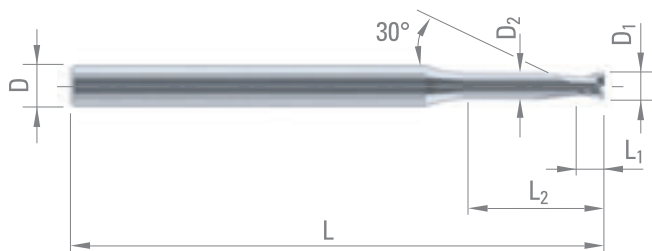

Acier + Pb	Acier faibl. allié	Acier fort. allié	Acier inox aust.	Fontes
Super alliages Ni / Co	Titane, alliage de titane	Alliage Cu Argent Or	Alliage Cu difficile	Alu
Plastique				

D₁ L₁ D₂ D_{h5} L L₂ DIXI CARBURE TiAIN

∅ < 2.00 - 0/-0.01
∅ < 3.00 - 0/-0.02
∅ ≥ 3.00 - e8

D ₁	L ₁	D ₂	D _{h5}	L	L ₂	DIXI	CARBURE	TiAIN
0.15	0.15	0.13	3	38	0.45	7237	66047	66149
0.20	0.20	0.17	3	38	0.60	7237	66068	66150
0.25	0.25	0.22	3	38	0.75	7237	66070	66151
0.30	0.30	0.27	3	38	0.90	7237	66071	66152
					1.50	7238	66196	66254
0.35	0.35	0.32	3	38	1.05	7237	66072	66153
					1.75	7238	66197	66255
0.40	0.40	0.37	3	38	1.20	7237	66073	66154
					2.00	7238	66199	66256
					3.20	7239	66296	66355
					1.35	7237	66074	66155
0.45	0.45	0.42	3	38	2.25	7238	66201	66257
					3.60	7239	66297	66356
					1.50	7237	66075	66156
					2.50	7238	66202	66258
0.50	0.50	0.45	3	38	4.00	7239	66298	66357
					5.00	7239-10D	978569	979371
					6.00	7239-12D	979313	979447
					7.50	7239-15D	979475	979497
					1.65	7237	66076	66157
					2.75	7238	66203	66259
0.55	0.55	0.50	3	38	4.40	7239	66299	66358
					5.50	7239-10D	979332	979373
					6.60	7239-12D	979413	979448
					8.25	7239-15D	979478	979498
					1.80	7237	66077	66158
0.60	0.60	0.55	3	38	3.00	7238	66205	66260
					4.80	7239	66300	66366
					6.00	7239-10D	979333	979374
					7.20	7239-12D	979416	979449
					9.00	7239-15D	979480	979499
					1.95	7237	66078	66159
					3.25	7238	66206	66261
0.65	0.65	0.60	3	38	5.20	7239	66301	66367
					6.50	7239-10D	979334	979375
					7.80	7239-12D	979417	979450
					9.75	7239-15D	979482	979500
					2.10	7237	66079	66160
					3.50	7238	66207	66262
0.70	0.70	0.65	3	38	5.60	7239	66302	66368
					7.00	7239-10D	979335	979376
					8.40	7239-12D	979419	979451
					10.50	7239-15D	979483	979503
					2.25	7237	66080	66161
					3.75	7238	66208	66263
0.75	0.75	0.70	3	38	6.00	7239	66303	66369
					7.50	7239-10D	979336	979377
					9.00	7239-12D	979420	979452
					11.25	7239-15D	979484	979505
					2.40	7237	66081	66162
0.80	0.80	0.75	3	38	4.00	7238	66209	66264
					6.40	7239	66304	66370
					8.00	7239-10D	979337	979378
					9.60	7239-12D	979421	979453
					12.00	7239-15D	979485	979506

- DIXI 7237** L₂ = 3 x D₁
- DIXI 7238** L₂ = 5 x D₁
- DIXI 7239** L₂ = 8 x D₁
- DIXI 7239-10D** L₂ = 10 x D₁
- DIXI 7239-12D** L₂ = 12 x D₁
- DIXI 7239-15D** L₂ = 15 x D₁



DIXI 7237 - 7238 - 7239 - 7239-D

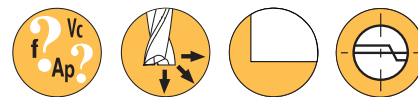

P. 180
P. 182

D ₁	L ₁	D ₂	D _{h5}	L	L ₂	DIXI	CARBURE	TiAIN
0.85	0.85	0.80	3	38	2.55	7237	66082	66164
					4.25	7238	66210	66265
					6.80	7239	66305	66371
					8.50	7239-10D	979338	979409
					10.20	7239-12D	979423	979454
					12.75	7239-15D	979486	979507
					2.70	7237	66083	66165
					4.50	7238	66211	66266
					7.20	7239	66306	66372
					9.00	7239-10D	979339	979379
0.90	0.90	0.85	3	38	10.80	7239-12D	979430	979455
					13.50	7239-15D	979487	979509
					2.85	7237	66084	66166
					4.75	7238	66212	66267
					7.60	7239	66307	66373
					9.50	7239-10D	979340	979380
					11.40	7239-12D	979431	979456
					14.25	7239-15D	979488	979510
					3.00	7237	66110	66167
					5.00	7238	66213	66268
1.00	1.00	0.95	3	38	8.00	7239	66308	66374
					10.00	7239-10D	979341	979381
					12.00	7239-12D	979206	979457
					15.00	7239-15D	979489	979511
					3.15	7237	66113	66168
					5.25	7238	66214	66269
					8.40	7239	66309	66375
					10.50	7239-10D	979342	979382
					12.60	7239-12D	979432	979458
					15.75	7239-15D	979490	979512
1.05	1.05	1.00	3	38	3.30	7237	66115	66169
					5.50	7238	66218	66270
					8.80	7239	66310	66376
					11.00	7239-10D	979343	979383
					13.20	7239-12D	979433	979459
					16.50	7239-15D	979491	979513
					3.45	7237	66116	66170
					5.75	7238	66219	66271
					9.20	7239	66313	66377
					11.50	7239-10D	979344	979384
13.80	7239-12D	979434	979460					
1.10	1.10	1.05	3	38	17.25	7239-15D	979492	979514
					3.60	7237	66117	66171
					6.00	7238	66220	66272
					9.60	7239	66314	66378
					12.00	7239-10D	979345	979385
					14.40	7239-12D	979435	979461
					18.00	7239-15D	979493	979515
					3.75	7237	66118	66172
					6.25	7238	66221	66273
					10.00	7239	66315	66379
1.15	1.15	1.10	3	38	12.50	7239-10D	979346	979386
					15.00	7239-12D	979437	979462
					18.75	7239-15D	979494	979516
					3.90	7237	66119	66173
					6.50	7238	66222	66274
					10.40	7239	66316	66380
					13.00	7239-10D	979347	979387
					15.60	7239-12D	979438	979463
					19.50	7239-15D	979495	979517
					1.20	1.20	1.15	3
6.75	7238	66223	66275					
10.80	7239	66317	66381					
13.50	7239-10D	979348	979388					
16.20	7239-12D	979439	979464					
20.25	7239-15D	979496	979518					

Acier + Pb	Acier faibl. allié	Acier fort. allié	Acier inox aust.	Fontes
Super alliages Ni / Co	Titane, alliage de titane	Alliage Cu Argent Or	Alliage Cu difficile	Alu
Plastique				

DIXI 7237 $L_2 = 3 \times D_1$

DIXI 7238 $L_2 = 5 \times D_1$

DIXI 7239 $L_2 = 8 \times D_1$

DIXI 7239-10D $L_2 = 10 \times D_1$

DIXI 7239-12D $L_2 = 12 \times D_1$

DIXI 7239-15D $L_2 = 15 \times D_1$

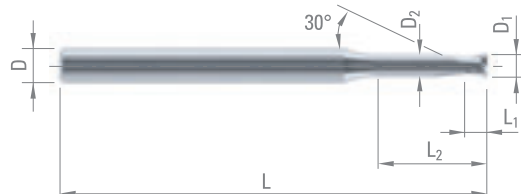

DIXI 7237 - 7238 - 7239 - 7239-D

D ₁	L ₁	D ₂	D _{h5}	L	L ₂	DIXI	CARBURE	TiAIN
$\emptyset < 2.00 - 0/-0.01$ $\emptyset < 3.00 - 0/-0.02$ $\emptyset \geq 3.00 - e8$								

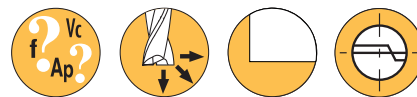

P. 180
P. 182

1.40	1.40	1.35	3	38	4.20	7237	66123	66175
					7.00	7238	66224	66276
					11.20	7239	66318	66382
					14.00	7239-10D	979349	979389
1.45	1.45	1.35	3	38	16.80	7239-12D	979440	979465
					4.35	7237	66124	66176
					7.25	7238	66225	66277
					11.60	7239	66319	66383
1.50	1.50	1.45	3	38	14.50	7239-10D	979350	979390
					17.40	7239-12D	979441	979466
					4.50	7237	66125	66177
					7.50	7238	66226	66278
1.55	1.55	1.50	3	38	12.00	7239	66320	66384
					15.00	7239-10D	979351	979391
					18.00	7239-12D	979442	979467
					4.65	7237	66126	66178
1.60	1.60	1.55	3	38	7.75	7238	66227	66279
					12.40	7239	66323	66385
					15.50	7239-10D	979352	979392
					18.60	7239-12D	979443	979468
1.65	1.65	1.60	3	38	4.80	7237	66127	66179
					8.00	7238	66228	66280
					12.80	7239	66324	66386
					16.00	7239-10D	979353	979393
1.70	1.70	1.65	3	38	19.20	7239-12D	979444	979469
					4.95	7237	66128	66180
					8.25	7238	66229	66281
					13.20	7239	66325	66387
1.75	1.75	1.70	3	38	16.50	7239-10D	979354	979394
					19.80	7239-12D	979445	979470
					5.10	7237	66129	66182
					8.50	7238	66230	66282
1.80	1.80	1.75	3	38	13.60	7239	66326	66388
					17.00	7239-10D	979355	979395
					20.40	7239-12D	979446	979471
					5.25	7237	66130	66183
1.85	1.85	1.80	3	38	8.75	7238	66231	66283
					14.00	7239	66327	66389
					17.50	7239-10D	979356	979396
					5.40	7237	66133	66184
1.90	1.90	1.85	3	38	9.00	7238	66232	66284
					14.40	7239	66328	66390
					18.00	7239-10D	979357	979398
					5.55	7237	66134	66185
1.95	1.95	1.90	3	38	9.25	7238	66233	66285
					14.80	7239	66329	66391
					18.50	7239-10D	979358	979399
					5.70	7237	66135	66186
2.00	2.00	1.95	6	50	9.50	7238	66234	66286
					15.20	7239	66330	66392
					19.00	7239-10D	979359	979400
					5.85	7237	66136	66187
2.10	2.10	2.00	6	50	9.75	7238	66235	66287
					15.60	7239	66333	66393
					19.50	7239-10D	979360	979401
					6.00	7237	66137	66188
2.20	2.20	2.10	6	50	10.00	7238	66236	66288
					16.00	7239	66334	66394
					20.00	7239-10D	979361	979402
					6.30	7237	66138	66189
2.20	2.20	2.10	6	50	10.50	7238	66237	66289
					16.80	7239	66335	66395
					21.00	7239-10D	979362	979403
					6.60	7237	66139	66190
2.20	2.20	2.10	6	50	11.00	7238	66238	66290
					17.60	7239	66350	66396
					22.00	7239-10D	979363	979404

Acier + Pb	Acier faibl. allié	Acier fort. allié	Acier inox aust.	Fontes
Super alliages Ni / Co	Titane, alliage de titane	Alliage Cu Argent Or	Alliage Cu difficile	Alu
Plastique				

DIXI 7237 $L_2 = 3 \times D_1$

DIXI 7238 $L_2 = 5 \times D_1$

DIXI 7239 $L_2 = 8 \times D_1$

DIXI 7239-10D $L_2 = 10 \times D_1$

DIXI 7239-12D $L_2 = 12 \times D_1$

DIXI 7239-15D $L_2 = 15 \times D_1$

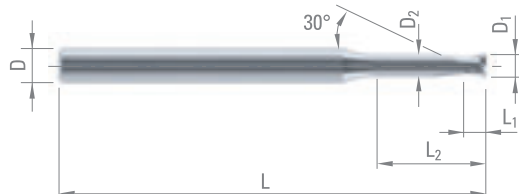

DIXI 7237 - 7238 - 7239 - 7239-D

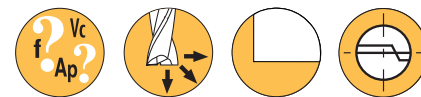

P. 180
P. 182

D ₁	L ₁	D ₂	D _{h5}	L	L ₂	DIXI	CARBURE	TIAIN
Ø < 2.00 - 0/-0.01 Ø < 3.00 - 0/-0.02 Ø ≥ 3.00 - e8								
2.30	2.30	2.20	6	50	6.90	7237	66139	66190
					11.50	7238	66239	66291
					18.40	7239	66351	66397
					23.00	7239-10D	979364	979405
					7.20	7237	66140	66191
2.40	2.40	2.30	6	50	12.00	7238	66240	66292
					19.20	7239	66352	66398
					24.00	7239-10D	979368	979406
					7.50	7237	66143	66192
					12.50	7238	66241	66293
2.50	2.50	2.40	6	50	20.00	7239	66353	66399
					25.00	7239-10D	979369	979407
					9.00	7237	66144	66193
					15.00	7238	66294	66295
					24.00	7239	66354	66400
3.00	3.00	2.90	6	50	30.00	7239-10D	979370	979408

Acier + Pb	Acier faibl. allié	Acier fort. allié	Acier inox aust.	Fontes
Super alliages Ni / Co	Titane, alliage de titane	Alliage Cu Argent Or	Alliage Cu difficile	Alu
Plastique				

DIXI 7237 $L_2 = 3 \times D_1$

DIXI 7238 $L_2 = 5 \times D_1$

DIXI 7239 $L_2 = 8 \times D_1$

DIXI 7239-10D $L_2 = 10 \times D_1$

DIXI 7239-12D $L_2 = 12 \times D_1$

DIXI 7239-15D $L_2 = 15 \times D_1$

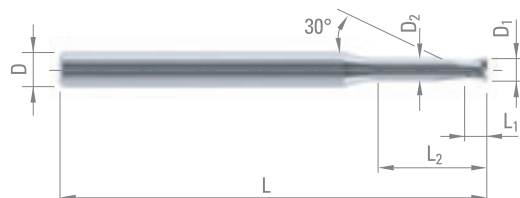

DIXI 7582

FRAISES EN BOUT HÉLICOÏDALES CORPS RENFORCÉ

Z = 2



P. 212



$D_1 \geq 2.8$

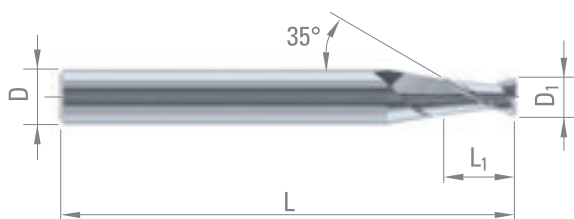

Acier + Pb	Fontes	Titane, alliage de titane	Alliage Cu Argent Or	Alliage Cu difficile
Alu	Plastique			

D_1	L_1	D_{h5}	L	CARBURE	TiAIN
$\emptyset < 2.00 - 0/-0.01$					
$\emptyset < 3.00 - 0/-0.02$					
$\emptyset \geq 3.00 - e8$					

1.00	2.0	3	38	47357	56304
1.50	3.0	3	38	47358	56305
2.00	4.0	4	50	47359	56306
2.50	5.0	4	50	47360	56307
2.80	6.0	6	50	35734	36304
3.00	6.0	6	50	30298	36305
3.80	8.0	6	50	34973	36306
4.00	8.0	6	50	30299	36607
4.50	10.0	6	50	35709	56983
5.00	10.0	6	50	30300	36309
5.50	10.0	6	50	35735	56303

DIXI 7562

FRAISES EN BOUT HÉLICOÏDALES

Z = 2



P. 212

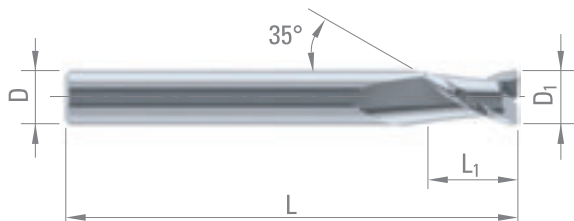

Acier + Pb	Fontes	Titane, alliage de titane	Alliage Cu Argent Or	Alliage Cu difficile
Alu	Plastique			

D_1 e8	L_1	D_{h5}	L	CARBURE	TiAIN
6.00	10.0	6	50	29100	36299
8.00	15.0	8	60	29101	36300
10.00	18.0	10	66	29102	56334
12.00	20.0	12	73	30521	36302
16.00	25.0	16	82	30523	56318
20.00	35.0	20	104	31858	56335



DIXI 7572

FRAISES EN BOUT HÉLICOÏDALES LONGUES

Z = 2



P. 212

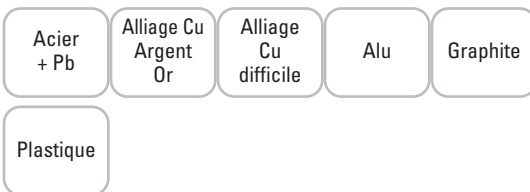
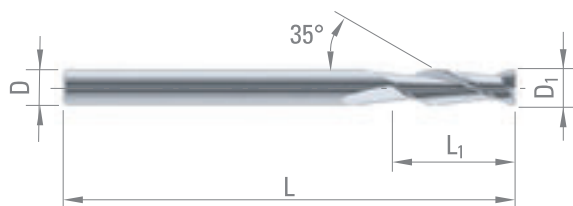

D_1 e8	L_1	D_{h5}	L	CARBURE	TiAIN	DIAMANT
3.00	14.0	3	50	32484	56320	57045
4.00	16.0	4	50	32485	56321	57046
5.00	18.0	5	60	32486	56322	57047
6.00	20.0	6	75	32487	56337	57048
7.00	22.0	7	75	32488		
8.00	25.0	8	75	32489	56336	57050
10.00	30.0	10	90	32491	56341	57052
12.00	36.0	12	100	32492	56342	
16.00	50.0	16	120	32494		
20.00	60.0	20	130	32496	56346	

DIXI 7232

FRAISES À DENTURE DROITE

Z = 2



P. 202

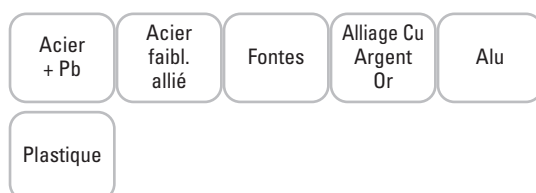
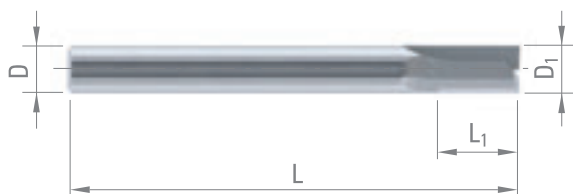

D_1 e8	L_1	D_{h5}	L	CARBURE
2.00	6.0	2	38	42540
3.00	7.0	3	38	42541
4.00	8.0	4	50	42542
6.00	10.0	6	57	42543
8.00	16.0	8	63	42544



DIXI 7243

FRAISES EN BOUT HÉLICOÏDALES CORPS RENFORCÉ

Z = 3



P. 184



$D_1 > 6$

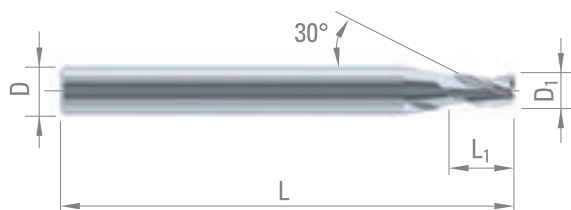

Acier + Pb	Acier faibl. allié	Acier fort. allié	Acier inox aust.	Fontes
Titane, alliage de titane	Alliage Cu Argent Or	Alliage Cu difficile	Alu	Plastique

D_1	L_1	D_{h5}	L	CARBURE	TiAIN
$\emptyset < 2.00 - 0/-0.01$					
$\emptyset < 3.00 - 0/-0.02$					
$\emptyset \geq 3.00 - e8$					
0.35	1.0	3	38	956955	956956
0.40	1.2	3	38	956957	956958
0.50	1.5	3	38	48089	60914
0.60	1.8	3	38	61842	61841
0.70	2.1	3	38	61843	61844
0.75	2.4	3	38	48090	57205
0.80	2.4	3	38	66799	61845
0.90	2.7	3	38	60383	952308
1.00	3.0	3	38	48091	57206
1.10	3.3	3	38	59356	950790
1.20	3.6	3	38	39932	61352
1.25	3.9	3	38	48092	57207
1.30	3.9	3	38	49835	950044
1.40	4.2	3	38	60201	952191
1.50	4.5	3	38	48093	57208
1.60	4.8	3	38	64985	950045
1.70	5.1	3	38	57785	67283
1.75	5.4	3	38	48094	57209
1.80	5.4	3	38	50297	66988
1.90	5.7	3	38	66798	952309
2.00	6.0	3	38	42203	40868
2.10	7.0	3	38	45168	64847
2.20	7.0	3	38	57873	67276
2.30	7.0	3	38	40848	67277
2.40	7.0	3	38	42329	64809
2.50	7.0	3	38	41909	42105
3.00	7.0	6	57	41855	42106
3.50	7.0	6	57	41928	57210
4.00	8.0	6	57	41880	42341
4.50	8.0	6	57	41808	57211
5.00	10.0	6	57	41858	42107
5.50	10.0	6	57	41910	57690
6.00	10.0	6	57	41908	35589
6.00 >	12.0	8	63	43409	57214





P. 184



$D_1 > 6$



D_1 $\emptyset < 2.00 - 0/-0.01$ $\emptyset < 3.00 - 0/-0.02$ $\emptyset \geq 3.00 - e8$	L_1	D_{h5}	L	CARBURE	TIAIN
6.50	13.0	8	63	28948	57691
7.00	13.0	8	63	42562	57217
7.50	16.0	8	63	43920	57218
8.00	16.0	8	63	28951	57692
8.00 >	15.0	10	63	41809	36267
8.50	16.0	10	72	43215	57220
9.00	16.0	10	72	28953	57221
9.50	19.0	10	72	28954	57222
10.00	19.0	10	72	42357	57223
12.00	22.0	12	83	39945	57224
14.00	22.0	14	83	27781	57225
16.00	26.0	16	92	42358	57226
18.00	26.0	18	92	42359	57227
20.00	32.0	20	104	42360	57228

Acier + Pb	Acier faibl. allié	Acier fort. allié	Acier inox aust.	Fontes
Titane, alliage de titane	Alliage Cu Argent Or	Alliage Cu difficile	Alu	Plastique

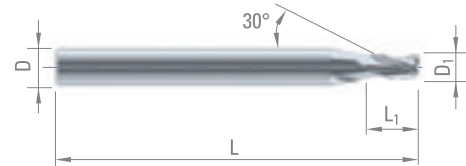



P. 184

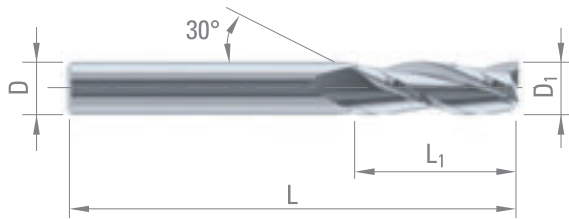

Acier + Pb	Acier faibl. allié	Acier fort. allié	Acier inox aust.	Fontes
Titane, alliage de titane	Alliage Cu Argent Or	Alliage Cu difficile	Alu	Plastique

D ₁ e8	L ₁	D _{h5}	L	CARBURE	TiAIN
2.00	8.0	2.0	32	701	57082
2.50	8.0	2.5	32	702	57089
3.00	10.0	3.0	38	703	57090
3.50	12.0	3.5	38	34761	57101
4.00	12.0	4.0	50	704	57102
5.00	15.0	5.0	50	34626	57103
6.00	18.0	6.0	50	34627	57104
7.00	20.0	7.0	60	27097	57105
8.00	25.0	8.0	63	707	57106
9.00	25.0	9.0	67	43184	57107
10.00	30.0	10.0	72	30853	57108
11.00	30.0	11.0	73	30938	57109
12.00	30.0	12.0	73	30854	57110
13.00	30.0	13.0	75	23885	57111
14.00	30.0	14.0	75	27071	57112
15.00	30.0	15.0	75	23886	57113
16.00	30.0	16.0	92	27072	57114
18.00	40.0	18.0	125	26086	57115
20.00	40.0	20.0	130	26087	57117



FRAISES EN BOUT HÉLICOÏDALES
LONGUES

Z = 3



P. 196

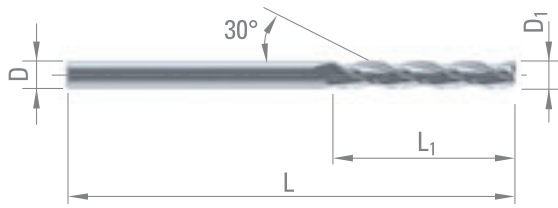

Acier + Pb	Acier faibl. allié	Acier fort. allié	Acier inox aust.	Fontes
Titane, alliage de titane	Alliage Cu Argent Or	Alliage Cu difficile	Alu	Graphite
Plastique				

D _{1 e8}	L ₁	D _{h5}	L	CARBURE	TiAIN	DIAMANT
3.00	30.0	3	60	44695	57141	60249
4.00	30.0	4	60	44696	57142	60250
5.00	35.0	5	75	44697	57143	60251
6.00	40.0	6	100	44698	57144	59009
8.00	40.0	8	100	44699	57145	60252
10.00	40.0	10	100	44700	57146	60253
12.00	45.0	12	100	44701	57147	60254
14.00	65.0	14	150	44702	57149	
16.00	65.0	16	150	44703	57150	
20.00	65.0	20	150	44705	57151	



DIXI 7333

FRAISES EN BOUT EXTRA COURTES

Z = 3



P. 198

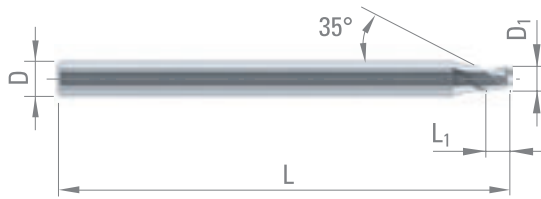

Acier + Pb	Acier faibl. allié	Acier fort. allié	Acier inox aust.	Fontes
Super alliages Ni / Co	Titane, alliage de titane	Alliage Cu Argent Or	Alliage Cu difficile	Alu
Plastique				

D_1	L_1	D_{h5}	L	CARBURE	CUTINOX
$\emptyset < 2.00 - 0/-0.01$					
$\emptyset < 3.00 - 0/-0.02$					
$\emptyset \geq 3.00 - e8$					
0.30	0.3	3	38	977779	977815
0.40	0.4	3	38	977780	977816
0.50	0.5	3	38	977781	977817
0.60	0.6	3	38	977782	977818
0.70	0.7	3	38	977783	977819
0.80	0.8	3	38	977784	977820
0.90	0.9	3	38	977785	977821
1.00	1.0	3	38	977786	977822
1.10	1.1	3	38	977787	977823
1.20	1.2	3	38	977788	977825
1.30	1.3	3	38	977789	977826
1.40	1.4	3	38	977790	977827
1.50	1.5	3	38	977791	977828
1.60	1.6	3	38	977792	977829
1.70	1.7	3	38	977793	977830
1.80	1.8	3	38	977794	977831
1.90	1.9	3	38	977795	977832
2.00	2.0	3	38	977796	977833
2.50	2.5	3	38	977797	977834
3.00	3.0	3	38	977798	977835
4.00	4.0	4	42	977799	977836
5.00	5.0	5	50	977800	977837
6.00	6.0	6	50	977801	977838
8.00	8.0	8	63	977802	977839
10.00	10.0	10	72	977803	977840



DIXI 7333-D

FRAISES EN BOUT EXTRA COURTES, DÉGAGÉES

Z = 3

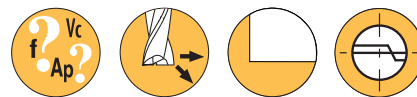

P. 198
P. 200

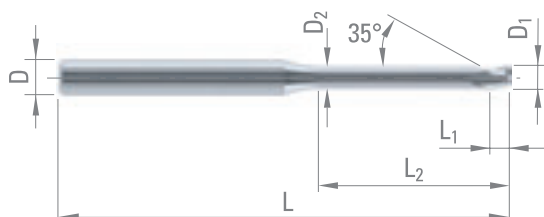

Acier + Pb	Acier faibl. allié	Acier fort. allié	Acier inox aust.	Fontes
Super alliages Ni / Co	Titane, alliage de titane	Alliage Cu Argent Or	Alliage Cu difficile	Alu
Plastique				

D₁ L₁ D₂ D_{h5} L L₂ DIXI CARBURE CUTINOX

∅ < 2.00 - 0/-0.01
∅ < 3.00 - 0/-0.02
∅ ≥ 3.00 - e8

D ₁	L ₁	D ₂	D _{h5}	L	L ₂	DIXI	CARBURE CUTINOX	
0.30	0.3	0.27	3	38	0.90	7333-3D	978791	978793
					1.50	7333-5D	978895	978896
					2.40	7333-8D	978591	978922
0.40	0.4	0.37	3	38	1.20	7333-3D	978794	978795
					2.00	7333-5D	978897	978898
					3.20	7333-8D	978928	979009
0.50	0.5	0.45	3	38	1.50	7333-3D	978796	978798
					2.50	7333-5D	978899	978900
					4.00	7333-8D	979010	979011
0.60	0.6	0.55	3	38	1.80	7333-3D	978799	978800
					3.00	7333-5D	978901	978902
					4.80	7333-8D	979012	979014
0.70	0.7	0.65	3	38	2.10	7333-3D	978801	978802
					3.50	7333-5D	978903	978904
					5.60	7333-8D	979016	979017
0.80	0.8	0.75	3	38	2.40	7333-3D	978803	978804
					4.00	7333-5D	978905	978906
					6.40	7333-8D	979018	979019
0.90	0.9	0.85	3	38	2.70	7333-3D	978805	978806
					4.50	7333-5D	978907	978908
					7.20	7333-8D	979020	979021
1.00	1.0	0.95	3	38	3.00	7333-3D	978807	978808
					5.00	7333-5D	978909	978910
					8.00	7333-8D	979022	979023
1.10	1.1	1.05	3	38	3.30	7333-3D	978809	978811
					5.50	7333-5D	978911	978912
					8.80	7333-8D	979024	979025
1.20	1.2	1.15	3	38	3.60	7333-3D	978812	978813
					6.00	7333-5D	978913	978914
					9.60	7333-8D	979026	979027
1.30	1.3	1.25	3	38	3.90	7333-3D	978814	978815
					6.50	7333-5D	978915	978916
					10.40	7333-8D	979028	979029
1.40	1.4	1.35	3	38	4.20	7333-3D	978816	978817
					7.00	7333-5D	978917	978918
					11.20	7333-8D	979030	979031
1.50	1.5	1.45	3	38	4.50	7333-3D	978818	978819
					7.50	7333-5D	978919	978920
					12.00	7333-8D	979032	979033
1.60	1.6	1.55	3	38	4.80	7333-3D	978820	978821
					8.00	7333-5D	978921	978923
					12.80	7333-8D	979034	979035
1.70	1.7	1.65	3	38	5.10	7333-3D	978823	978824
					8.50	7333-5D	978924	978925
					13.60	7333-8D	979036	979037
1.80	1.8	1.75	3	38	5.40	7333-3D	978826	978828
					9.00	7333-5D	978926	978927
					14.40	7333-8D	979038	979039
1.90	1.9	1.85	3	38	5.70	7333-3D	978829	978830
					9.50	7333-5D	978929	978930
					15.20	7333-8D	979041	979040

DIXI 7333-3D L₂ = 3 x D₁

DIXI 7333-5D L₂ = 5 x D₁

DIXI 7333-8D L₂ = 8 x D₁



DIXI 7333-D

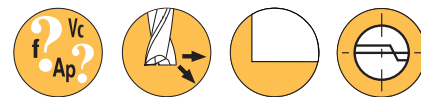

P. 198
P. 200

Acier + Pb	Acier faibl. allié	Acier fort. allié	Acier inox aust.	Fontes
Super alliages Ni / Co	Titane, alliage de titane	Alliage Cu Argent Or	Alliage Cu difficile	Alu
Plastique				

D₁ L₁ D₂ D_{h5} L L₂ DIXI CARBURE CUTINOX

Ø < 2.00 - 0/-0.01
Ø < 3.00 - 0/-0.02
Ø ≥ 3.00 - e8

2.00	2.0	1.90	3	38	6.00	7333-3D	978848	978849
					10.00	7333-5D	978931	978932
					16.00	7333-8D	979042	979043
2.50	2.5	2.40	3	38	7.50	7333-3D	978850	978851
					12.50	7333-5D	978933	978934
					20.00	7333-8D	979044	979045
3.00	2.9	2.90	3	38	9.00	7333-3D	978852	978853
					15.00	7333-5D	978935	978936
					24.00	7333-8D	979046	979047
4.00	4.0	3.80	4	42	12.00	7333-3D	978854	978855

DIXI 7333-3D L₂ = 3 x D₁

DIXI 7333-5D L₂ = 5 x D₁

DIXI 7333-8D L₂ = 8 x D₁



DIXI 7543 XIDUR

FRAISES EN BOUT HÉLICOÏDALES
CORPS RENFORCÉ

Z = 3



P. 214

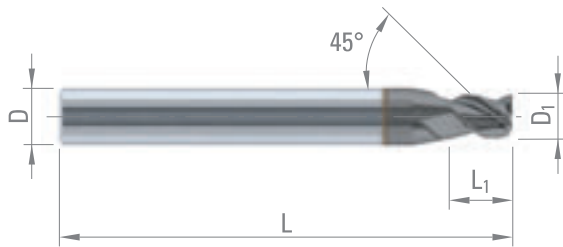

Acier
+ Pb

Acier
faibl.
allié

Acier
fort.
allié

Acier
inox
aust.

Fontes

Titane,
alliage de
titane

D₁ L₁ D_{h5} L XIDUR

Ø < 2.00 - 0/-0.01
Ø < 3.00 - 0/-0.02
Ø ≥ 3.00 - e8

1.00	2.0	4	50	51704
1.50	3.0	4	50	63945
2.00	3.0	4	50	51705
2.50	3.0	4	50	63946
3.00	4.5	6	57	51706
4.00	6.0	6	57	51707
5.00	7.0	6	57	51708
6.00	8.0	8	63	51709
8.00	10.0	10	72	51710
10.00	12.0	10	72	51711
12.00	15.0	12	83	51712



DIXI 7583

FRAISES EN BOUT HÉLICOÏDALES CORPS RENFORCÉ

Z = 3

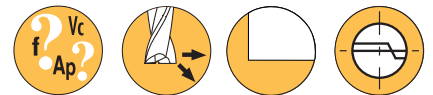

P. 184

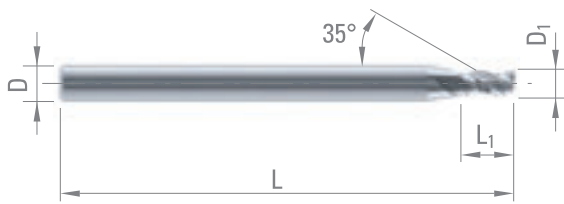

Acier + Pb	Acier faibl. allié	Acier fort. allié	Acier inox aust.	Fontes
Titane, alliage de titane	Alliage Cu Argent Or	Alliage Cu difficile	Alu	Plastique

D ₁	L ₁	D _{h5}	L	CARBURE	TiAIN	DLC
0.30	0.6	3	38	972403	972404	975572
0.40	0.8	3	38	972405	972406	982427
0.50	1.0	3	38	52565	963644	977361
0.60	1.2	3	38	963676	963678	982428
0.70	1.4	3	38	963677	963679	973037
0.80	1.6	3	38	954650	963680	982429
0.90	1.8	3	38	951666	963681	983104
1.00	2.0	3	38	31445	44659	960097
1.10	2.2	3	38	66496	66497	983105
1.20	2.4	3	38	66498	66499	973027
1.30	2.6	3	38	66500	66501	983106
1.40	2.8	3	38	66502	66503	983107
1.50	3.0	3	38	29407	40913	957103
1.60	3.2	3	38	41962	66510	983108
1.70	3.4	3	38	66504	66505	983109
1.80	3.6	3	38	66506	66507	983111
1.90	3.8	3	38	66508	66509	983112
2.00	4.0	3	38	39304	40081	61971
2.50	5.0	3	38	39213	40580	61973
3.00	6.0	6	50	40739	41954	61974
4.00	8.0	6	50	34377	53324	984169
5.00	10.0	6	50	48700	53325	984170
6.00	12.0	6	50	978074	978075	984171

Ø < 2.00 - 0/-0.01
Ø < 3.00 - 0/-0.02
Ø ≥ 3.00 - e8



DIXI 7253 CUTINOX

FRAISES À HÉLICES DIFFÉRENTES DÉGAGÉES

Z = 3

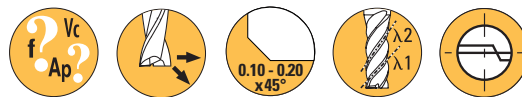

P. 186
P. 188

$D_1 \geq 10$

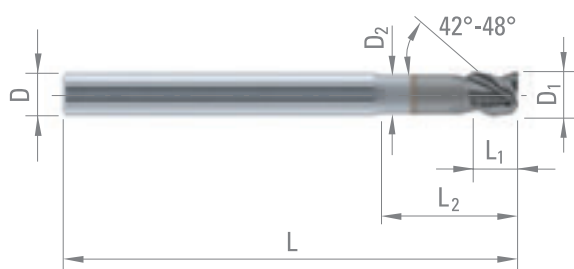

Acier + Pb	Acier faibl. allié	Acier fort. allié	Acier inox aust.	Fontes
Super alliages Ni / Co	Titane, alliage de titane			

$D_{1\text{e8}}$	L_1	D_2	L_2	D_{h5}	L	CUTINOX
3.00	4.0	2.80	9	6	57	968764
4.00	5.0	3.70	12	6	57	968765
5.00	6.0	4.60	15	6	57	968766
6.00	7.0	5.50	18	8	63	968767
8.00	9.0	7.50	24	10	72	968768
10.00	11.0	9.30	30	10	72	968769
12.00	13.0	11.20	36	12	83	968770
16.00	17.0	15.20	48	16	92	968771
20.00	21.0	19.00	60	20	104	968772

DIXI 7273

FRAISES FINITION

Z = 3

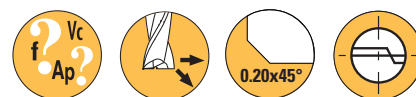

P. 184

$D_1 \geq 12$

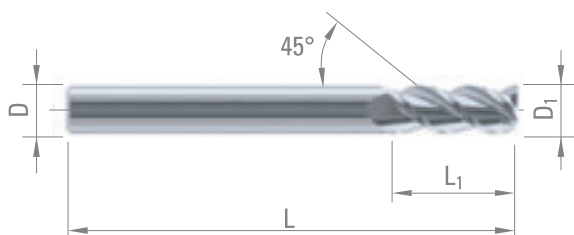

Acier + Pb	Acier faibl. allié	Fontes	Titane, alliage de titane	Alliage Cu Argent Or
Alliage Cu difficile	Alu	Plastique		

$D_{1\text{e8}}$	L_1	D_{h5}	L	CARBURE	TiAIN
3.00	10.0	3	38	35741	57254
4.00	12.0	4	50	35742	57255
5.00	14.0	5	50	34225	57256
6.00	16.0	6	57	35743	57258
8.00	20.0	8	63	34227	57259
10.00	22.0	10	72	34228	57260
12.00	22.0	12	73	34229	57261
16.00	27.0	16	82	35745	
20.00	35.0	20	104	35747	



DIXI 7593

FRAISES EN BOUT HÉLICOÏDALES
DÉGAGÉES

Z = 3-4

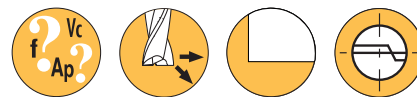

P. 214

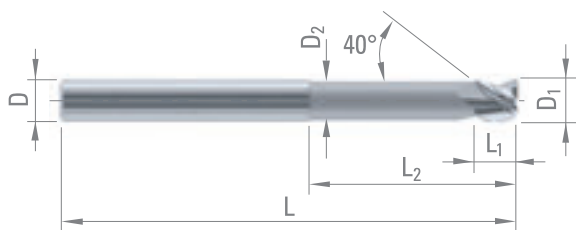

Alu

D _{1 h5}	L ₁	D ₂	L ₂	D _{h5}	L	Z	CARBURE
6.00	6.0	5.6	30	6	66	3	49281
8.00	8.0	7.6	45	8	81	3	49282
10.00	10.0	9.6	50	10	90	3	49283
12.00	12.0	11.6	55	12	100	3	49284
16.00	16.0	15.6	72	16	120	3	49285
20.00	20.0	19.6	80	20	130	4	49286

DIXI 7210

FRAISES ÉBAUCHE

Z = 3

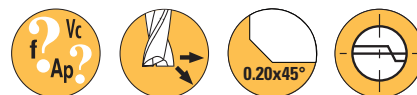

P. 204

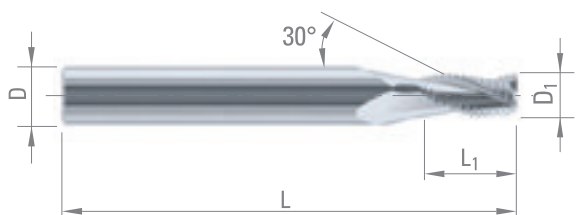

Acier
+ Pb

Acier
faibl.
allié

Acier
fort.
allié

Acier
inox
aust.

Fontes

Titane,
alliage de
titane

Alliage Cu
Argent
Or

Alliage
Cu
difficile

Alu

D _{1 d12}	L ₁	D _{h5}	L	CARBURE	CUTINOX
3.00	8.0	6	57	955178	955179
4.00	10.0	6	57	955092	955091
5.00	13.0	6	57	955089	955090
6.00	13.0	8	63	955088	955087
7.00	16.0	8	63	955086	955085
8.00	16.0	8	63	955082	955033
10.00	22.0	10	72	955093	955094
12.00	25.0	12	83	959048	956993



Sur demande

DIXI 7213

FRAISES ÉBAUCHE "PIRANHA"

Z = 3



P. 206

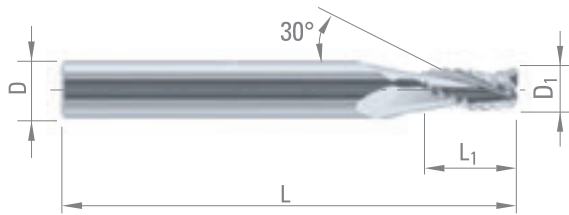

Acier + Pb	Acier faibl. allié	Acier fort. allié	Acier inox aust.	Fontes
Titane, alliage de titane	Alliage Cu Argent Or	Alliage Cu difficile	Alu	

D ₁ d12	L ₁	D _{h5}	L	CARBURE	TiAIN
4.00	10.0	6	57	31451	57018
5.00	13.0	6	57	37136	57019
6.00	13.0	8	63	37137	57020
7.00	16.0	8	63	37138	57021
8.00	16.0	10	72	43218	57022
10.00	22.0	10	72	43214	57024
11.00	22.0	12	83	37142	57025
12.00	25.0	12	83	37143	57026
14.00	27.0	14	83	37144	57027
16.00	36.0	16	100	37145	57028
20.00	40.0	20	104	37588	57029

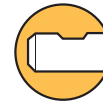

Sur demande

DIXI 7215

FRAISES ÉBAUCHE ALU

Z = 3



P. 171

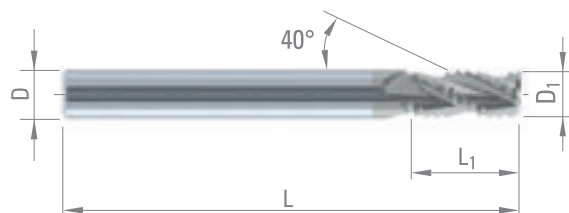

Alliage Cu Argent Or	Alliage Cu difficile	Alu
----------------------	----------------------	-----

D ₁ d12	L ₁	D _{h5}	L	DAC
6.00	13.0	6	57	993017
8.00	19.0	8	63	993018
10.00	22.0	10	72	993003
12.00	26.0	12	83	990143
16.00	32.0	16	92	993019



Sur demande

DIXI 7244

FRAISES EN BOUT HÉLICOÏDALES CORPS RENFORCÉ

Z = 4



P. 194

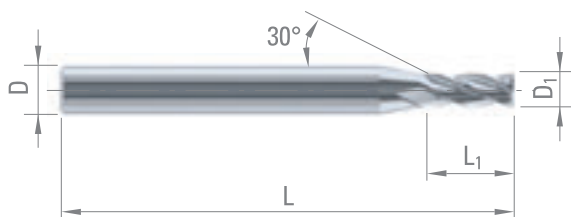

Acier + Pb	Acier faibl. allié	Acier fort. allié	Acier inox aust.	Fontes
Titane, alliage de titane	Alliage Cu Argent Or	Alliage Cu difficile	Alu	Graphite
Plastique				

D ₁	L ₁	D _{h5}	L	CARBURE	TiAlN	DIAMANT
0.40	1.2	3	38	45695	61846	
0.50	1.5	3	38	45696	61345	
1.00	3.0	3	38	55964	57230	63697
1.50	4.0	3	38	56731	57231	63698
2.00	7.0	3	38	52357	57232	63699
3.00	8.0	6	57	28959	57233	63700
4.00	11.0	6	57	42123	57239	63701
4.50	11.0	6	57	42124	57241	
5.00	13.0	6	57	41881	57242	63703
6.00	13.0	6	57	28965	57243	36278
7.00	16.0	8	63	28967	57244	
8.00	19.0	8	63	42906	57245	61617
9.00	19.0	10	72	28971	57246	
10.00	22.0	10	72	42361	57247	62563
12.00	26.0	12	83	39946	57248	
14.00	26.0	14	83	42362	57249	
16.00	32.0	16	92	42363	57251	
20.00	38.0	20	104	42227	57253	

Ø < 2.00 - 0/-0.01
Ø < 3.00 - 0/-0.02
Ø ≥ 3.00 - e8



DIXI 7204

FRAISES EN BOUT HÉLICOÏDALES

Z = 4

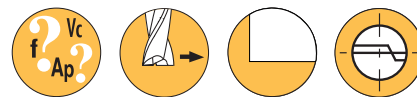

P. 194

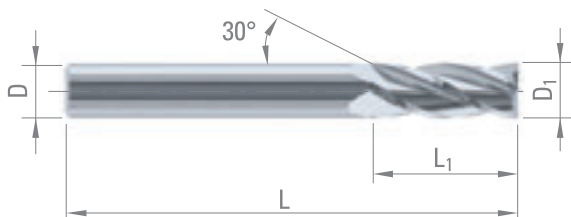

Acier + Pb	Acier faibl. allié	Acier fort. allié	Acier inox aust.	Fontes
Titane, alliage de titane	Alliage Cu Argent Or	Alliage Cu difficile	Alu	Plastique

D ₁ e8	L ₁	D _{h5}	L	CARBURE	TiAIN
2.00	8.0	2.0	32	32944	57118
2.50	8.0	2.5	32	32945	57119
3.00	10.0	3.0	38	710	57120
4.00	12.0	4.0	50	711	57121
5.00	14.0	5.0	50	34629	57122
6.00	16.0	6.0	50	34630	57123

DIXI 7224

FRAISES EN BOUT HÉLICOÏDALES LONGUES

Z = 4

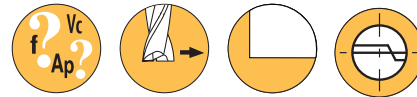

P. 196

D₁ ≥ 6

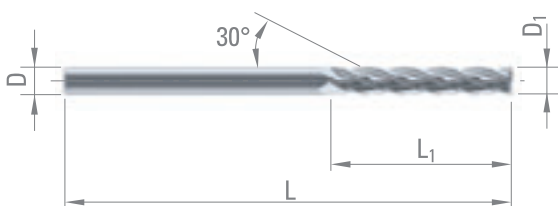

Acier + Pb	Acier faibl. allié	Fontes	Titane, alliage de titane	Alliage Cu Argent Or
Alliage Cu difficile	Alu	Graphite	Plastique	

D ₁ e8	L ₁	D _{h5}	L	CARBURE	TiAIN	DIAMANT
3.00	30.0	3	60	44769	57152	60255
4.00	30.0	4	60	44770	57154	60258
5.00	35.0	5	75	44771	57155	60259
6.00	40.0	6	100	44706	57156	60260
8.00	40.0	8	100	44772	57157	60003
10.00	40.0	10	100	44707	57158	60004
12.00	45.0	12	100	44773	57159	60261
14.00	65.0	14	150	44708	57160	
16.00	65.0	16	150	44709	55770	
20.00	65.0	20	150	44776	57161	



DIXI 7264 - 7264-3D CUTINOX

FRAISES À HÉLICES DIFFÉRENTES
ET PAS DÉCALÉ

Z = 4



P. 190
P. 192

$D_1 \geq 10$

7264

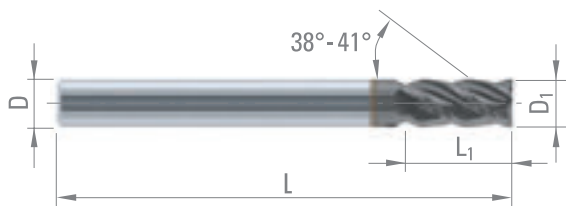

7264-3D

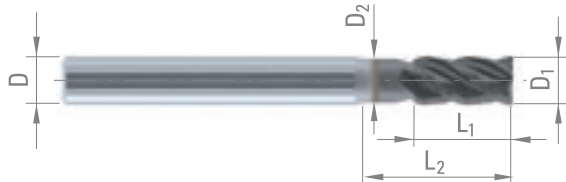

Acier
+ Pb

Acier
faibl.
allié

Acier
fort.
allié

Acier
inox
aust.

Fontes

Super
alliages
Ni / Co

Titane,
alliage de
titane

D_1
 $\emptyset < 3.00 - 0/-0.02$
 $\emptyset \geq 3.00 - e8$

D_1	L_1	D_{h5}	L	DIXI	D_2	L_2	CUTINOX
1.50	3.0	3	38	7264	-	-	974805
2.00	4.0	3	38	7264	-	-	974804
3.00	8.0	6	57	7264	-	-	968672
4.00	11.0	6	57	7264	-	-	968678
5.00	13.0	6	57	7264	-	-	968679
6.00	13.0	6	57	7264	-	-	968680
				7264-3D	5.5	18	997930
8.00	19.0	8	63	7264	-	-	968681
				7264-3D	7.5	24	997931
10.00	22.0	10	72	7264	-	-	968682
				7264-3D	9.25	30	997932
12.00	26.0	12	83	7264	-	-	968683
				7264-3D	11.0	36	997933
16.00	32.0	16	92	7264	-	-	968684
				7264-3D	15.0	48	997934
20.00	38.0	20	104	7264	-	-	968685
				7264-3D	19.0	60	997935



DIXI 7254 CUTINOX

FRAISES À HÉLICES DIFFÉRENTES
DÉGAGÉES

Z = 4

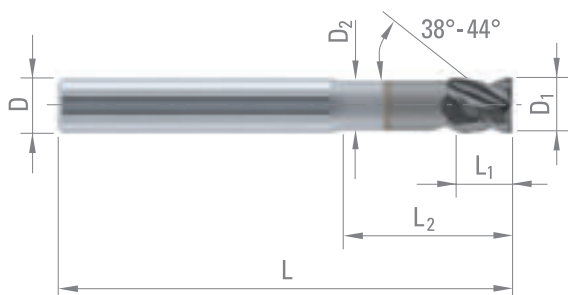

P. 186
P. 188



$D_1 \geq 10$



Acier
+ Pb

Acier
faibl.
allié

Acier
fort.
allié

Acier
inox
aust.

Fontes

Super
alliages
Ni / Co

Titane,
alliage de
titane

$D_{1\ e8}$	L_1	D_2	L_2	D_{h5}	L	CUTINOX
3.00	4.0	2.80	9	6	57	968686
4.00	5.0	3.70	12	6	57	968687
5.00	6.0	4.60	15	6	57	968688
6.00	7.0	5.50	18	8	63	968689
8.00	9.0	7.50	24	10	72	968690
10.00	11.0	9.30	30	10	72	968691
12.00	13.0	11.20	36	12	83	968692
16.00	17.0	15.20	48	16	92	968693
20.00	21.0	19.00	60	20	104	968694

DIXI 7214

FRAISES ÉBAUCHE "PIRANHA"

Z = 4

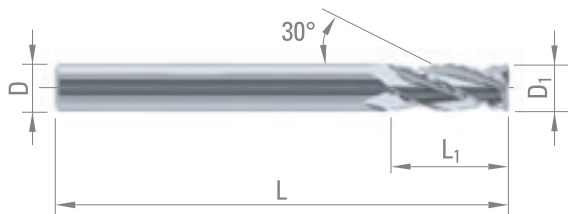

P. 206



Acier
+ Pb

Acier
faibl.
allié

Acier
fort.
allié

Acier
inox
aust.

Fontes

Titane,
alliage de
titane

Alliage Cu
Argent
Or

Alliage
Cu
difficile

Alu

Plastique

$D_{1\ d12}$	L_1	D_{h5}	L	CARBURE	TiAIN
6.00	15.0	6	57	45798	61412
8.00	16.0	10	72	39954	62426
10.00	22.0	10	72	37146	31133
12.00	25.0	12	83	37148	60949
14.00	30.0	14	83	37150	63332
16.00	36.0	16	100	37151	63333
20.00	40.0	20	104	37152	63334



Sur demande

DIXI 7560

FRAISES MULTIDENTS HÉLICOÏDALES

Z = 3-8



P. 202



D₁ > 6



D₁ ≤ 1.90

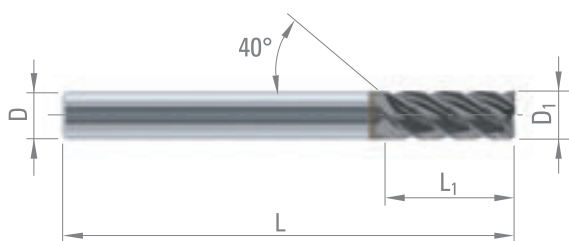

Acier + Pb	Acier faibl. allié	Acier fort. allié	Acier inox aust.	Fontes
Super alliages Ni / Co	Titane, alliage de titane	Alliage Cu Argent Or	Alliage Cu difficile	

D ₁	L ₁	D _{h5}	L	Z	CARBURE	TiAIN	DLC
0.35	0.90	3.0	38	3	964114	966117	966057
0.40	1.00	3.0	38	3	964115	966118	966058
0.45	1.10	3.0	38	3	964116	966119	966059
0.50	1.25	3.0	38	3	964117	966120	966060
0.55	1.40	3.0	38	3	964118	966121	966061
0.60	1.50	3.0	38	3	964119	966122	966062
0.65	1.70	3.0	38	3	964120	966123	966063
0.70	1.75	3.0	38	3	964121	966124	966064
0.75	1.90	3.0	38	3	964122	966125	966065
0.80	2.00	3.0	38	3	964123	966126	966066
0.85	2.15	3.0	38	3	964124	966127	966067
0.90	2.25	3.0	38	3	964125	966128	966068
0.95	2.40	3.0	38	3	964126	966129	966069
1.00	2.50	3.0	38	3	964127	966130	966070
1.10	2.75	3.0	38	3	964128	966131	966071
1.20	3.00	3.0	38	3	964129	966132	966072
1.30	3.25	3.0	38	3	964130	966133	966073
1.40	3.50	3.0	38	3	964131	966134	966074
1.50	3.75	3.0	38	3	964132	966136	966075
1.60	4.00	3.0	38	3	964133	966138	966076
1.70	4.25	3.0	38	3	964134	966139	966094
1.80	4.50	3.0	38	3	964135	966140	966095
1.90	4.75	3.0	38	3	964136	966142	966096
2.00	8.00	3.0	38	5	964108	964112	964113
2.10	5.25	3.0	38	5	964137	966145	966097
2.20	5.50	3.0	38	5	964140	966146	966098
2.30	5.75	3.0	38	5	964141	966147	966099
2.40	6.00	3.0	38	5	964142	966148	966101
2.50	8.00	3.0	38	5	964109	964110	964111
2.60	6.50	3.0	38	5	964143	966149	966102
2.70	6.75	3.0	38	5	964144	966150	966104
2.80	7.00	3.0	38	5	964145	966151	966105
2.90	7.00	3.0	38	5	964146	966152	966106
3.00	10.00	3.0	38	5	45657	49683	966107
4.00	12.00	4.0	50	5	45658	49684	964325
5.00	14.00	5.0	50	5	45659	49685	966115
6.00	16.00	6.0	57	5	45546	49686	966116
8.00	19.00	8.0	63	5	45547	49688	
9.00	22.00	9.0	67	5	45661	49689	
10.00	22.00	10.0	72	6	45548	49690	
12.00	26.00	12.0	83	6	45662	49691	
16.00	32.00	16.0	92	6	45549	49693	
20.00	38.00	20.0	104	8	45550	49694	



DIXI 7520 XIDUR

FRAISES MULTIDENTS HÉLICOÏDALES

Z = 3-10



P. 218



$D_1 \geq 6$



$D_1 \leq 1.50$

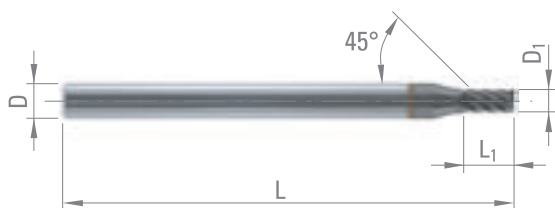

Acier
fort.
allié

Aciers
Fontes
45-65 HRC

Super
alliages
Ni / Co

D_1	L_1	D_{h5}	L	Z	XIDUR
$\varnothing < 2.00 - 0/-0.01$					
$\varnothing < 3.00 - 0/-0.02$					
$\varnothing \geq 3.00 - e8$					

0.40	0.8	3	38	3	956595
0.50	1.0	3	38	3	956596
0.60	1.2	3	38	3	956597
0.70	1.4	3	38	3	956598
0.80	1.6	3	38	3	956599
0.90	1.8	3	38	3	956600
1.00	2.0	3	38	4	956601
1.50	3.0	3	38	4	956602
2.00	4.0	3	38	5	956603
2.50	5.0	3	38	5	957465
3.00	6.0	3	38	5	49107
4.00	8.0	4	50	5	49108
6.00	12.0	6	57	6	49109
8.00	16.0	8	63	6	49110
10.00	20.0	10	72	6	49111
12.00	24.0	12	83	8	49112
16.00	32.0	16	92	10	49113



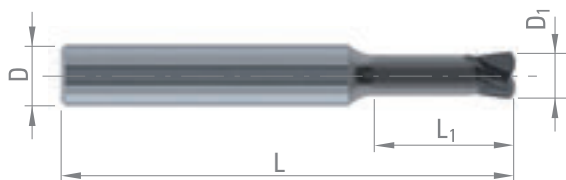

Acier + Pb	Acier faibl. allié	Acier fort. allié	Acier inox aust.	Aciers Fontes 45-65 HRC
Fontes	Super alliages Ni / Co	Titane, alliage de titane	Alliage Cu Argent Or	Alliage Cu difficile
Alu	Graphite			

D ₁	L ₁	D _{h6}	L	XIDUR
0.50	1.50	6	40	305279
0.80	2.40	6	40	305280
1.00	3.00	6	40	997920
1.50	4.50	6	40	997921
2.00	6.00	6	40	997922
3.00	9.00	6	40	997923
4.00	12.00	6	60	997924
5.00	15.00	6	60	997925
6.00	18.00	8	63	997926
8.00	24.00	10	80	997927
10.00	30.00	10	80	997928
12.00	36.00	12	80	997929

Téléchargez les conditions de coupe (pdf + xls) et les profils dxf sur www.dixipolytool.com



DIXI 7237-10

FRAISES TORIQUES EXTRA COURTES, DÉGAGÉES, $L_2 = 3 \times D_1$

Z = 2



P. 180

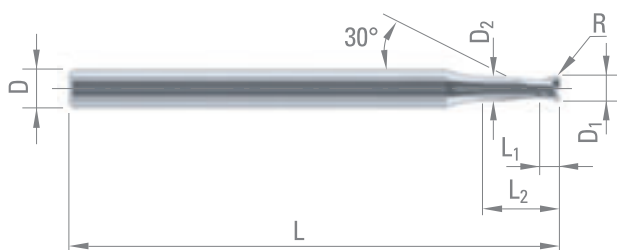

Acier + Pb	Acier faibl. allié	Acier fort. allié	Acier inox aust.	Fontes
Super alliages Ni / Co	Titane, alliage de titane	Alliage Cu Argent Or	Alliage Cu difficile	Alu
Plastique				

D_1	L_1	D_2	L_2	D_{h5}	L	R	CARBURE	TiAIN
$\emptyset < 2.00 - 0/-0.01$								
$\emptyset < 3.00 - 0/-0.02$								
$\emptyset \geq 3.00 - e8$								
0.40	0.40	0.37	1.20	3	38	0.05	958447	958452
0.45	0.45	0.42	1.35	3	38	0.05	958453	958454
0.50	0.50	0.45	1.50	3	38	0.05	958455	958456
0.55	0.55	0.50	1.65	3	38	0.05	958457	958458
0.60	0.60	0.55	1.80	3	38	0.05	958465	958466
0.65	0.65	0.60	1.95	3	38	0.05	958467	958468
0.70	0.70	0.65	2.10	3	38	0.05	958469	958470
0.75	0.75	0.70	2.25	3	38	0.05	958472	958473
0.80	0.80	0.75	2.40	3	38	0.05	958474	958475
0.85	0.85	0.80	2.55	3	38	0.05	958476	958477
0.90	0.90	0.85	2.70	3	38	0.10	958478	958479
0.95	0.95	0.90	2.85	3	38	0.10	958481	958482
1.00	1.00	0.95	3.00	3	38	0.10	958483	958484
1.05	1.05	1.00	3.15	3	38	0.10	958486	958487
1.10	1.10	1.05	3.30	3	38	0.10	958488	958489
1.15	1.15	1.10	3.45	3	38	0.10	958490	958491
1.20	1.20	1.15	3.60	3	38	0.10	958492	958493
1.25	1.25	1.20	3.75	3	38	0.10	958494	958495
1.30	1.30	1.25	3.90	3	38	0.10	958496	958497
1.35	1.35	1.30	4.05	3	38	0.10	958499	958501
1.40	1.40	1.35	4.20	3	38	0.10	958502	958503
1.45	1.45	1.40	4.35	3	38	0.10	958504	958505
1.50	1.50	1.45	4.50	3	38	0.20	958506	958507
1.55	1.55	1.50	4.65	3	38	0.20	958508	958509
1.60	1.60	1.55	4.80	3	38	0.20	958510	958511
1.65	1.65	1.60	4.95	3	38	0.20	958512	958513
1.70	1.70	1.65	5.10	3	38	0.20	958514	958515
1.75	1.75	1.70	5.25	3	38	0.20	958516	958517
1.80	1.80	1.75	5.40	3	38	0.20	958518	958519
1.85	1.85	1.80	5.55	3	38	0.20	958520	958521
1.90	1.90	1.85	5.70	3	38	0.20	958522	958523
1.95	1.95	1.90	5.85	3	38	0.20	958524	958525
2.00	2.00	1.90	6.00	6	50	0.20	958527	958531
2.10	2.10	2.00	6.30	6	50	0.20	958532	958533
2.20	2.20	2.10	6.60	6	50	0.20	958534	958535
2.30	2.30	2.20	6.90	6	50	0.20	958886	958887
2.40	2.40	2.30	7.20	6	50	0.20	958888	958889
2.50	2.50	2.40	7.50	6	50	0.20	958890	958891
3.00	3.00	2.90	9.00	6	50	0.20	958892	958893



DIXI 7070 XIDUR

FRAISES TORIQUES MULTIDENTS
DÉGAGÉES

Z = 4-6



P. 219

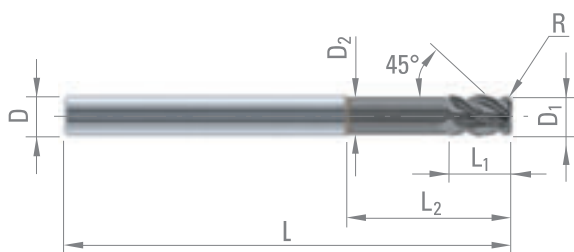

Acier
fort.
allié

Aciers
Fontes
45-65 HRC

Super
alliages
Ni / Co

D _{1 e8}	L ₁	D ₂	L ₂	D _{h5}	L	Z	R	XIDUR
3.00	4.5	2.75	12.0	6	57	4	0.5	56643
4.00	6.0	3.70	13.5	6	57	4	0.5	56644
5.00	7.5	4.60	17.5	6	57	4	0.5	56645
							0.5	56627
6.00	9.0	5.50	24.0	6	66	4	0.8	56646
							1.0	56628
							1.5	56647
							0.5	56634
8.00	10.0	7.50	28.0	8	75	4	1.0	56635
							1.5	56648
							2.0	56649
							0.5	56636
							1.0	56637
10.00	12.0	9.25	30.0	10	75	6	1.5	56650
							2.0	56651
							2.5	56652
							1.0	56653
12.00	12.0	11.00	32.0	12	83	6	1.5	56654
							2.0	56655
							3.0	56656



DIXI 7265

FRAISES À HÉLICES DIFFÉRENTES ET RAYON PARTIEL

Z = 4



P. 190
P. 192

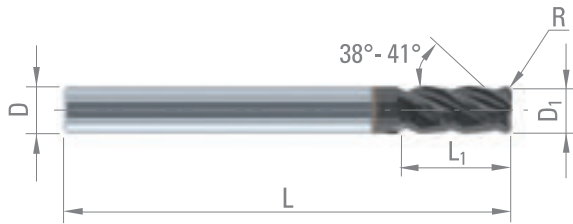

Acier + Pb

Acier faibl. allié

Acier fort. allié

Acier inox aust.

Fontes

Super alliages Ni / Co

Titane, alliage de titane

D ₁ Ø < 3.00 - 0/-0.02 Ø ≥ 3.00 - e8	L ₁	D _{h5}	L	R	CUTINOX
2.00	4.0	3	38	0.5	997936
3.00	8.0	6	57	0.5	997937
4.00	11.0	6	57	0.5	997938
5.00	13.0	6	57	0.5	997939
6.00	13.0	6	57	0.5	997940
				1.0	997941
8.00	19.0	8	63	0.5	997942
				1.0	997943
10.00	22.0	10	72	0.5	997944
				1.0	997945
12.00	26.0	12	83	0.5	997946
				1.0	997947



DIXI 7554

FRAISES TORIQUES HÉLICOÏDALES DÉGAGÉES

Z = 4



P. 194



D₁ ≥ 6

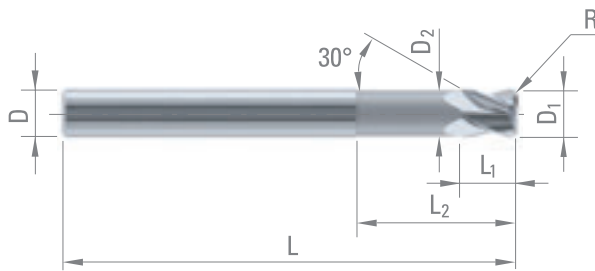

Acier + Pb	Acier faibl. allié	Acier fort. allié	Acier inox aust.	Fontes
Titane, alliage de titane	Alliage Cu Argent Or	Alliage Cu difficile	Alu	Plastique

D ₁	L ₁	D ₂	L ₂	D _{h5}	L	R	CARBURE	TiAIN
∅ < 3.00 - 0/-0.02								
∅ ≥ 3.00 - e8								
2.00	3.0	1.90	10	4	42	0.2	64465	64466
3.00	4.0	2.80	15	6	57	0.2	64467	64468
4.00	5.0	3.80	18	6	57	0.3	64469	64470
6.00	7.0	5.70	20	6	57	0.5	64471	64472
						1.0	64473	64474
8.00	10.0	7.70	30	8	63	0.5	64475	64476
						1.0	64477	64478
10.00	12.0	9.60	35	10	72	0.5	64479	64480
						1.0	64481	64482
12.00	14.0	11.50	40	12	83	0.5	64485	64486
						1.0	64487	64488



DIXI 7552

FRAISES TORIQUES HÉLICOÏDALES DÉGAGÉES

Z = 2



P. 212

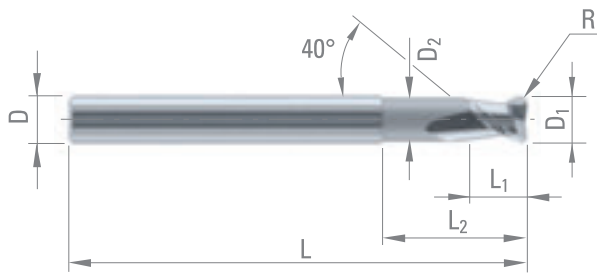

Acier + Pb	Acier faibl. allié	Fontes	Titane, alliage de titane	Alliage Cu Argent Or
Alliage Cu difficile	Alu	Plastique		

D ₁ e8	L ₁	D ₂	L ₂	D _{h5}	L	R	CARBURE	DICUT
3.00	4.0	2.75	10	6	57	0.5	60765	63493
4.00	5.0	3.70	12	6	57	0.5	60766	63494
5.00	6.0	4.60	15	6	57	0.5	60767	63495
6.00	7.0	5.50	18	6	57	1.0	60768	63496
8.00	9.0	7.50	23	8	63	1.0	60769	63497
10.00	11.0	9.25	30	10	75	1.5	60770	63498
12.00	13.0	11.00	35	12	83	1.5	60771	63499
16.00	17.0	15.00	44	16	92	2.0	60772	952918



FRAISES HÉMISPHERIQUES

Z = 2

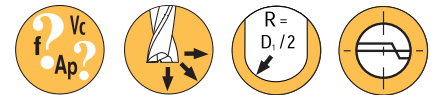

P. 172

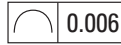
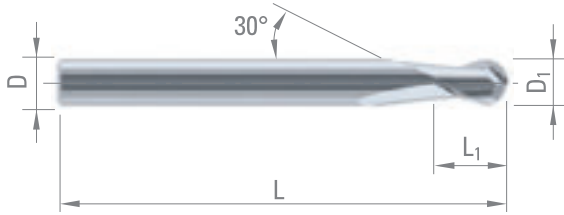

Acier + Pb	Acier faibl. allié	Acier fort. allié	Acier inox aust.	Fontes
Super alliages Ni / Co	Titane, alliage de titane	Alliage Cu Argent Or	Alliage Cu difficile	Alu
Graphite	Plastique			

D ₁	L ₁	D _{h5}	L	CARBURE TiAIN	DICUT	DIAMANT
----------------	----------------	-----------------	---	---------------	-------	---------

Ø < 0.30 - 0/-0.01
 Ø < 3.00 - 0/-0.02
 Ø ≥ 3.00 - e8

0.06	0.12	3	38	959060			
0.08	0.16	3	38	959059			
0.10	0.20	3	38	959058			
0.15	0.30	3	38	954665			
0.20	0.30	3	38	952795	952796	952797	952799
0.25	0.40	3	38	952800	952801	952802	952803
0.30	0.50	3	38	952804	952805	952806	58852
0.40	0.60	3	38	952807	952808	952809	952810
0.50	0.80	3	38	952811	952812	952813	952814
0.60	0.90	3	38	952815	952816	952817	952818
0.70	1.10	3	38	952819	952820	952821	950363
0.80	1.20	3	38	952822	952823	950703	950364
0.90	1.40	3	38	952825	952826	952824	950365
1.00	1.50	3	38	952827	952828	952829	952830
1.10	1.70	3	38	952832	952833	952831	950366
1.20	1.80	3	38	952835	952836	952834	950367
1.30	1.90	3	38	952838	952839	952837	950368
1.40	2.10	3	38	952841	952842	952840	950369
1.50	2.30	3	38	952843	952846	952845	952844
1.60	2.50	3	38	55539	955784	956236	956237
1.70	2.50	3	38	60112	956238	956239	956240
1.80	2.75	3	38	48747	956241	956242	956243
1.90	2.75	3	38	57714	956244	956245	956246
2.00	3.00	3	38	44604	56136	64280	59783
2.10	3.00	3	38	55540	956247	956248	956249
2.20	3.50	3	38	48457	956250	956251	956253
2.30	3.50	3	38	66547	62925	956254	956255
2.40	3.50	3	38	60788	62926	956256	956257
2.50	4.00	3	38	44605	56137	64288	60221
3.00	5.00	3	38	43115	56138	63876	59988
3.50	6.00	4	50	44607	56139	64289	950370
4.00	6.00	4	50	34120	56140	64290	59784
4.50	7.00	5	50	44609	56141	64291	950371
5.00	8.00	5	50	34748	36172	64292	60222
5.50	9.00	6	57	44611	56172	64293	950372
6.00	9.00	6	57	34749	56179	63923	46800
7.00	11.00	7	60	34740	56176	64294	66878
8.00	12.00	8	63	43389	36174	64295	58860
10.00	15.00	10	72	42940	56177	63924	36175
12.00	18.00	12	73	32387	56173	64296	60223
14.00	21.00	14	75	32388	56174		
16.00	24.00	16	82	32136	56175		
20.00	30.00	20	104	35736	56183		

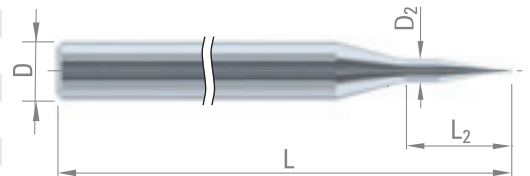

Pour **D₁ ≤ 0.15:**
 D₂ = 1.20
 L₂ = 5.30

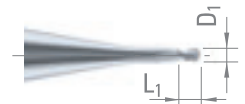

FRAISES HÉMISPHERIQUES

Z = 2

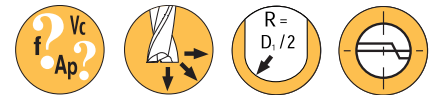

P. 178

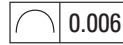
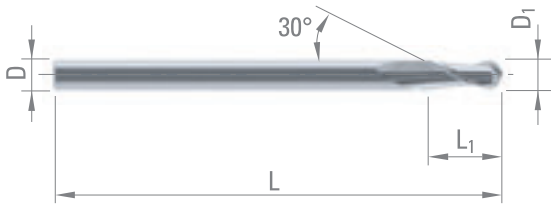

Acier + Pb	Acier faibl. allié	Acier fort. allié	Acier inox aust.	Fontes
Super alliages Ni / Co	Titane, alliage de titane	Alliage Cu Argent Or	Alliage Cu difficile	Alu
Graphite	Plastique			

D _{1 e8}	L ₁	D _{h5}	L	CARBURE	TiAIN	DIAMANT
2.00	10	2	61	41974	56238	60224
3.00	10	3	61	39512	56239	60225
4.00	12	4	75	38639	56240	60226
5.00	14	5	86	38942	56241	60227
6.00	16	6	93	38623	56242	60228
8.00	20	8	100	38640	56243	60229
10.00	24	10	100	38641	56244	58790
12.00	28	12	110	40728	56245	60230
16.00	36	16	120	40730	56247	
20.00	45	20	150	40732	56248	



FRAISES HÉMISPHERIQUES
DÉGAGÉES

Z = 2



P. 176

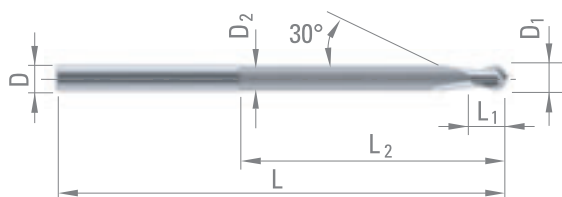

0.006

Acier + Pb	Acier faibl. allié	Acier fort. allié	Acier inox aust.	Fontes
Super alliages Ni / Co	Titane, alliage de titane	Alliage Cu Argent Or	Alliage Cu difficile	Alu
Graphite	Plastique			

D ₁	L ₁	D ₂	L ₂	D _{h5}	L	CARBURE	TAIN	DICUT	DIAMANT
0.20	0.5	0.18	1.0	4	55	64714	64719	64724	64729
0.30	0.6	0.27	1.5	4	55	64715	64720	64725	64730
0.40	0.8	0.37	2.0	4	55	64716	64721	64726	64731
0.50	1.0	0.45	3.0	4	55	64542	64556	64572	64584
0.60	1.6	0.55	4.0	4	55	64717	64722	64727	64732
0.80	1.8	0.75	5.0	4	55	64718	64723	64728	64733
1.00	2.0	0.95	6.0	4	55	64544	64557	64573	64585
1.50	2.5	1.45	9.0	4	55	64546	64558	64574	64586
2.00	3.0	1.90	12.0	4	55	64547	64559	64575	64587
2.50	4.0	2.40	12.0	4	55	64548	64560	64576	64588
3.00	5.0	2.80	12.0	6	57	64549	64561	64577	64589
4.00	6.0	3.80	15.0	6	57	64550	64562	64578	64590
5.00	7.0	4.80	15.0	6	57	64551	64567	64579	64591
6.00	8.0	5.70	15.0	6	57	64552	64568	64580	64592
8.00	10.0	7.70	25.0	8	63	64553	64569	64581	64593
10.00	12.0	9.60	30.0	10	72	64554	64570	64582	64594
12.00	14.0	11.60	40.0	12	83	64555	64571	64583	64595

Ø < 3.00 - 0/-0.02
Ø ≥ 3.00 - e8



DIXI 7045 - 7047-D

FRAISES HÉMISPHERIQUES DÉGAGÉES

Z = 2



P. 176

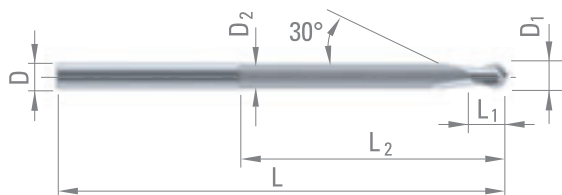

0.006

Acier + Pb	Acier faibl. allié	Acier fort. allié	Acier inox aust.	Fontes
Super alliages Ni / Co	Titane, alliage de titane	Alliage Cu Argent Or	Alliage Cu difficile	Alu
Graphite	Plastique			

D ₁	L ₁	D ₂	D _{h5}	L	L ₂	DIXI	CARBURE	TAIN	DICUT	DIAMANT	
Ø < 3.00 - 0/-0.02 Ø ≥ 3.00 - e8	0.20	0.5	0.18	4	62	7045	64694	64699	64704	64709	
						7047-8D	979531	979555	979576	979595	
						2.0	7047-10D	64735	64742	64750	64755
						2.4	7047-12D	979613	979626	979639	979664
						3.0	7047-15D	979711	979722	979732	979744
						3.6	7047-18D	979756	979768	979779	979790
						1.5	7045	64695	64700	64705	64710
						2.4	7047-8D	979534	979558	979578	979596
						3.0	7047-10D	64738	64743	64751	64756
						3.6	7047-12D	979614	979627	979640	979652
						4.5	7047-15D	979712	979724	979733	979745
						5.4	7047-18D	979757	979769	979780	979791
						2.0	7045	64696	64701	64706	64711
						3.2	7047-8D	979535	979559	979579	979597
						4.0	7047-10D	64739	64744	64752	64757
						4.8	7047-12D	979615	979628	979641	979653
						6.0	7047-15D	979713	979723	979734	979746
						7.2	7047-18D	979758	979770	979781	979792
						3.0	7045	64491	64503	64515	64527
						4.0	7047-8D	979536	979560	979580	979598
						5.0	7047-10D	64596	64608	64623	64635
						6.0	7047-12D	979616	979629	979642	979654
						7.5	7047-15D	979714	979725	979735	979747
						9.0	7047-18D	979759	979771	979782	979793
						4.0	7045	64697	64702	64707	64712
						4.8	7047-8D	979537	979561	979581	979599
						6.0	7047-10D	64740	64745	64753	64758
						7.2	7047-12D	979617	979630	979643	979655
						9.0	7047-15D	979715	979726	979736	979748
						10.8	7047-18D	979760	979772	979783	979794
						5.0	7045	64698	64703	64708	64713
						6.4	7047-8D	979538	979562	979582	979600
						8.0	7047-10D	64741	64746	64754	64759
						9.6	7047-12D	979618	979631	979644	979656
						12.0	7047-15D	979716	979727	979737	979749
						14.4	7047-18D	979761	979773	979784	979795
						6.0	7045	64492	64504	64516	64528
						8.0	7047-8D	979540	979563	979583	979601
						10.0	7047-10D	64597	64609	64624	64636
						12.0	7047-12D	979619	954101	979314	979657
						15.0	7047-15D	975225	979728	979738	979750
						18.0	7047-18D	979522	979774	979785	979523
						9.0	7045	64493	64505	64517	64529
						12.0	7047-8D	979541	979565	979585	979602
						15.0	7047-10D	64598	64610	64625	64637
						18.0	7047-12D	979620	979632	979645	979658
						22.5	7047-15D	979717	979729	979739	979751
						27.0	7047-18D	979763	979775	979786	979799



DIXI 7045 - 7047-D



P. 176

Acier + Pb	Acier faibl. allié	Acier fort. allié	Acier inox aust.	Fontes
Super alliages Ni / Co	Titane, alliage de titane	Alliage Cu Argent Or	Alliage Cu difficile	Alu
Graphite	Plastique			

D ₁	L ₁	D ₂	D _{h5}	L	L ₂	DIXI	CARBURE	TAIN	DICUT	DIAMANT	
Ø < 3.00 - 0/-0.02 Ø ≥ 3.00 - e8	2.00	3.0	1.90	4	75	12.0	7045	64494	64506	64518	64530
						16.0	7047-8D	979542	979566	979588	979603
						20.0	7047-10D	64599	64611	64626	64638
						24.0	7047-12D	979621	979633	979646	979659
						30.0	7047-15D	972993	954105	979740	979752
						36.0	7047-18D	979765	979776	979787	979796
						12.0	7045	64495	64507	64519	64531
						20.0	7047-8D	979544	979567	979589	979604
2.50	4.0	2.40	4	75	25.0	7047-10D	64600	64612	64627	64639	
					30.0	7047-12D	979622	979635	979648	979660	
					37.5	7047-15D	979719	979718	979741	979753	
					45.0	7047-18D	979766	979777	979788	979797	
					12.0	7045	64496	64508	64520	64532	
3.00	5.0	2.80	6	102	24.0	7047-8D	979545	979568	979590	979605	
					30.0	7047-10D	64601	64613	64628	64640	
					36.0	7047-12D	979623	979636	979649	979661	
					45.0	7047-15D	979720	979730	979742	979754	
					54.0	7047-18D	979767	979778	979789	979798	
4.00	6.0	3.80	6	102	15.0	7045	64497	64509	64521	64533	
					32.0	7047-8D	979547	979569	979591	979607	
					40.0	7047-10D	64602	64614	64629	64641	
					48.0	7047-12D	979624	979637	979650	979662	
					60.0	7047-15D	979721	979731	979743	979755	
5.00	7.0	4.80	6	102	15.0	7045	64498	64510	64522	64534	
					40.0	7047-8D	979549	979570	979592	979608	
					50.0	7047-10D	64603	64615	64630	64642	
					60.0	7047-12D	979625	979638	979651	979663	
6.00	8.0	5.70	6	102	15.0	7045	64499	64511	64523	64536	
					48.0	7047-8D	979550	979571	979593	979609	
					60.0	7047-10D	64604	64616	64631	64643	
8.00	10.0	7.70	8	117	25.0	7045	64500	64512	64524	64537	
					64.0	7047-8D	979551	979572	979594	979610	
					80.0	7047-10D	64605	64617	64632	64644	
10.00	12.0	9.60	10	133	30.0	7045	64501	64513	64525	64538	
					80.0	7047-8D	979552	979573	979586	979611	
					90.0	7047-10D	64606	64618	64633	64645	
12.00	14.0	11.60	12	151	40.0	7045	64502	64514	64526	64539	
					96.0	7047-8D	979553	979574	979587	979612	
					110.0	7047-10D	64607	64619	64634	64646	

DIXI 7045 $L_2 = 2.5-6 \times D_1$

DIXI 7047-8D $L_2 = 8 \times D_1$

DIXI 7047-10D $L_2 = 10 \times D_1$

DIXI 7047-12D $L_2 = 12 \times D_1$

DIXI 7047-15D $L_2 = 15 \times D_1$

DIXI 7047-18D $L_2 = 18 \times D_1$



DIXI 7532 XIDUR

FRAISES HÉMISPHERIQUES

Z = 2



P. 216

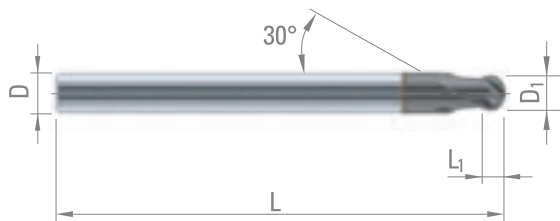

0.006

Acier fort. allié

Aciers Fontes 45-65 HRC

Super alliages Ni / Co

D ₁	L ₁	D _{h5}	L	XIDUR
0.20	0.2	4	50	973380
0.30	0.3	4	50	972176
0.40	0.4	4	50	973379
0.50	0.5	4	50	973378
0.60	0.6	4	50	973377
0.70	0.7	4	50	972177
0.80	0.8	4	50	973376
0.90	0.8	4	50	973375
1.00	0.8	4	50	67253
1.50	1.2	4	50	67254
2.00	1.6	4	50	67257
3.00	2.4	6	57	67258
4.00	3.2	6	66	67259
5.00	4.0	6	66	67260
6.00	4.8	6	66	67261
8.00	6.4	8	75	67262
10.00	8.0	10	90	67255



DIXI 7532-D XIDUR

FRAISES HÉMISPHERIQUES

Z = 2



P. 216

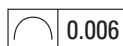
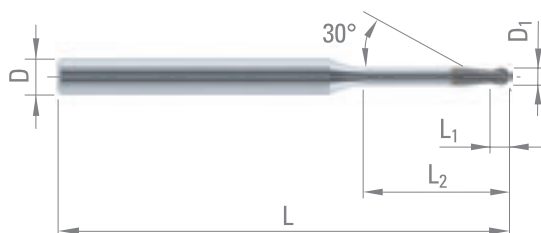

Acier fort. allié

Aciers Fontes 45-65 HRC

Super alliages Ni / Co

D ₁	L ₁	D _{h5}	L	L ₂	DIXI	XIDUR
0.20	0.2	4	50	0.6	7532-3D	978593
				1.0	7532-5D	979083
				1.6	7532-8D	979102
0.30	0.3	4	50	0.9	7532-3D	979058
				1.5	7532-5D	979084
				2.4	7532-8D	979103
0.40	0.4	4	50	1.2	7532-3D	979059
				2.0	7532-5D	979085
				3.2	7532-8D	979104
				4.0	7532-10D	979116
0.50	0.5	4	50	1.5	7532-3D	979060
				2.5	7532-5D	979086
				4.0	7532-8D	979105
				5.0	7532-10D	979117
				6.0	7532-12D	979136
0.60	0.6	4	50	1.8	7532-3D	979061
				3.0	7532-5D	979087
				4.8	7532-8D	979106
				6.0	7532-10D	979118
				7.2	7532-12D	979137
				9.0	7532-15D	979144
				2.1	7532-3D	979062
0.70	0.7	4	50	3.5	7532-5D	979088
				5.6	7532-8D	979107
				7.0	7532-10D	979119
				8.4	7532-12D	979138
				10.5	7532-15D	979145
				2.4	7532-3D	979063
0.80	0.8	4	50	4.0	7532-5D	979089
				6.4	7532-8D	979108
				8.0	7532-10D	979120
				9.6	7532-12D	979139
				12.0	7532-15D	979146
				2.7	7532-3D	979064
0.90	0.8	4	50	4.5	7532-5D	979091
				7.2	7532-8D	979109
				9.0	7532-10D	979121
				10.8	7532-12D	979140
				13.5	7532-15D	979147
				3.0	7532-3D	979065
1.00	0.8	4	50	5.0	7532-5D	979092
				8.0	7532-8D	979111
				10.0	7532-10D	979122
				12.0	7532-12D	979141
				15.0	7532-15D	979148
				4.5	7532-3D	979066
1.50	1.2	4	50	7.5	7532-5D	979093
				12.0	7532-8D	979112
				15.0	7532-10D	979123
				18.0	7532-12D	979142
				22.5	7532-15D	979149

DIXI 7532-3D

$$L_2 = 3 \times D_1$$

DIXI 7532-5D

$$L_2 = 5 \times D_1$$

DIXI 7532-8D

$$L_2 = 8 \times D_1$$

DIXI 7532-10D

$$L_2 = 10 \times D_1$$

DIXI 7532-12D

$$L_2 = 12 \times D_1$$

DIXI 7532-15D

$$L_2 = 15 \times D_1$$



DIXI 7532-D XIDUR



P. 216

D ₁	L ₁	D _{h5}	L	L ₂	X	XIDUR
Ø < 3.00 - 0/-0.02						
Ø ≥ 3.00 - e8						
2.00	1.6	4	50	6.0	7532-3D	979067
				10.0	7532-5D	979094
				16.0	7532-8D	979113
				20.0	7532-10D	979124
				24.0	7532-12D	979143
				30.0	7532-15D	979150
3.00	2.4	6	57	9.0	7532-3D	979068
				15.0	7532-5D	979095
				24.0	7532-8D	979114
				30.0	7532-10D	979125
4.00	3.2	6	66	12.0	7532-3D	979069
				20.0	7532-5D	979096
				32.0	7532-8D	979115
5.00	4.0	6	66	15.0	7532-3D	979070
				25.0	7532-5D	979097
6.00	4.8	6	66	18.0	7532-3D	979071
				30.0	7532-5D	979098
8.00	6.4	8	66	24.0	7532-3D	979072
				40.0	7532-5D	979099
10.00	8.0	10	66	30.0	7532-3D	979073
				50.0	7532-5D	979100

Acier fort. allié

Aciers Fontes 45-65 HRC

Super alliages Ni / Co

DIXI 7532-3D $L_2 = 3 \times D_1$

DIXI 7532-5D $L_2 = 5 \times D_1$

DIXI 7532-8D $L_2 = 8 \times D_1$

DIXI 7532-10D $L_2 = 10 \times D_1$

DIXI 7532-12D $L_2 = 12 \times D_1$

DIXI 7532-15D $L_2 = 15 \times D_1$

DIXI 7542 XIDUR

FRAISES HÉMISPHERIQUES DÉGAGÉES

Z = 2



P. 217

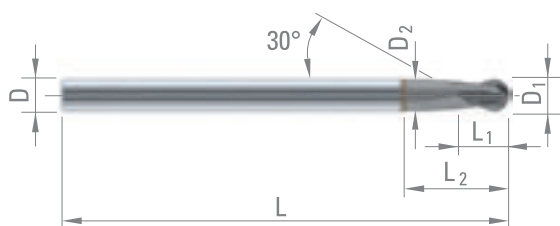

0.006

Acier fort. allié

Acier Fontes 45-65 HRC

Super alliages Ni / Co

D ₁	L ₁	D ₂	L ₂	D _{h5}	L	XIDUR
Ø < 3.00 - 0/-0.02						
Ø ≥ 3.00 - e8						
1.00	2.0	0.90	3.2	6	66	61355
1.50	3.0	1.40	4.7	6	66	61356
2.00	3.0	1.85	6.2	6	66	61357
3.00	5.0	2.85	9.2	6	66	61358
4.00	6.0	3.80	12.5	6	80	61359
5.00	7.0	4.70	15.5	6	80	61360
6.00	9.0	5.70	19.0	6	80	61361
8.00	12.0	7.50	25.0	8	90	61362
10.00	15.0	9.50	31.0	10	110	61363
12.00	18.0	11.50	37.0	12	120	61364



DIXI 7033

FRAISES HÉMISPHERIQUES

Z = 3



P. 174

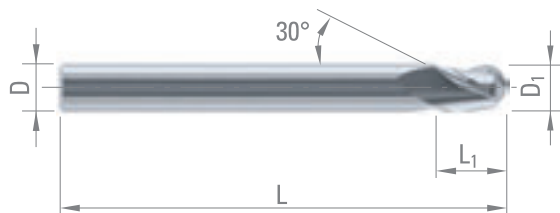

Acier + Pb	Acier faibl. allié	Acier fort. allié	Acier inox aust.	Fontes
Super alliages Ni / Co	Titane, alliage de titane	Alliage Cu Argent Or	Alu	Plastique

D ₁	L ₁	D _{h5}	L	CARBURE	TiAIN
1.00	2.0	3	38	45950	56154
1.50	2.5	3	38	45230	56155
2.00	3.0	3	38	45231	56156
2.50	4.0	3	38	45232	56157
3.00	5.0	3	38	43637	56158
4.00	6.0	4	50	43638	56159
5.00	8.0	5	50	43639	56162
6.00	9.0	6	57	42993	56163
8.00	12.0	8	63	32969	56165
10.00	15.0	10	72	32970	56166
12.00	18.0	12	73	32971	56167

DIXI 7034

FRAISES HÉMISPHERIQUES

Z = 4



P. 174

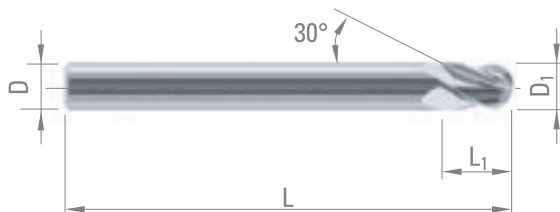

Acier + Pb	Acier faibl. allié	Acier fort. allié	Acier inox aust.	Fontes
Super alliages Ni / Co	Titane, alliage de titane	Alliage Cu Argent Or	Alliage Cu difficile	Alu
Plastique				

D _{1 e8}	L ₁	D _{h5}	L	CARBURE	TiAIN
6.00	9	6	57	43640	56142
8.00	12	8	63	43641	56143
10.00	15	10	72	32974	56144
12.00	18	12	73	32975	56149
14.00	21	14	75	32976	
16.00	24	16	82	42827	56151
20.00	30	20	104	35740	



DIXI 72420

FRAISES EN BOUT
AVEC COUPE AU CENTRE
ET TROUS DE LUBRICATION

Z = 1-2



P. 380



$D_1 \geq \varnothing 6$

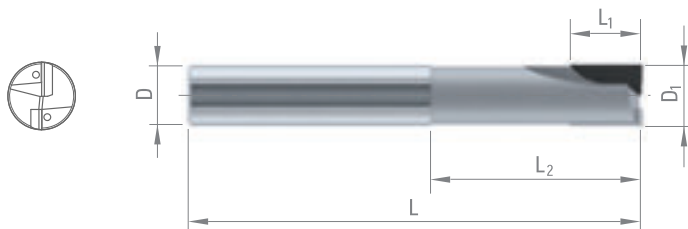

- Alliage Cu
Argent
Or
- Alliage
Cu
difficile
- Alu
- Graphite
- Carbure
Céramique
verte
- Plastique
- Fibre de
carbone

D_{1h10}	L_1	L_2	D_{h5}	L	Z	PCD	CVD
1.00	2.0	-	6	42	1	979179	
1.50	3.0	-	6	42	1	977382	
2.00	3.0	6	6	42	1	66785	
2.00 >	3.0	20	6	75	1	970175	
3.00	4.0	6	6	42	1	67540	301958
3.00 >	4.0	6	6	42	2		305549
3.00 >	4.0	15	6	75	2	970176	
3.00 >	4.0	20	6	75	2	970177	
4.00	4.0	8	6	50	1	957593	
4.00 >	6.5	10	6	50	1	67541	301959
4.00 >	6.5	15	6	75	2	970178	
4.00 >	6.5	25	6	75	2	970179	
5.00	5.0	10	6	50	2	957595	
5.00 >	6.5	10	6	50	2	53153	
5.00 >	6.5	35	6	75	2	970166	301960
6.00	6.0	12	6	57	2	976391	301961
6.00 >	8.0	34	6	75	2	976392	
6.00 >	8.0	50	6	100	2	976393	
7.00	8.0	34	8	75	2	976394	301962
8.00	7.0	14	8	63	2	976395	301963
8.00 >	10.0	34	8	75	2	976396	
8.00 >	10.0	50	8	100	2	976397	
8.00 >	10.0	75	8	125	2	976398	
9.00	10.0	35	10	75	2	976399	
10.00	8.0	16	10	75	2	976410	301965
10.00 >	12.0	35	10	75	2	976411	
10.00 >	12.0	75	10	125	2	976412	
11.00	12.0	38	12	83	2	976413	
12.00	10.0	20	12	83	2	976414	301966
12.00 >	12.0	38	12	83	2	976415	
12.00 >	12.0	75	12	125	2	976416	
14.00	12.0	24	14	83	2	976417	
14.00 >	12.0	38	14	83	2	976418	
14.00 >	12.0	75	14	125	2	976419	
16.00	14.0	28	16	92	2	976420	
16.00 >	14.0	42	16	92	2	976421	
16.00 >	14.0	75	16	125	2	976422	
20.00	18.0	36	20	104	2	976423	
20.00 >	18.0	50	20	125	2	976424	

Sur demande

CBN ▲

Aciers
Fontes
45-65 HRC

Fontes

Sur demande

Sur demande



DIXI 70520 PCD

FRAISES TORIQUES
AVEC COUPE AU CENTRE
ET TROUS DE LUBRICATION

Z = 1-2

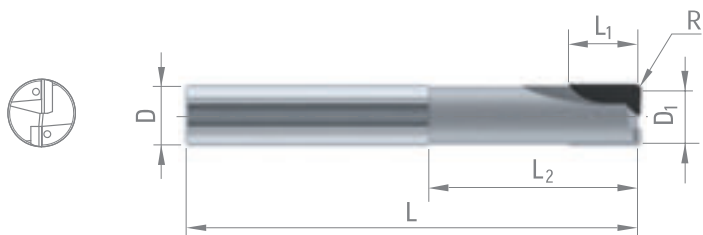
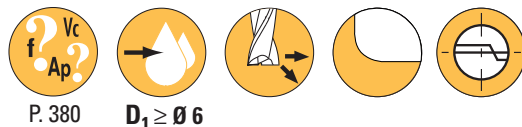

Alliage Cu Argent Or	Alliage Cu difficile	Alu	Graphite	Carbure Céramique verte
Plastique	Fibre de carbone			

D _{1h10}	L ₁	L ₂	D _{h5}	L	R	Z	PCD
1.00	2.0	-	6	42	0.1	1	984384
2.00	3.0	6	6	42	0.1	1	967923
2.00 >	3.0	6	6	42	0.2	1	973528
3.00	4.0	15	6	75	0.1	2	987438
3.00 >	4.0	15	6	75	0.3	2	305810
4.00	4.0	8	6	50	0.1	1	967925
4.00 >	6.5	10	6	50	0.5	2	971465
4.00 >	6.5	15	6	75	0.1	2	305811
4.00 >	6.5	15	6	75	0.5	2	302378
5.00	5.0	10	6	50	0.1	2	305812
5.00 >	5.0	10	6	50	0.5	2	975839
6.00	6.0	12	6	57	0.1	2	967926
6.00 >	6.0	12	6	57	0.5	2	968992
6.00 >	8.0	34	6	75	0.1	2	995208
6.00 >	8.0	34	6	75	0.5	2	974475
6.00 >	8.0	34	6	75	1.0	2	974476
8.00	7.0	14	8	63	0.1	2	967927
8.00 >	10.0	34	8	75	0.5	2	974477
8.00 >	10.0	34	8	75	1.0	2	974478
10.00	12.0	35	10	75	0.1	2	953153
10.00 >	12.0	35	10	75	0.5	2	974479
10.00 >	12.0	35	10	75	1.0	2	974480
10.00 >	12.0	75	10	125	0.5	2	974482
10.00 >	12.0	75	10	125	1.0	2	974481
12.00	10.0	20	12	83	0.1	2	984083
12.00 >	12.0	38	12	83	0.5	2	974483
12.00 >	12.0	38	12	83	1.0	2	974484
12.00 >	12.0	75	12	125	0.5	2	974485
12.00 >	12.0	75	12	125	1.0	2	974486
14.00	12.0	24	14	83	0.1	2	305814
14.00 >	12.0	24	14	83	0.5	2	305816
14.00 >	12.0	24	14	83	1.0	2	305817
16.00	14.0	28	16	92	0.1	2	993052
16.00 >	14.0	42	16	92	0.5	2	305818
16.00 >	14.0	42	16	92	1.0	2	305139
20.00	18.0	36	20	104	0.1	2	987718
20.00 >	18.0	36	20	104	0.5	2	305919
20.00 >	18.0	36	20	104	1.0	2	305820

CVD ■

Alliage Cu Argent Or	Alliage Cu difficile	Alu	Graphite
Carbure Céramique verte	Plastique	Fibre de carbone	

Sur demande

CBN ▲

Aciers Fontes 45-65 HRC	Fontes
-------------------------------	--------



DIXI 70600 PCD

FRAISES À DENTURE DROITE
AVEC COUPE AU CENTRE

Z = 1

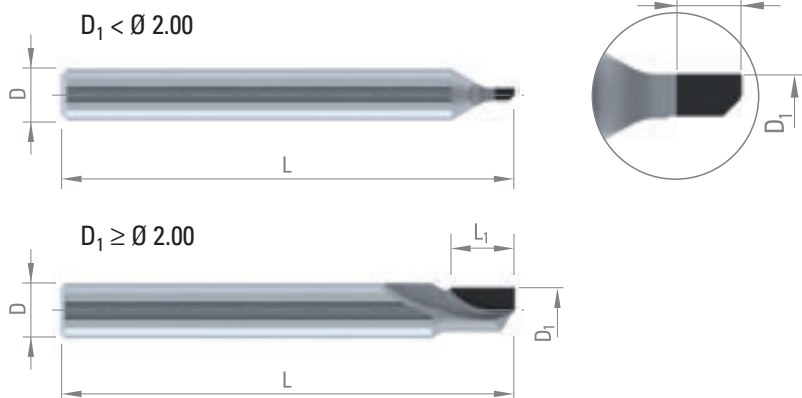

P. 380

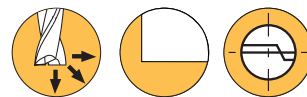

Alliage Cu
Argent
Or

Alliage
Cu
difficile

Alu

Graphite

Carbure
Céramique
verte

Plastique

Fibre de
carbone

D_{1h10}	L_1	D_{h5}	L	PCD
1.00	2.0	6	35	302387
2.00	3.0	6	35	302388
3.00	4.0	6	42	302389
4.00	6.5	6	42	302390
5.00	6.5	6	50	302391
6.00	8.0	6	50	302393

DIXI 70600 DIA

FRAISES EN BOUT
DIAMANT MONOCRISTALLIN
AVEC COUPE AU CENTRE

Z = 1

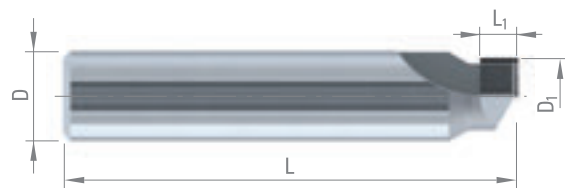

P. 380



Alliage Cu
Argent
Or

Alliage
Cu
difficile

Alu

D_1	L_1	D_{h5}	L	DIA
3.00	2.5	6	30	302394
4.00	2.5	6	30	302395
5.00	2.5	6	30	302396
6.00	2.5	6	30	302397

DIXI 72310 DIA

MICRO-FRAISES
DIAMANT MONOCRISTALLIN

Z = 1

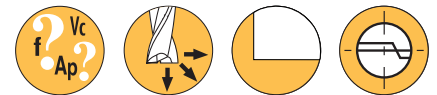

P. 380

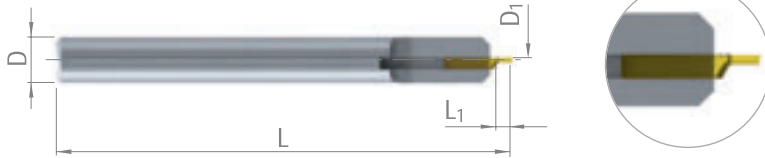

- Alliage Cu
Argent
Or
- Alliage
Cu
difficile
- Alu
- Plastique

D ₁	L ₁	D _{h5}	L	DIA
0.30	0.6	3	30	953423
0.40	0.8	3	30	953424
0.50	1.0	3	30	953425
0.60	1.2	3	30	953426
0.70	1.4	3	30	953427
0.80	1.6	3	30	953428
0.90	1.8	3	30	953429
1.00	2.5	3	30	953430
1.10	2.5	3	30	953431
1.20	2.5	3	30	953432
1.30	2.5	3	30	953433
1.40	2.5	3	30	953434
1.50	2.5	3	30	953435
1.60	2.5	3	30	953436
1.70	2.5	3	30	953437
1.80	2.5	3	30	953438
1.90	2.5	3	30	953439
2.00	2.5	6	30	953440

Corps acier

Lors de la commande, il conviendra d'indiquer la matière à usiner (non-ferreuse).



DIXI 72421 DIA

FRAISES EN BOUT
DIAMANT MONOCRISTALLIN
POUR ACRYLIQUE

Z = 1



P. 380

Plastique

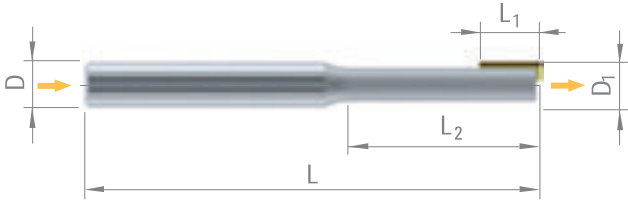

D_1	L_1	L_2	D_{h5}	L	DIA
6.00	4	25	6	57	970120
6.00	6	25	6	57	970122
6.00	8	25	6	57	974360
8.00	4	25	8	63	970126
8.00	6	25	8	63	970128
8.00	8	25	8	63	970129
10.00	4	25	10	75	974317
10.00	6	25	10	75	974318
10.00	8	25	10	75	974319
12.00	4	25	12	83	974321
12.00	6	25	12	83	974322
12.00	8	25	12	83	974323

DIXI 70320 PCD

FRAISES HÉMISPHERIQUES AVEC TROUS DE LUBRICATION

Z = 1-2



P. 380



$D_1 \geq \emptyset 6$

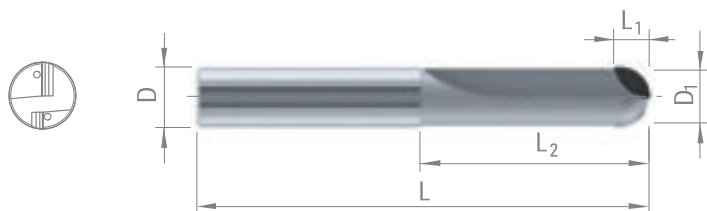

Alliage Cu Argent Or	Alliage Cu difficile	Alu	Graphite	Plastique
----------------------------	----------------------------	-----	----------	-----------

$D_{1\ h10}$	L_1	L_2	D	L	Z	PCD
2.00	2.0	6.0	6	42	1	953442
2.00	2.0	25.0	6	75	1	970874
3.00	2.5	6.0	6	42	1	953443
3.00	2.5	25.0	6	75	1	970875
3.00	2.5	25.0	6	75	2	970876
4.00	3.0	8.0	6	50	1	959468
4.00	3.0	10.0	6	50	1	953444
4.00	3.0	10.0	6	50	2	970877
4.00	3.0	25.0	6	75	2	970878
4.00	3.0	35.0	6	75	2	981585
5.00	4.0	10.0	6	50	2	953445
5.00	4.0	25.0	6	75	2	970883
6.00	4.0	12.0	6	57	2	976433
6.00	4.0	34.0	6	75	2	976434
6.00	4.0	50.0	6	100	2	976435
8.00	5.0	14.0	8	63	2	976436
8.00	5.0	34.0	8	75	2	976437
8.00	5.0	75.0	8	125	2	976438
10.00	6.0	16.0	10	72	2	976439
10.00	6.0	35.0	10	75	2	976440
10.00	6.0	75.0	10	125	2	976441
12.00	7.0	20.0	12	83	2	976442
12.00	7.0	38.0	12	83	2	976443
12.00	7.0	75.0	12	125	2	976444
14.00	8.0	24.0	16	83	2	305821
16.00	9.0	28.0	16	92	2	300800
20.00	11.0	36.0	20	104	2	305822

CVD

Alliage Cu Argent Or	Alliage Cu difficile	Alu	Graphite
Carbure Céramique verte	Plastique	Fibre de carbone	

Sur demande

CBN

Aciers Fontes 45-65 HRC	Fontes
-------------------------------	--------

DIXI 76230 DIA

FRAISES À ANGLER
DIAMANT MONOCRISTALLIN

Z = 1

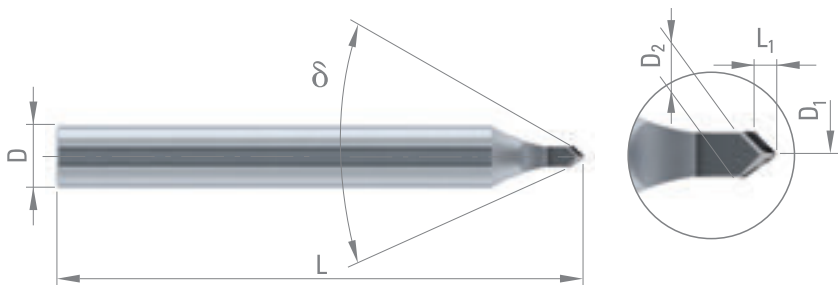
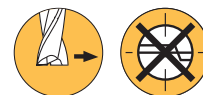

Alliage Cu Argent Or	Alliage Cu difficile	Alu	Plastique
----------------------------	----------------------------	-----	-----------

D ₁	L ₁	D ₂	δ	D _{h5}	L	DIA
* 0.10	1.40	3	60°	6	50	302596
* 0.10	0.80	3	90°	6	50	302595
* 0.30	2.80	2	30°	6	50	978382
* 0.30	1.30	3	60°	6	50	978381
* 0.30	0.70	3	90°	6	50	977871

* non coupant

DIXI 7623

FRAISES À ANGLER

Z = 3



P. 184

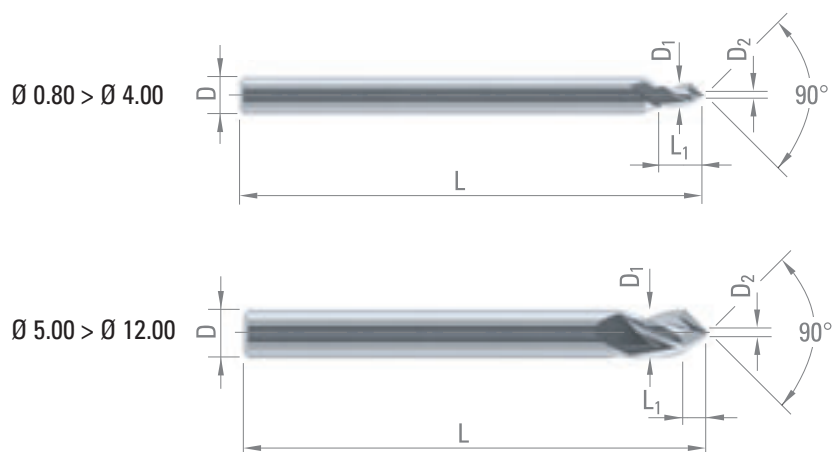

D₁ e8
Ø < 2.00 - 0/-0.01
Ø < 3.00 - 0/-0.02
Ø < 5.00 - e8

L₁ D₂ ± 0.05 D_{h5} L CARBURE TiAlN

0.80	1.5	0.08	3	38	956868	956870
1.00	2.0	0.10	3	38	956867	956869
2.00	3.0	0.20	3	38	956865	956866
3.00	5.0	0.30	3	38	956861	956862
4.00	6.0	0.40	4	50	956863	956864

D ₁ h5	L ₁	D ₂ ± 0.05	D _{h5}	L	CARBURE	TiAlN
5.00	2.25	0.50	5	50	49019	952294
6.00	2.7	0.60	6	57	49020	63603
8.00	3.6	0.80	8	63	49021	950927
10.00	4.5	1.00	10	72	49022	63604
12.00	5.4	1.20	12	73	49023	952295

Acier + Pb	Acier faibl. allié	Acier fort. allié	Acier inox aust.	Fontes
Super alliages Ni / Co	Titane, alliage de titane	Alliage Cu Argent Or	Alliage Cu difficile	Alu
Plastique				



DIXI 7624

FRAISES À ANGLER BICONIQUE

Z = 1-4



P. 184

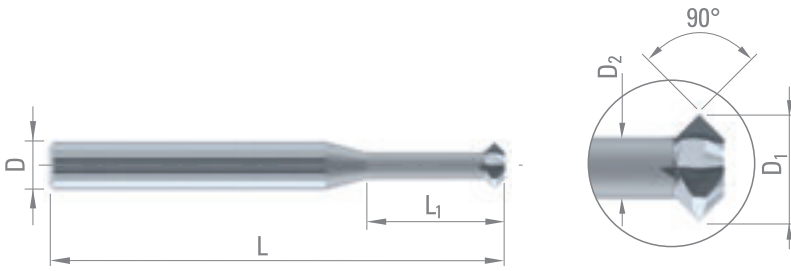

Acier + Pb	Acier faibl. allié	Acier fort. allié	Acier inox aust.	Fontes
Super alliages Ni / Co	Titane, alliage de titane	Alliage Cu Argent Or	Alliage Cu difficile	Alu
Plastique				

D ₁	L ₁	D ₂	ch	D _{h5}	L	Z	CARBURE
0.20	0.4	0.12	0.04	3	38	1	997990
0.25	0.5	0.15	0.05	3	38	1	997991
0.30	0.6	0.18	0.06	3	38	1	997992
0.40	0.8	0.24	0.08	3	38	1	997993
0.50	1.0	0.30	0.10	3	38	1	997994
0.60	1.2	0.36	0.12	3	38	3	997995
0.70	1.4	0.42	0.14	3	38	3	997996
0.80	1.6	0.48	0.16	3	38	3	997997
0.90	1.8	0.54	0.18	3	38	3	997998
1.00	2.0	0.60	0.20	3	38	3	997999
1.20	2.4	0.70	0.25	3	38	4	998000
1.30	2.6	0.70	0.30	3	38	4	998001
1.80	5.4	1.00	0.40	3	38	4	998002
2.80	8.4	1.60	0.60	3	38	4	998003
3.70	11.1	2.10	0.80	6	57	4	998004
5.70	17.1	3.30	1.20	6	57	4	998005

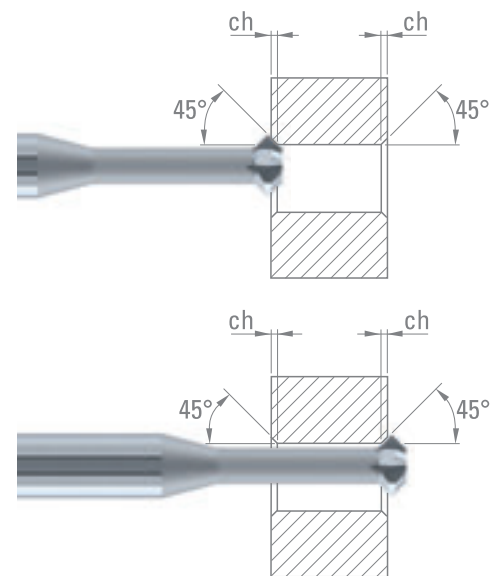

DIXI 7656

FRAISES À RAYONNER

Z = 2



P. 184

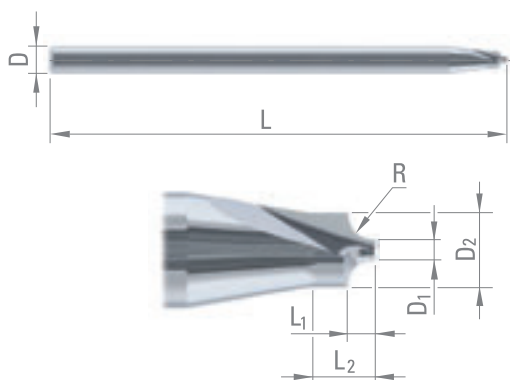

Acier + Pb	Acier faibl. allié	Acier fort. allié	Acier inox aust.	Fontes
Super alliages Ni / Co	Titane, alliage de titane	Alliage Cu Argent Or	Alliage Cu difficile	Alu
Plastique				

D ₁	L ₁	D ₂	L ₂	D _{h5}	L	R _{±0.02}	CARBURE	TiAIN
0.50	0.12	0.74	0.8	3	38	0.10	969577	969578
0.50	0.18	0.86	0.8	3	38	0.15	969586	969597
0.50	0.24	0.98	0.8	3	38	0.20	969587	969598
0.50	0.30	1.10	1.0	3	38	0.25	969588	969599
0.50	0.36	1.22	1.0	3	38	0.30	969589	969600
0.50	0.48	1.46	1.0	3	38	0.40	969590	969601
0.50	0.60	1.70	1.5	3	38	0.50	969591	969602
0.50	0.70	1.90	1.5	3	38	0.60	969592	969603
0.50	0.80	2.10	1.5	3	38	0.70	969593	969604
0.80	0.90	2.60	2.0	3	38	0.80	969594	969605
0.80	1.00	2.80	2.0	3	38	0.90	969595	969606
0.80	1.10	-	-	3	38	1.00	969596	969607

DIXI 7112

FRAISES À CONTOURNER
POUR COMPOSITES / KEVLAR®

Z = 2

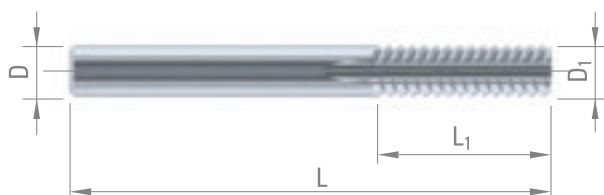

Kevlar®

CONDITIONS DE COUPE:

Contournage Vc = 250 - 500 m/min
Vf = 500 - 2000 mm/min

D ₁	inches	L ₁	D _{h5}	L	CARBURE
5.00		20	5.00	75	26252
6.00		25	6.00	75	26873
6.35	1/4"	25	6.35	75	26264
8.00		25	8.00	75	27851
10.00		25	10.00	75	28072
12.00		25	12.00	75	28073
12.70	1/2"	27	12.70	75	26254





OUTILS SUR DEMANDE

DIXI 7631 SP R L Z =



Quantités

Matière à usiner

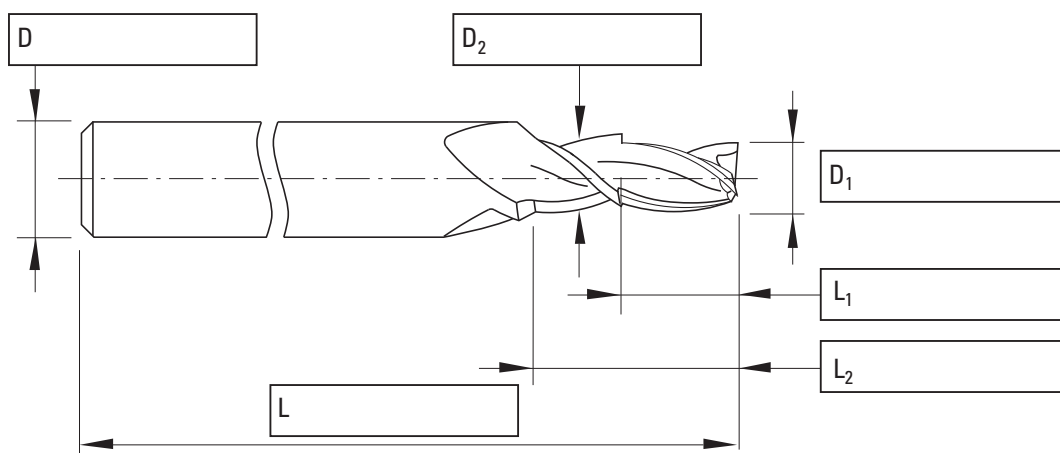

DIXI 7645 SP R L
FRAISES CONIQUES À BOUT PLAT OU HÉMISPHERIQUES

Z =

Quantités

Matière à usiner

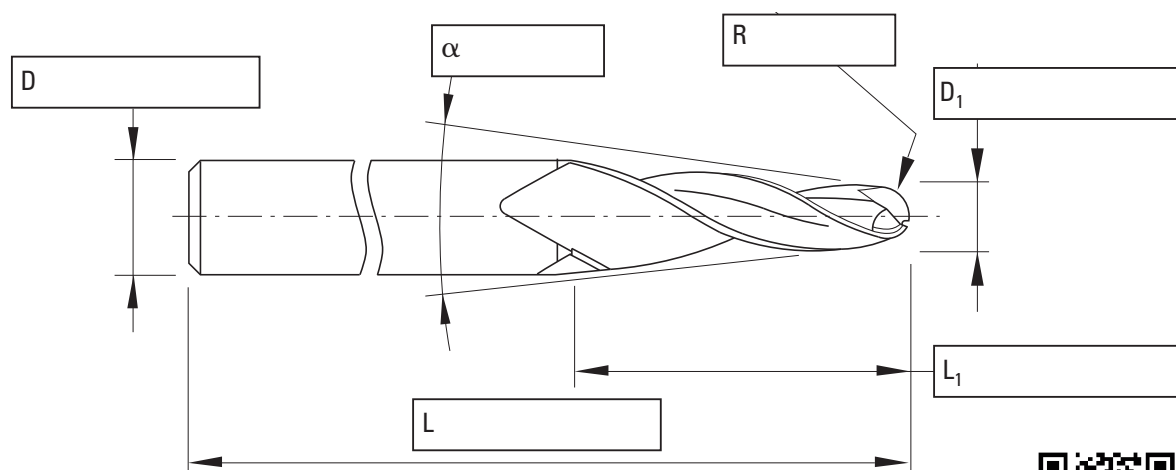
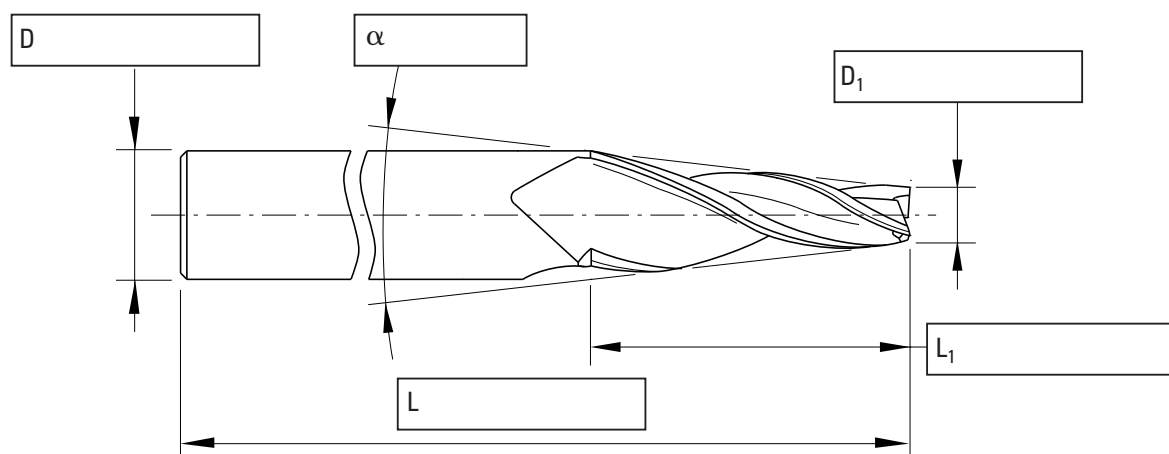

CONSULTEZ NOTRE FORMULAIRE DE DEMANDE D'OFFRES EN LIGNE SUR
WWW.DIXIPOLYTOOL.COM



CHOIX DU NOMBRE DE DENTS



1 Rainurage fermé (poche)

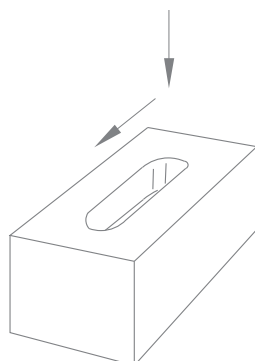

Z 2



2 Rainurage fermé (ramping)

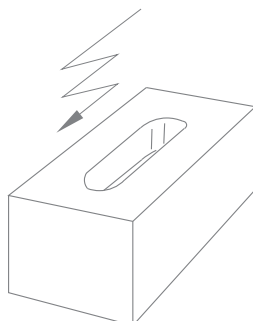

Z 2 - Z 3



3 Rainurage ouvert

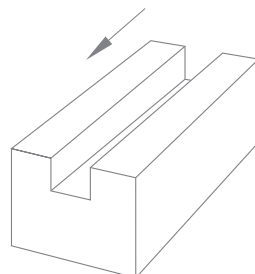

Z 2 - Z 3



Contournage (ébauche)

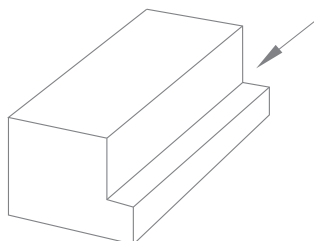

Z 3 - Z 4



Contournage (finition)

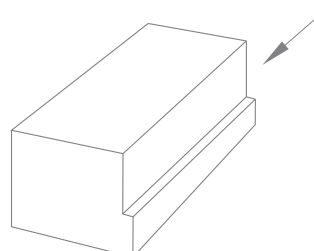

Multident



CONDITIONS DE COUPE

DIXI 7215 Z = 3 Aluminium (Vc 600 - 700 m/min)						
D	Vc [m/min]	n [min -1]	Vf [mm/min]	ap [mm]	ae [mm]	fz [mm]
6	600	31800	6200	9	3.6	0.065
8	600	23'00	6450	12	4.8	0.090
10	600	19100	6300	15	6.0	0.110
12	600	15900	6440	18	7.2	0.135
16	600	11900	6440	24	9.6	0.180

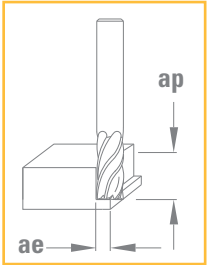

DIXI 7215 Z = 3 Cuivre (Vc 400 - 500 m/min)						
D	Vc [m/min]	n [min -1]	Vf [mm/min]	ap [mm]	ae [mm]	fz [mm]
6	400	21200	4100	9	3.6	0.065
8	400	15900	4300	12	4.8	0.090
10	400	12700	4200	15	6.0	0.110
12	400	10600	4300	18	7.2	0.135
16	400	7900	4250	24	9.6	0.180

DIXI 7215 Z = 3 Aluminium (Vc 500 - 600 m/min)						
D	Vc [m/min]	n [min -1]	Vf [mm/min]	ap [mm]	ae [mm]	fz [mm]
6	500	26500	4780	9	6	0.060
8	500	19900	4780	12	8	0.080
10	500	15900	4780	15	10	0.100
12	500	13250	4780	18	12	0.120
16	500	10000	4780	24	16	0.160

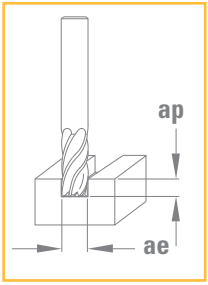

DIXI 7215 Z = 3 Cuivre (Vc 270 - 370 m/min)						
D	Vc [m/min]	n [min -1]	Vf [mm/min]	ap [mm]	ae [mm]	fz [mm]
6	270	14300	2600	9	6	0.060
8	270	10800	2600	12	8	0.080
10	270	8500	2600	15	10	0.100
12	270	7200	2600	18	12	0.120
16	270	5400	2600	24	18	0.160



CONDITIONS DE COUPE

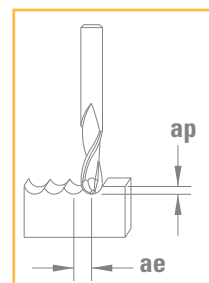

Matières à usiner

			CARBURE	DICUT	TiAIN	DIAMANT	ap [mm]	ae [mm]
			Vc [m/min]	Vc [m/min]	Vc [m/min]	Vc [m/min]		
P	Acier non allié / faiblement allié	< 600 N/mm ²	70 100		90 110		<0.15 x ØD1	<0.5 x ØD1
P	Acier non allié / faiblement allié	600 – 1500 N/mm ²			70 90		<0.15 x ØD1	<0.5 x ØD1
P	Acier de décolletage au plomb		70 100				<0.20 x ØD1	<0.5 x ØD1
P	Acier fortement allié	700 – 1500 N/mm ²			40 70		<0.15 x ØD1	<0.5 x ØD1
M	Acier inoxydable	400 – 700 N/mm ²			70 90		<0.15 x ØD1	<0.5 x ØD1
M	Acier inox. DUPLEX, acier austénitique inox. sans nickel	> 800 N/mm ²			40 70		<0.1 x ØD1	<0.4 x ØD1
K	Fonte grise / Fonte à graphite sphéroïdal perlitique	< 250 HB	70 100		90 110		<0.10 x ØD1	<0.4 x ØD1
K	Fonte alliée / Fonte à graphite sphéroïdal perlitique	> 250 HB	40 70		70 90		<0.15 x ØD1	<0.5 x ØD1
K	Fonte à graphite sphéroïdal ferritique / Fonte malléable		70 100		90 110		<0.10 x ØD1	<0.4 x ØD1
S	Super alliages / Acier inox. réfractaire	Inconel Nimonic Hastelloy			25 35		<0.05 x ØD1	<0.25 x ØD1
S	Titane, alliage de titane		30 45				<0.15 x ØD1	<0.5 x ØD1
N	Alliage de cuivre / bonne usinabilité (laiton – bronze)		140 160				<0.15 x ØD1	<0.5 x ØD1
N	Alliage de cuivre / usinabilité difficile / Bronze à l'aluminium	(CuAlFe) (Ampco)	120 140	170 190	170 190		<0.15 x ØD1	<0.5 x ØD1
N	Alliage d'aluminium	Si < 8%	180 260		230 340		<0.25 x ØD1	<0.5 x ØD1
N	Fonte d'aluminium	Si > 8%	140 160		210 230		<0.25 x ØD1	<0.5 x ØD1
N	Graphite					200 300	<0.30 x ØD1	<0.6 x ØD1
N	Plastique		240 260		300 340		<0.30 x ØD1	<0.6 x ØD1
N	Or, argent		140 160		200 220		<0.15 x ØD1	<0.5 x ØD1

$$n \text{ [tr/min]} = \frac{Vc \text{ [m/min]} \times 1000}{\pi \times D_1 \text{ [mm]}}$$

$$Vf \text{ [mm/min]} = n \text{ [tr/min]} \times fz \text{ [mm]} \times Z$$

Avance par dent **fz [mm]**

$\emptyset D_1$ 0.06 - 0.60	$\emptyset D_1$ 0.60 - 1.00	$\emptyset D_1$ 1.00 - 1.50	$\emptyset D_1$ 1.50 - 3.00	$\emptyset D_1$ 3.00 - 5.00	$\emptyset D_1$ 5.00 - 7.00	$\emptyset D_1$ 7.00 - 10.00	$\emptyset D_1$ 10.00 - 14.00	$\emptyset D_1$ 14.00 - 16.00	$\emptyset D_1$ 16.00 - 20.00
0.0016 - 0.005	0.003 - 0.009	0.005 - 0.01	0.008 - 0.02	0.016 - 0.05	0.026 - 0.06	0.036 - 0.09	0.05 - 0.13	0.07 - 0.15	0.08 - 0.18
0.0012 - 0.004	0.002 - 0.007	0.004 - 0.01	0.006 - 0.02	0.012 - 0.03	0.020 - 0.05	0.027 - 0.07	0.04 - 0.09	0.05 - 0.10	0.06 - 0.13
0.0020 - 0.008	0.004 - 0.013	0.007 - 0.02	0.010 - 0.03	0.020 - 0.07	0.033 - 0.09	0.046 - 0.13	0.07 - 0.18	0.09 - 0.21	0.10 - 0.26
0.0012 - 0.004	0.002 - 0.007	0.004 - 0.01	0.006 - 0.02	0.012 - 0.03	0.020 - 0.05	0.027 - 0.07	0.04 - 0.09	0.05 - 0.10	0.06 - 0.13
0.0012 - 0.004	0.002 - 0.007	0.004 - 0.01	0.006 - 0.02	0.012 - 0.03	0.020 - 0.05	0.027 - 0.07	0.04 - 0.09	0.05 - 0.10	0.06 - 0.13
0.0012 - 0.004	0.002 - 0.007	0.004 - 0.01	0.006 - 0.02	0.012 - 0.03	0.020 - 0.05	0.027 - 0.07	0.04 - 0.09	0.05 - 0.10	0.06 - 0.13
0.0016 - 0.005	0.003 - 0.009	0.005 - 0.01	0.008 - 0.02	0.016 - 0.05	0.026 - 0.06	0.036 - 0.09	0.05 - 0.13	0.07 - 0.15	0.08 - 0.18
0.0012 - 0.004	0.002 - 0.007	0.004 - 0.01	0.006 - 0.02	0.012 - 0.03	0.020 - 0.05	0.027 - 0.07	0.04 - 0.09	0.05 - 0.10	0.06 - 0.13
0.0016 - 0.005	0.003 - 0.009	0.005 - 0.01	0.008 - 0.02	0.016 - 0.05	0.026 - 0.06	0.036 - 0.09	0.05 - 0.13	0.07 - 0.15	0.08 - 0.18
		0.004 - 0.01	0.006 - 0.02	0.012 - 0.03	0.020 - 0.05	0.027 - 0.07	0.04 - 0.09	0.05 - 0.10	0.06 - 0.13
0.0012 - 0.004	0.002 - 0.007	0.004 - 0.01	0.006 - 0.02	0.012 - 0.03	0.020 - 0.05	0.027 - 0.07	0.04 - 0.09	0.05 - 0.10	0.06 - 0.13
0.0020 - 0.008	0.004 - 0.013	0.007 - 0.02	0.010 - 0.03	0.020 - 0.07	0.033 - 0.09	0.046 - 0.13	0.07 - 0.18	0.09 - 0.21	0.10 - 0.26
0.0012 - 0.004	0.002 - 0.007	0.004 - 0.01	0.006 - 0.02	0.012 - 0.03	0.020 - 0.05	0.027 - 0.07	0.04 - 0.09	0.05 - 0.10	0.06 - 0.13
0.0020 - 0.008	0.004 - 0.013	0.007 - 0.02	0.010 - 0.03	0.020 - 0.07	0.033 - 0.09	0.046 - 0.13	0.07 - 0.18	0.09 - 0.21	0.10 - 0.26
0.0020 - 0.008	0.004 - 0.013	0.007 - 0.02	0.010 - 0.03	0.020 - 0.07	0.033 - 0.09	0.046 - 0.13	0.07 - 0.18	0.09 - 0.21	0.10 - 0.26
0.0027 - 0.012	0.005 - 0.020	0.009 - 0.03	0.014 - 0.05	0.027 - 0.10	0.046 - 0.14	0.064 - 0.20	0.09 - 0.27	0.13 - 0.31	0.15 - 0.39
0.0027 - 0.012	0.005 - 0.020	0.009 - 0.03	0.014 - 0.05	0.027 - 0.10	0.046 - 0.14	0.064 - 0.20	0.09 - 0.27	0.13 - 0.31	0.15 - 0.39
0.0020 - 0.008	0.004 - 0.013	0.007 - 0.02	0.010 - 0.03	0.020 - 0.07	0.033 - 0.09	0.046 - 0.13	0.07 - 0.18	0.09 - 0.21	0.10 - 0.26



CONDITIONS DE COUPE

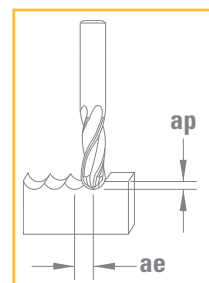

Matières à usiner

			CARBURE		TiAIN		ap [mm]	ae [mm]
			Vc [m/min]	Vc [m/min]	Vc [m/min]	Vc [m/min]		
P	Acier non allié / faiblement allié	< 600 N/mm ²	70	100	90	110	<0.15 x ØD1	<0.3 x ØD1
P	Acier non allié / faiblement allié	600 – 1500 N/mm ²			70	90	<0.15 x ØD1	<0.3 x ØD1
P	Acier de décolletage au plomb		70	100			<0.20 x ØD1	<0.3 x ØD1
P	Acier fortement allié	700 – 1500 N/mm ²			40	70	<0.10 x ØD1	<0.2 x ØD1
M	Acier inoxydable	400 – 700 N/mm ²			70	90	<0.15 x ØD1	<0.3 x ØD1
M	Acier inox. DUPLEX, acier austénitique inox. sans nickel	> 800 N/mm ²			40	70	<0.10 x ØD1	<0.2 x ØD1
K	Fonte grise / Fonte à graphite sphéroïdal perlitique	< 250 HB	70	100	90	110	<0.15 x ØD1	<0.3 x ØD1
K	Fonte allié / Fonte à graphite sphéroïdal perlitique	> 250 HB	40	70	70	90	<0.10 x ØD1	<0.2 x ØD1
K	Fonte à graphite sphéroïdal ferritique / Fonte malléable		70	100	90	110	<0.15 x ØD1	<0.3 x ØD1
S	Super alliages / Acier inox. réfractaire	Inconel Nimonic Hastelloy			25	35	<0.10 x ØD1	<0.2 x ØD1
S	Titane, alliage de titane		30	45			<0.10 x ØD1	<0.2 x ØD1
N	Alliage de cuivre / bonne usinabilité (laiton – bronze)		140	160			<0.15 x ØD1	<0.3 x ØD1
N	Alliage de cuivre / usinabilité difficile / Bronze à l'aluminium (CuAlFe) (Ampco)		120	140	170	190	<0.15 x ØD1	<0.3 x ØD1
N	Alliage d'aluminium	Si < 8%	180	260	230	340	<0.25 x ØD1	<0.3 x ØD1
N	Fonte d'aluminium	Si > 8%	140	160	210	230	<0.25 x ØD1	<0.3 x ØD1
N	Plastique		240	260	300	340	<0.30 x ØD1	<0.4 x ØD1
N	Or, argent		140	160	200	220	<0.15 x ØD1	<0.3 x ØD1

$$n \text{ [tr/min]} = \frac{V_c \text{ [m/min]} \times 1000}{\pi \times D_1 \text{ [mm]}}$$

$$V_f \text{ [mm/min]} = n \text{ [tr/min]} \times f_z \text{ [mm]} \times Z$$

Avance par dent **fz [mm]**

$\emptyset D_1$ 0.20 - 0.60	$\emptyset D_1$ 0.60 - 1.00	$\emptyset D_1$ 1.00 - 1.50	$\emptyset D_1$ 1.50 - 3.00	$\emptyset D_1$ 3.00 - 5.00	$\emptyset D_1$ 5.00 - 7.00	$\emptyset D_1$ 7.00 - 10.00	$\emptyset D_1$ 10.00 - 12.00	$\emptyset D_1$ 12.00 - 20.00	
0.005 - 0.01	0.008 - 0.02	0.016 - 0.05	0.026 - 0.06	0.036 - 0.09	0.05 - 0.13	0.07 - 0.15	0.08 - 0.18	0.11 - 0.22	
0.004 - 0.01	0.006 - 0.02	0.012 - 0.03	0.020 - 0.05	0.027 - 0.07	0.04 - 0.09	0.05 - 0.10	0.06 - 0.13	0.09 - 0.17	
0.007 - 0.02	0.010 - 0.03	0.020 - 0.07	0.033 - 0.09	0.046 - 0.13	0.07 - 0.18	0.09 - 0.21	0.10 - 0.26	0.13 - 0.29	
0.004 - 0.01	0.006 - 0.02	0.012 - 0.03	0.020 - 0.05	0.027 - 0.07	0.04 - 0.09	0.05 - 0.10	0.06 - 0.13	0.09 - 0.17	
0.004 - 0.01	0.006 - 0.02	0.012 - 0.03	0.020 - 0.05	0.027 - 0.07	0.04 - 0.09	0.05 - 0.10	0.06 - 0.13	0.09 - 0.17	
0.004 - 0.01	0.006 - 0.02	0.012 - 0.03	0.020 - 0.05	0.027 - 0.07	0.04 - 0.09	0.05 - 0.10	0.06 - 0.13	0.09 - 0.17	
0.005 - 0.01	0.008 - 0.02	0.016 - 0.05	0.026 - 0.06	0.036 - 0.09	0.05 - 0.13	0.07 - 0.15	0.08 - 0.18	0.11 - 0.21	
0.004 - 0.01	0.006 - 0.02	0.012 - 0.03	0.020 - 0.05	0.027 - 0.07	0.04 - 0.09	0.05 - 0.10	0.06 - 0.13	0.09 - 0.17	
0.005 - 0.01	0.008 - 0.02	0.016 - 0.05	0.026 - 0.06	0.036 - 0.09	0.05 - 0.13	0.07 - 0.15	0.08 - 0.18	0.11 - 0.21	
0.004 - 0.01	0.006 - 0.02	0.012 - 0.03	0.020 - 0.05	0.027 - 0.07	0.04 - 0.09	0.05 - 0.10	0.06 - 0.13	0.09 - 0.17	
0.004 - 0.01	0.006 - 0.02	0.012 - 0.03	0.020 - 0.05	0.027 - 0.07	0.04 - 0.09	0.05 - 0.10	0.06 - 0.13	0.09 - 0.17	
0.007 - 0.02	0.010 - 0.03	0.020 - 0.07	0.033 - 0.09	0.046 - 0.13	0.07 - 0.18	0.09 - 0.21	0.10 - 0.26	0.13 - 0.29	
0.004 - 0.01	0.006 - 0.02	0.012 - 0.03	0.020 - 0.05	0.027 - 0.07	0.04 - 0.09	0.05 - 0.10	0.06 - 0.13	0.09 - 0.17	
0.007 - 0.02	0.010 - 0.03	0.020 - 0.07	0.033 - 0.09	0.046 - 0.13	0.07 - 0.18	0.09 - 0.21	0.10 - 0.26	0.13 - 0.29	
0.007 - 0.02	0.010 - 0.03	0.020 - 0.07	0.033 - 0.09	0.046 - 0.13	0.07 - 0.18	0.09 - 0.21	0.10 - 0.26	0.13 - 0.29	
0.009 - 0.03	0.014 - 0.05	0.027 - 0.10	0.046 - 0.14	0.064 - 0.20	0.09 - 0.27	0.13 - 0.31	0.15 - 0.39	0.18 - 0.42	
0.007 - 0.02	0.010 - 0.03	0.020 - 0.07	0.033 - 0.09	0.046 - 0.13	0.07 - 0.18	0.09 - 0.21	0.10 - 0.26	0.13 - 0.29	



CONDITIONS DE COUPE

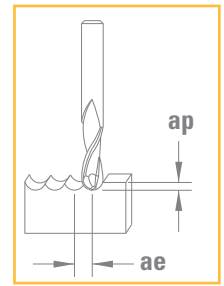

Matières à usiner			CARBURE	DICUT	TiAIN	DIAMANT	ap [mm]	ae [mm]
			Vc [m/min]	Vc [m/min]	Vc [m/min]	Vc [m/min]		
P	Acier non allié / faiblement allié	< 600 N/mm ²	70 100		90 110		<0.15 x ØD1	<0.5 x ØD1
P	Acier non allié / faiblement allié	600 – 1500 N/mm ²			70 90		<0.15 x ØD1	<0.5 x ØD1
P	Acier de décolletage au plomb		70 100				<0.20 x ØD1	<0.5 x ØD1
P	Acier fortement allié	700 – 1500 N/mm ²			40 70		<0.10 x ØD1	<0.4 x ØD1
M	Acier inoxydable	400 – 700 N/mm ²			70 90		<0.15 x ØD1	<0.5 x ØD1
M	Acier inox. DUPLEX, acier austénitique inox. sans nickel	> 800 N/mm ²			40 70		<0.10 x ØD1	<0.4 x ØD1
K	Fonte grise / Fonte à graphite sphéroïdal perlitique	< 250 HB	70 100		90 110		<0.15 x ØD1	<0.5 x ØD1
K	Fonte alliée / Fonte à graphite sphéroïdal perlitique	> 250 HB	40 70		70 90		<0.10 x ØD1	<0.4 x ØD1
K	Fonte à graphite sphéroïdal ferritique / Fonte malléable		70 100		90 110		<0.15 x ØD1	<0.5 x ØD1
S	Super alliages / Acier inox. réfractaire	Inconel Nimonic Hastelloy			25 35		< 0.10 x ØD1	<.0.10 x ØD1
S	Titane, alliage de titane		30 45				<0.10 x ØD1	<0.4 x ØD1
N	Alliage de cuivre / bonne usinabilité (laiton – bronze)		140 160				<0.15 x ØD1	<0.5 x ØD1
N	Alliage de cuivre / usinabilité difficile / Bronze à l'aluminium (CuAlFe) (Ampco)		120 140	170 190	170 190		<0.15 x ØD1	<0.5 x ØD1
N	Alliage d'aluminium	Si < 8%	180 240		230 340		<0.25 x ØD1	<0.5 x ØD1
N	Fonte d'aluminium	Si > 8%	140 160			200 300	<0.25 x ØD1	<0.5 x ØD1
N	Graphite					200 300	<0.30 x ØD1	<0.6 x ØD1
N	Plastique		240 260		300 340		<0.30 x ØD1	<0.6 x ØD1
N	Or, argent		140 160		200 220		<0.15 x ØD1	<0.5 x ØD1

n et Vf sont indicatifs et devront être ajustées en fonction de la longueur L₂ de l'outil

$$n \text{ [tr/min]} = \frac{V_c \text{ [m/min]} \times 1000}{\pi \times D_1 \text{ [mm]}}$$

$$V_f \text{ [mm/min]} = n \text{ [tr/min]} \times f_z \text{ [mm]} \times Z$$

Avance par dent **fz [mm]**

$\emptyset D_1$ 0.20 - 0.60	$\emptyset D_1$ 0.60 - 1.00	$\emptyset D_1$ 1.00 - 1.50	$\emptyset D_1$ 1.50 - 3.00	$\emptyset D_1$ 3.00 - 5.00	$\emptyset D_1$ 5.00 - 7.00	$\emptyset D_1$ 7.00 - 10.00	$\emptyset D_1$ 10.00 - 12.00
0.0014 - 0.005	0.003 - 0.008	0.005 - 0.01	0.007 - 0.02	0.014 - 0.04	0.023 - 0.06	0.032 - 0.08	0.05 - 0.11
0.0010 - 0.003	0.002 - 0.006	0.003 - 0.01	0.005 - 0.015	0.010 - 0.03	0.017 - 0.04	0.024 - 0.06	0.03 - 0.08
0.0017 - 0.007	0.003 - 0.012	0.006 - 0.02	0.009 - 0.03	0.017 - 0.06	0.029 - 0.08	0.040 - 0.12	0.06 - 0.16
0.0010 - 0.003	0.002 - 0.006	0.003 - 0.01	0.005 - 0.015	0.010 - 0.03	0.017 - 0.04	0.024 - 0.06	0.03 - 0.08
0.0010 - 0.003	0.002 - 0.006	0.003 - 0.01	0.005 - 0.015	0.010 - 0.03	0.017 - 0.04	0.024 - 0.06	0.03 - 0.08
0.0010 - 0.003	0.002 - 0.006	0.003 - 0.01	0.005 - 0.015	0.010 - 0.03	0.017 - 0.04	0.024 - 0.06	0.03 - 0.08
0.0014 - 0.005	0.003 - 0.008	0.005 - 0.01	0.007 - 0.02	0.014 - 0.04	0.023 - 0.06	0.032 - 0.08	0.05 - 0.11
0.0010 - 0.003	0.002 - 0.006	0.003 - 0.01	0.005 - 0.015	0.010 - 0.03	0.017 - 0.04	0.024 - 0.06	0.03 - 0.08
0.0014 - 0.005	0.003 - 0.008	0.005 - 0.01	0.007 - 0.02	0.014 - 0.04	0.023 - 0.06	0.032 - 0.08	0.05 - 0.11
		0.003 - 0.01	0.005 - 0.015	0.010 - 0.03	0.017 - 0.04	0.024 - 0.06	0.03 - 0.08
0.0010 - 0.003	0.002 - 0.006	0.003 - 0.01	0.005 - 0.015	0.010 - 0.03	0.017 - 0.04	0.024 - 0.06	0.03 - 0.08
0.0017 - 0.007	0.003 - 0.012	0.006 - 0.02	0.009 - 0.03	0.017 - 0.06	0.029 - 0.08	0.040 - 0.12	0.06 - 0.16
0.0010 - 0.003	0.002 - 0.006	0.003 - 0.01	0.005 - 0.015	0.010 - 0.03	0.017 - 0.04	0.024 - 0.06	0.03 - 0.08
0.0017 - 0.007	0.003 - 0.012	0.006 - 0.02	0.009 - 0.03	0.017 - 0.06	0.029 - 0.08	0.040 - 0.12	0.06 - 0.16
0.0017 - 0.007	0.003 - 0.012	0.006 - 0.02	0.009 - 0.03	0.017 - 0.06	0.029 - 0.08	0.040 - 0.12	0.06 - 0.16
0.0024 - 0.010	0.005 - 0.017	0.008 - 0.03	0.012 - 0.04	0.024 - 0.09	0.040 - 0.12	0.056 - 0.17	0.08 - 0.24
0.0024 - 0.010	0.005 - 0.017	0.008 - 0.03	0.012 - 0.04	0.024 - 0.09	0.040 - 0.12	0.056 - 0.17	0.08 - 0.24
0.0017 - 0.007	0.003 - 0.012	0.006 - 0.02	0.009 - 0.03	0.017 - 0.06	0.029 - 0.08	0.040 - 0.12	0.06 - 0.16



CONDITIONS DE COUPE

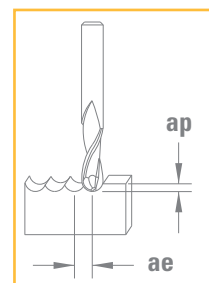

Matières à usiner

			CARBURE	TiAIN	DIAMANT	ap [mm]	ae [mm]
			Vc [m/min]	Vc [m/min]	Vc [m/min]		
P	Acier non allié / faiblement allié	< 600 N/mm ²	60 90	80 100		<0.10 x ØD1	<0.3 x ØD1
P	Acier non allié / faiblement allié	600 – 1500 N/mm ²		60 80		<0.10 x ØD1	<0.3 x ØD1
P	Acier de décolletage au plomb		60 90	80 100		<0.15 x ØD1	<0.3 x ØD1
P	Acier fortement allié	700 – 1500 N/mm ²		30 60		<0.05 x ØD1	<0.2 x ØD1
M	Acier inoxydable	400 – 700 N/mm ²		60 80		<0.10 x ØD1	<0.3 x ØD1
M	Acier inox. DUPLEX, acier austénitique inox. sans nickel	> 800 N/mm ²		30 60		<0.05 x ØD1	<0.2 x ØD1
K	Fonte grise / Fonte à graphite sphéroïdal perlitique	< 250 HB	60 90	80 100		<0.10 x ØD1	<0.3 x ØD1
K	Fonte alliée / Fonte à graphite sphéroïdal perlitique	> 250 HB	30 50	60 80		<0.05 x ØD1	<0.2 x ØD1
K	Fonte à graphite sphéroïdal ferritique / Fonte malléable		60 90	80 100		<0.10 x ØD1	<0.3 x ØD1
S	Super alliages / Acier inox. réfractaire	Inconel Nimonic Hastelloy		20 30		<0.05 x ØD1	<0.2 x ØD1
S	Titane, alliage de titane		25 35	30 50		<0.05 x ØD1	<0.2 x ØD1
N	Alliage de cuivre / bonne usinabilité (laiton – bronze)		100 130	140 180		<0.10 x ØD1	<0.3 x ØD1
N	Alliage de cuivre / usinabilité difficile / Bronze à l'aluminium	(CuAlFe) (Ampco)	90 110	130 160		<0.10 x ØD1	<0.3 x ØD1
N	Alliage d'aluminium	Si < 8%	130 180	150 250		<0.20 x ØD1	<0.3 x ØD1
N	Fonte d'aluminium	Si > 8%	100 130		200 300	<0.20 x ØD1	<0.3 x ØD1
N	Graphite				200 300	<0.25 x ØD1	<0.4 x ØD1
N	Plastique		180 220	200 250		<0.25 x ØD1	<0.4 x ØD1
N	Or, argent		100 130	140 180		<0.10 x ØD1	<0.3 x ØD1

$$n \text{ [tr/min]} = \frac{Vc \text{ [m/min]} \times 1000}{\pi \times D_1 \text{ [mm]}}$$

$$Vf \text{ [mm/min]} = n \text{ [tr/min]} \times fz \text{ [mm]} \times Z$$

Avance par dent **fz [mm]**

Ø D ₁ 2.00 - 2.50	Ø D ₁ 2.50 - 3.00	Ø D ₁ 3.00 - 4.00	Ø D ₁ 4.00 - 5.00	Ø D ₁ 5.00 - 6.00	Ø D ₁ 6.00 - 8.00	Ø D ₁ 8.00 - 10.00	Ø D ₁ 10.00 - 14.00	Ø D ₁ 14.00 - 16.00	Ø D ₁ 16.00 - 20.00
0.010 - 0.021	0.012 - 0.03	0.014 - 0.03	0.019 - 0.04	0.024 - 0.05	0.029 - 0.07	0.038 - 0.08	0.05 - 0.12	0.07 - 0.13	0.08 - 0.17
0.007 - 0.015	0.009 - 0.02	0.011 - 0.02	0.014 - 0.03	0.018 - 0.04	0.022 - 0.05	0.029 - 0.06	0.04 - 0.08	0.05 - 0.10	0.06 - 0.12
0.012 - 0.030	0.015 - 0.04	0.018 - 0.05	0.024 - 0.06	0.030 - 0.07	0.036 - 0.10	0.048 - 0.12	0.06 - 0.17	0.08 - 0.19	0.10 - 0.24
0.007 - 0.015	0.009 - 0.02	0.011 - 0.02	0.014 - 0.03	0.018 - 0.04	0.022 - 0.05	0.029 - 0.06	0.04 - 0.08	0.05 - 0.10	0.06 - 0.12
0.007 - 0.015	0.009 - 0.02	0.011 - 0.02	0.014 - 0.03	0.018 - 0.04	0.022 - 0.05	0.029 - 0.06	0.04 - 0.08	0.05 - 0.10	0.06 - 0.12
0.007 - 0.015	0.009 - 0.02	0.011 - 0.02	0.014 - 0.03	0.018 - 0.04	0.022 - 0.05	0.029 - 0.06	0.04 - 0.08	0.05 - 0.10	0.06 - 0.12
0.010 - 0.021	0.012 - 0.03	0.014 - 0.03	0.019 - 0.04	0.024 - 0.05	0.029 - 0.07	0.038 - 0.08	0.05 - 0.12	0.07 - 0.13	0.08 - 0.17
0.007 - 0.015	0.009 - 0.02	0.011 - 0.02	0.014 - 0.03	0.018 - 0.04	0.022 - 0.05	0.029 - 0.06	0.04 - 0.08	0.05 - 0.10	0.06 - 0.12
0.010 - 0.021	0.012 - 0.03	0.014 - 0.03	0.019 - 0.04	0.024 - 0.05	0.029 - 0.07	0.038 - 0.08	0.05 - 0.12	0.07 - 0.13	0.08 - 0.17
0.007 - 0.015	0.009 - 0.02	0.011 - 0.02	0.014 - 0.03	0.018 - 0.04	0.022 - 0.05	0.029 - 0.06	0.04 - 0.08	0.05 - 0.10	0.06 - 0.12
0.007 - 0.015	0.009 - 0.02	0.011 - 0.02	0.014 - 0.03	0.018 - 0.04	0.022 - 0.05	0.029 - 0.06	0.04 - 0.08	0.05 - 0.10	0.06 - 0.12
0.012 - 0.030	0.015 - 0.04	0.018 - 0.05	0.024 - 0.06	0.030 - 0.07	0.036 - 0.10	0.048 - 0.12	0.06 - 0.17	0.08 - 0.19	0.10 - 0.24
0.007 - 0.015	0.009 - 0.02	0.011 - 0.02	0.014 - 0.03	0.018 - 0.04	0.022 - 0.05	0.029 - 0.06	0.04 - 0.08	0.05 - 0.10	0.06 - 0.12
0.012 - 0.030	0.015 - 0.04	0.018 - 0.05	0.024 - 0.06	0.030 - 0.07	0.036 - 0.10	0.048 - 0.12	0.06 - 0.17	0.08 - 0.19	0.10 - 0.24
0.012 - 0.030	0.015 - 0.04	0.018 - 0.05	0.024 - 0.06	0.030 - 0.07	0.036 - 0.10	0.048 - 0.12	0.06 - 0.17	0.08 - 0.19	0.10 - 0.24
0.017 - 0.045	0.021 - 0.05	0.025 - 0.07	0.034 - 0.09	0.042 - 0.11	0.050 - 0.14	0.067 - 0.18	0.08 - 0.25	0.12 - 0.29	0.13 - 0.36
0.017 - 0.045	0.021 - 0.05	0.025 - 0.07	0.034 - 0.09	0.042 - 0.11	0.050 - 0.14	0.067 - 0.18	0.08 - 0.25	0.12 - 0.29	0.13 - 0.36
0.012 - 0.030	0.015 - 0.04	0.018 - 0.05	0.024 - 0.06	0.030 - 0.07	0.036 - 0.10	0.048 - 0.12	0.06 - 0.17	0.08 - 0.19	0.10 - 0.24



CONDITIONS DE COUPE

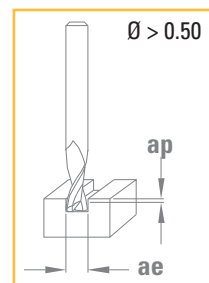
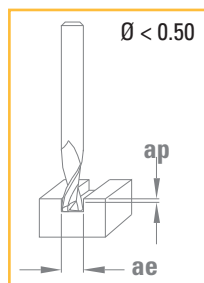

Matières à usiner

			CARBURE		TiAlN		ap [mm]	ae [mm]	ap [mm]	ae [mm]
			Vc [m/min]	Vc [m/min]	Vc [m/min]	Vc [m/min]				
P	Acier non allié / faiblement allié	< 600 N/mm ²	70	100	90	110	< 0.5 x ØD1	1 x ØD1	< 1 x ØD1	1 x ØD1
P	Acier non allié / faiblement allié	600 – 1500 N/mm ²			70	90	< 0.3 x ØD1	1 x ØD1	< 0.6 x ØD1	1 x ØD1
P	Acier de décolletage au plomb		70	100			< 0.5 x ØD1	1 x ØD1	< 1 x ØD1	1 x ØD1
P	Acier fortement allié	700 – 1500 N/mm ²			40	70	< 0.2 x ØD1	1 x ØD1	< 0.5 x ØD1	1 x ØD1
M	Acier inoxydable	400 – 700 N/mm ²			70	90	< 0.5 x ØD1	1 x ØD1	< 0.8 x ØD1	1 x ØD1
M	Acier inox. DUPLEX, acier austénitique inox. sans nickel	> 800 N/mm ²			40	70	< 0.5 x ØD1	1 x ØD1	< 0.8 x ØD1	1 x ØD1
K	Fonte grise / Fonte à graphite sphéroïdal perlitique	< 250 HB	70	100	90	110	< 0.5 x ØD1	1 x ØD1	< 1 x ØD1	1 x ØD1
K	Fonte alliée / Fonte à graphite sphéroïdal perlitique	> 250 HB	40	70	70	90	< 0.3 x ØD1	1 x ØD1	< 0.6 x ØD1	1 x ØD1
K	Fonte à graphite sphéroïdal ferritique / Fonte malléable		70	100	90	110	< 0.3 x ØD1	1 x ØD1	< 0.6 x ØD1	1 x ØD1
S	Super alliages / Acier inox. réfractaire	Inconel Nimonic Hastelloy			25	35			< 0.4 x ØD1	1 x ØD1
N	Titane, alliage de titane		30	45			< 0.3 x ØD1	1 x ØD1	< 0.5 x ØD1	1 x ØD1
N	Alliage de cuivre / bonne usinabilité (laiton – bronze)		140	160			< 0.5 x ØD1	1 x ØD1	< 1 x ØD1	1 x ØD1
N	Alliage de cuivre / usinabilité difficile / Bronze à l'aluminium (Ampco)	(CuAlFe)	120	140	170	190	< 0.3 x ØD1	1 x ØD1	< 0.7 x ØD1	1 x ØD1
N	Alliage d'aluminium	Si < 8%	180	260	230	340	< 0.6 x ØD1	1 x ØD1	< 1.2 x ØD1	1 x ØD1
N	Fonte d'aluminium	Si > 8%	140	160	210	230	< 0.4 x ØD1	1 x ØD1	< 0.9 x ØD1	1 x ØD1
N	Plastique		240	260	300	340	< 0.6 x ØD1	1 x ØD1	< 1.2 x ØD1	1 x ØD1
N	Or, argent		140	160	200	220	< 0.6 x ØD1	1 x ØD1	< 0.9 x ØD1	1 x ØD1

DIXI 7202 DIAMANT

CONDITIONS DE COUPE

Matières à usiner

		DIAMANT		ap [mm]	ae [mm]
		Vc [m/min]	Vc [m/min]		
N	Graphite	200	300	< 1 x ØD1	< 1 x ØD1



$$n \text{ [tr/min]} = \frac{Vc \text{ [m/min]} \times 1000}{\pi \times D_1 \text{ [mm]}}$$

$$Vf \text{ [mm/min]} = n \text{ [tr/min]} \times fz \text{ [mm]} \times Z$$

Avance par dent **fz [mm]**

Ø D ₁ 0.04 - 0.50	Ø D ₁ 0.50 - 1.00	Ø D ₁ 1.00 - 1.50	Ø D ₁ 1.50 - 3.00	Ø D ₁ 3.00 - 5.00	Ø D ₁ 5.00 - 7.00	Ø D ₁ 7.00 - 10.00	Ø D ₁ 10.00 - 13.00	Ø D ₁ 13.00 - 16.00	Ø D ₁ 16.00 - 20.00
0.003 - 0.01	0.006 - 0.015	0.012 - 0.020	0.016 - 0.04	0.02 - 0.06	0.03 - 0.09	0.04 - 0.11	0.05 - 0.12	0.06 - 0.13	0.07 - 0.14
0.003 - 0.01	0.006 - 0.015	0.012 - 0.020	0.016 - 0.04	0.02 - 0.06	0.03 - 0.09	0.04 - 0.11	0.05 - 0.12	0.06 - 0.13	0.07 - 0.14
0.003 - 0.01	0.006 - 0.015	0.012 - 0.020	0.016 - 0.04	0.02 - 0.06	0.03 - 0.09	0.04 - 0.11	0.05 - 0.14	0.07 - 0.16	0.08 - 0.20
0.002 - 0.01	0.006 - 0.015	0.012 - 0.020	0.016 - 0.04	0.02 - 0.06	0.03 - 0.09	0.04 - 0.11	0.05 - 0.12	0.06 - 0.13	0.07 - 0.14
0.002 - 0.01	0.006 - 0.015	0.012 - 0.020	0.016 - 0.04	0.02 - 0.06	0.03 - 0.09	0.04 - 0.11	0.05 - 0.12	0.06 - 0.13	0.07 - 0.14
0.002 - 0.01	0.006 - 0.015	0.012 - 0.020	0.016 - 0.04	0.02 - 0.06	0.03 - 0.09	0.04 - 0.11	0.05 - 0.12	0.06 - 0.13	0.07 - 0.14
0.003 - 0.01	0.006 - 0.015	0.012 - 0.020	0.016 - 0.04	0.02 - 0.06	0.03 - 0.09	0.04 - 0.11	0.05 - 0.12	0.06 - 0.13	0.07 - 0.14
0.003 - 0.01	0.006 - 0.015	0.012 - 0.020	0.016 - 0.04	0.02 - 0.06	0.03 - 0.09	0.04 - 0.11	0.05 - 0.12	0.06 - 0.13	0.07 - 0.14
0.003 - 0.01	0.006 - 0.015	0.012 - 0.020	0.016 - 0.04	0.02 - 0.06	0.03 - 0.09	0.04 - 0.11	0.05 - 0.12	0.06 - 0.13	0.07 - 0.14
0.002 - 0.01	0.006 - 0.015	0.012 - 0.020	0.016 - 0.04	0.02 - 0.06	0.03 - 0.09	0.04 - 0.11	0.05 - 0.12	0.06 - 0.13	0.07 - 0.14
0.003 - 0.01	0.006 - 0.015	0.012 - 0.020	0.016 - 0.04	0.02 - 0.06	0.03 - 0.09	0.04 - 0.11	0.05 - 0.14	0.07 - 0.16	0.08 - 0.20
0.003 - 0.01	0.006 - 0.015	0.012 - 0.020	0.016 - 0.04	0.02 - 0.06	0.03 - 0.09	0.04 - 0.11	0.05 - 0.12	0.06 - 0.13	0.07 - 0.14
0.003 - 0.01	0.006 - 0.015	0.012 - 0.020	0.016 - 0.04	0.02 - 0.06	0.03 - 0.09	0.04 - 0.11	0.05 - 0.14	0.07 - 0.16	0.08 - 0.20
0.003 - 0.01	0.006 - 0.015	0.012 - 0.020	0.016 - 0.04	0.02 - 0.06	0.03 - 0.09	0.04 - 0.11	0.05 - 0.14	0.07 - 0.16	0.08 - 0.20
0.003 - 0.01	0.006 - 0.015	0.012 - 0.020	0.016 - 0.04	0.02 - 0.06	0.03 - 0.09	0.04 - 0.11	0.05 - 0.21	0.10 - 0.24	0.11 - 0.30
0.003 - 0.01	0.006 - 0.015	0.012 - 0.020	0.016 - 0.04	0.02 - 0.06	0.03 - 0.09	0.04 - 0.11	0.06 - 0.14	0.07 - 0.16	0.08 - 0.20

L'avance en plongée (V_{fp}) d'une fraise Z = 2 (perçage) doit être réduite de 40 à 80 % en fonction de la matière à usiner.

Avance par dent

Ø D ₁ 0.04 - 0.50	Ø D ₁ 0.50 - 1.00	Ø D ₁ 1.00 - 1.50	Ø D ₁ 1.50 - 3.00	Ø D ₁ 3.00 - 5.00	Ø D ₁ 5.00 - 7.00	Ø D ₁ 7.00 - 10.00	Ø D ₁ 10.00 - 13.00	Ø D ₁ 13.00 - 16.00	Ø D ₁ 16.00 - 20.00
0.003 - 0.01	0.006 - 0.015	0.012 - 0.020	0.016 - 0.04	0.02 - 0.06	0.03 - 0.09	0.04 - 0.11	0.05 - 0.14	0.07 - 0.16	0.08 - 0.20



CONDITIONS DE COUPE

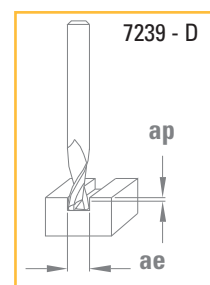
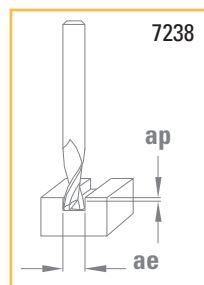

Matières à usiner

			CARBURE		TiAlN		ap [mm]	ae [mm]	ap [mm]	ae [mm]
			Vc [m/min]	Vc [m/min]	Vc [m/min]	Vc [m/min]				
P	Acier non allié / faiblement allié	< 600 N/mm ²	70	100	90	110	< 0.10 x ØD1	1 x ØD1	< 0.04 x ØD1	1 x ØD1
P	Acier non allié / faiblement allié	600 – 1500 N/mm ²			70	90	< 0.10 x ØD1	1 x ØD1	< 0.04 x ØD1	1 x ØD1
P	Acier de décolletage au plomb		70	100			< 0.12x ØD1	1 x ØD1	< 0.06 x ØD1	1 x ØD1
P	Acier fortement allié	700 – 1500 N/mm ²			40	70	< 0.10 x ØD1	1 x ØD1	< 0.04 x ØD1	1 x ØD1
M	Acier inoxydable	400 – 700 N/mm ²			70	90	< 0.10x ØD1	1 x ØD1	< 0.04 x ØD1	1 x ØD1
M	Acier inox. DUPLEX, acier austénitique inox. sans nickel	> 800 N/mm ²			40	70	< 0.10 x ØD1	1 x ØD1	< 0.04 x ØD1	1 x ØD1
K	Fonte grise / Fonte à graphite sphéroïdal perlitique	< 250 HB	70	100	90	110	< 0.10 x ØD1	1 x ØD1	< 0.04 x ØD1	1 x ØD1
K	Fonte alliée / Fonte à graphite sphéroïdal perlitique	> 250 HB	40	70	70	90	< 0.10 x ØD1	1 x ØD1	< 0.04 x ØD1	1 x ØD1
K	Fonte à graphite sphéroïdal ferritique / Fonte malléable		70	100	90	110	< 0.10 x ØD1	1 x ØD1	< 0.04 x ØD1	1 x ØD1
S	Super alliages / Acier inox. réfractaire	Inconel Nimonic Hastelloy			25	35	< 0.10 x ØD1	1 x ØD1	< 0.04 x ØD1	1 x ØD1
S	Titane, alliage de titane		30	45			< 0.10 x ØD1	1 x ØD1	< 0.04 x ØD1	1 x ØD1
N	Alliage de cuivre / bonne usinabilité (laiton – bronze)		140	160			< 0.12 x ØD1	1 x ØD1	< 0.06 x ØD1	1 x ØD1
N	Alliage de cuivre / usinabilité difficile / Bronze à l'aluminium	(CuAlFe) (Ampco)	120	140	170	190	< 0.10 x ØD1	1 x ØD1	< 0.04 x ØD1	1 x ØD1
N	Alliage d'aluminium	Si < 8%	180	260	230	340	< 0.12 x ØD1	1 x ØD1	< 0.06 x ØD1	1 x ØD1
N	Fonte d'aluminium	Si > 8%	140	160	210	230	< 0.12 x ØD1	1 x ØD1	< 0.06 x ØD1	1 x ØD1
N	Plastique		240	260	300	340	< 0.15 x ØD1	1 x ØD1	< 0.10 x ØD1	1 x ØD1
N	Or, argent		140	160	200	220	< 0.12 x ØD1	1 x ØD1	< 0.06 x ØD1	1 x ØD1

n et Vf sont indicatifs et devront être ajustées en fonction de la longueur L₂ de l'outil.

L'avance en plongée (Vfp) d'une fraise Z = 2 (perçage) doit être réduite de 40 à 80 % en fonction de la matière à usiner.



$$n \text{ [tr/min]} = \frac{V_c \text{ [m/min]} \times 1000}{\pi \times D_1 \text{ [mm]}}$$

$$V_f \text{ [mm/min]} = n \text{ [tr/min]} \times f_z \text{ [mm]} \times Z$$

Avance par dent **fz [mm]**

$\emptyset D_1$ 0.15 - 0.30	$\emptyset D_1$ 0.30 - 0.40	$\emptyset D_1$ 0.40 - 0.60	$\emptyset D_1$ 0.60 - 0.90	$\emptyset D_1$ 0.90 - 1.20	$\emptyset D_1$ 1.20 - 1.50	$\emptyset D_1$ 1.50 - 1.80	$\emptyset D_1$ 1.80 - 2.10	$\emptyset D_1$ 2.10 - 2.50	$\emptyset D_1$ 2.50 - 3.00
0.002 - 0.003	0.002 - 0.004	0.003 - 0.01	0.008 - 0.012	0.010 - 0.015	0.012 - 0.016	0.013 - 0.02	0.015 - 0.022	0.02 - 0.025	0.022 - 0.04
0.002 - 0.003	0.002 - 0.004	0.003 - 0.01	0.008 - 0.012	0.010 - 0.015	0.012 - 0.016	0.013 - 0.02	0.015 - 0.022	0.02 - 0.025	0.022 - 0.04
0.002 - 0.003	0.002 - 0.004	0.003 - 0.01	0.008 - 0.012	0.010 - 0.015	0.012 - 0.016	0.013 - 0.02	0.015 - 0.022	0.02 - 0.025	0.022 - 0.04
0.0003 - 0.001	0.002 - 0.003	0.002 - 0.004	0.003 - 0.01	0.008 - 0.012	0.010 - 0.015	0.012 - 0.016	0.013 - 0.02	0.015 - 0.022	0.02 - 0.025
0.002 - 0.003	0.002 - 0.004	0.003 - 0.01	0.008 - 0.012	0.010 - 0.015	0.012 - 0.016	0.013 - 0.02	0.015 - 0.022	0.02 - 0.025	0.022 - 0.04
0.0003 - 0.001	0.002 - 0.003	0.002 - 0.004	0.003 - 0.01	0.008 - 0.012	0.010 - 0.015	0.012 - 0.016	0.013 - 0.02	0.015 - 0.022	0.02 - 0.025
0.002 - 0.003	0.002 - 0.004	0.003 - 0.01	0.008 - 0.012	0.010 - 0.015	0.012 - 0.016	0.013 - 0.02	0.015 - 0.022	0.02 - 0.025	0.022 - 0.04
0.002 - 0.003	0.002 - 0.004	0.003 - 0.01	0.008 - 0.012	0.010 - 0.015	0.012 - 0.016	0.013 - 0.02	0.015 - 0.022	0.02 - 0.025	0.022 - 0.04
		0.003 - 0.01	0.008 - 0.012	0.010 - 0.015	0.012 - 0.016	0.013 - 0.02	0.015 - 0.022	0.02 - 0.025	0.022 - 0.04
0.002 - 0.003	0.002 - 0.004	0.003 - 0.01	0.008 - 0.012	0.010 - 0.015	0.012 - 0.016	0.013 - 0.02	0.015 - 0.022	0.02 - 0.025	0.022 - 0.04
0.002 - 0.003	0.002 - 0.004	0.003 - 0.01	0.008 - 0.012	0.010 - 0.015	0.012 - 0.016	0.013 - 0.02	0.015 - 0.022	0.02 - 0.025	0.022 - 0.04
0.002 - 0.003	0.002 - 0.004	0.003 - 0.01	0.008 - 0.012	0.010 - 0.015	0.012 - 0.016	0.013 - 0.02	0.015 - 0.022	0.02 - 0.025	0.022 - 0.04
0.002 - 0.003	0.002 - 0.004	0.003 - 0.01	0.008 - 0.012	0.010 - 0.015	0.012 - 0.016	0.013 - 0.02	0.015 - 0.022	0.02 - 0.025	0.022 - 0.04
0.002 - 0.003	0.002 - 0.004	0.003 - 0.01	0.008 - 0.012	0.010 - 0.015	0.012 - 0.016	0.013 - 0.02	0.015 - 0.022	0.02 - 0.025	0.022 - 0.04
0.002 - 0.003	0.002 - 0.004	0.003 - 0.01	0.008 - 0.012	0.010 - 0.015	0.012 - 0.016	0.013 - 0.02	0.015 - 0.022	0.02 - 0.025	0.022 - 0.04
0.002 - 0.003	0.002 - 0.004	0.003 - 0.01	0.008 - 0.012	0.010 - 0.015	0.012 - 0.016	0.013 - 0.02	0.015 - 0.022	0.02 - 0.025	0.022 - 0.04
0.002 - 0.003	0.002 - 0.004	0.003 - 0.01	0.008 - 0.012	0.010 - 0.015	0.012 - 0.016	0.013 - 0.02	0.015 - 0.022	0.02 - 0.025	0.022 - 0.04
0.002 - 0.003	0.002 - 0.004	0.003 - 0.01	0.008 - 0.012	0.010 - 0.015	0.012 - 0.016	0.013 - 0.02	0.015 - 0.022	0.02 - 0.025	0.022 - 0.04
0.002 - 0.003	0.002 - 0.004	0.003 - 0.01	0.008 - 0.012	0.010 - 0.015	0.012 - 0.016	0.013 - 0.02	0.015 - 0.022	0.02 - 0.025	0.022 - 0.04



CONDITIONS DE COUPE

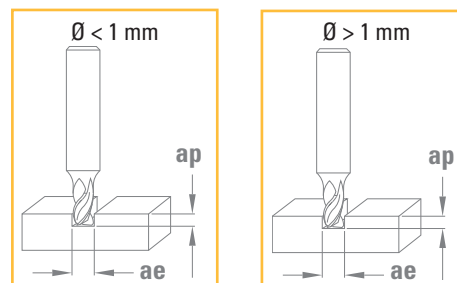

Matières à usiner

			CARBURE		TiAlN		$\varnothing < 1 \text{ mm}$		$\varnothing > 1 \text{ mm}$	
			Vc [m/min]	Vc [m/min]	Vc [m/min]	Vc [m/min]	ap [mm]	ae [mm]	ap [mm]	ae [mm]
P	Acier non allié / faiblement allié	< 600 N/mm ²	70	100	90	110	< 0.5 x ØD1	1 x ØD1	< 1.0 x ØD1	1 x ØD1
P	Acier non allié / faiblement allié	600 – 1500 N/mm ²	50	80	70	90	< 0.3 x ØD1	1 x ØD1	< 0.6 x ØD1	1 x ØD1
P	Acier de décolletage au plomb		70	100			< 0.5 x ØD1	1 x ØD1	< 1 x ØD1	1 x ØD1
P	Acier fortement allié	700 – 1500 N/mm ²			40	70	< 0.2 x ØD1	1 x ØD1	< 0.5 x ØD1	1 x ØD1
M	Acier inoxydable	400 – 700 N/mm ²	40	60	70	90	< 0.5 x ØD1	1 x ØD1	< 0.8 x ØD1	1 x ØD1
M	Acier inox. DUPLEX, acier austénitique inox. sans nickel	> 800 N/mm ²			40	70	< 0.2 x ØD1	1 x ØD1	< 0.5 x ØD1	1 x ØD1
K	Fonte grise / Fonte à graphite sphéroïdal perlitique	< 250 HB	70	100	90	110	< 0.5 x ØD1	1 x ØD1	< 1 x ØD1	1 x ØD1
K	Fonte alliée / Fonte à graphite sphéroïdal perlitique	> 250 HB	40	70	70	90	< 0.3 x ØD1	1 x ØD1	< 0.6 x ØD1	1 x ØD1
K	Fonte à graphite sphéroïdal ferritique / Fonte malléable		70	100	90	110	< 0.3 x ØD1	1 x ØD1	< 0.6 x ØD1	1 x ØD1
S	Super alliages / Acier inox. réfractaire	Inconel Nimonic Hastelloy			25	35			< 0.4 x ØD1	1 x ØD1
S	Titane, alliage de titane		30	45			< 0.30 x ØD1	1 x ØD1	< 0.5 x ØD1	1 x ØD1
N	Alliage de cuivre / bonne usinabilité (laiton – bronze)		140	160			< 0.5 x ØD1	1 x ØD1	< 1 x ØD1	1 x ØD1
N	Alliage de cuivre / usinabilité difficile / Bronze à l'aluminium	(CuAlFe) (Ampco)	120	140	170	190	< 0.3 x ØD1	1 x ØD1	< 0.7 x ØD1	1 x ØD1
N	Alliage d'aluminium	Si < 8%	180	260	230	340	< 0.6 x ØD1	1 x ØD1	< 1.2 x ØD1	1 x ØD1
N	Fonte d'aluminium	Si > 8%	140	160	210	230	< 0.4 x ØD1	1 x ØD1	< 0.9 x ØD1	1 x ØD1
N	Graphite		140	160	200	220	< 0.6 x ØD1	1 x ØD1	< 0.9 x ØD1	1 x ØD1
N	Plastique		240	260	300	340	< 0.6 x ØD1	1 x ØD1	< 1.2 x ØD1	1 x ØD1
N	Or, argent		140	160	200	220	< 0.6 x ØD1	1 x ØD1	< 0.9 x ØD1	1 x ØD1



$$n \text{ [tr/min]} = \frac{Vc \text{ [m/min]} \times 1000}{\pi \times D_1 \text{ [mm]}}$$

$$Vf \text{ [mm/min]} = n \text{ [tr/min]} \times fz \text{ [mm]} \times Z$$

Avance par dent **fz [mm]**

$\emptyset D_1$ 0.30 - 1.00	$\emptyset D_1$ 1.00 - 1.50	$\emptyset D_1$ 1.50 - 3.00	$\emptyset D_1$ 3.00 - 5.00	$\emptyset D_1$ 5.00 - 7.00	$\emptyset D_1$ 7.00 - 10.00	$\emptyset D_1$ 10.00 - 14.00	$\emptyset D_1$ 14.00 - 16.00	$\emptyset D_1$ 16.00 - 20.00
0.006 - 0.015	0.012 - 0.020	0.016 - 0.04	0.02 - 0.06	0.03 - 0.09	0.04 - 0.11	0.05 - 0.11	0.06 - 0.12	0.07 - 0.14
0.006 - 0.015	0.012 - 0.020	0.016 - 0.04	0.02 - 0.06	0.03 - 0.09	0.04 - 0.11	0.05 - 0.11	0.06 - 0.12	0.07 - 0.13
0.006 - 0.015	0.012 - 0.020	0.016 - 0.04	0.02 - 0.06	0.03 - 0.09	0.04 - 0.12	0.05 - 0.14	0.07 - 0.16	0.08 - 0.20
0.006 - 0.015	0.012 - 0.020	0.016 - 0.04	0.02 - 0.06	0.03 - 0.09	0.04 - 0.11	0.05 - 0.11	0.06 - 0.12	0.07 - 0.13
0.006 - 0.015	0.012 - 0.020	0.016 - 0.04	0.02 - 0.06	0.03 - 0.09	0.04 - 0.11	0.05 - 0.11	0.06 - 0.12	0.07 - 0.13
0.006 - 0.015	0.012 - 0.020	0.016 - 0.04	0.02 - 0.06	0.03 - 0.09	0.04 - 0.11	0.05 - 0.11	0.06 - 0.12	0.07 - 0.13
0.006 - 0.015	0.012 - 0.020	0.016 - 0.04	0.02 - 0.06	0.03 - 0.09	0.04 - 0.11	0.05 - 0.11	0.06 - 0.12	0.07 - 0.13
0.006 - 0.015	0.012 - 0.020	0.016 - 0.04	0.02 - 0.06	0.03 - 0.09	0.04 - 0.11	0.05 - 0.11	0.06 - 0.12	0.07 - 0.13
	0.012 - 0.020	0.016 - 0.04	0.02 - 0.06	0.03 - 0.09	0.04 - 0.11	0.05 - 0.11	0.06 - 0.12	0.07 - 0.13
0.006 - 0.015	0.012 - 0.020	0.016 - 0.04	0.02 - 0.06	0.03 - 0.09	0.04 - 0.11	0.05 - 0.11	0.06 - 0.12	0.07 - 0.13
0.006 - 0.015	0.012 - 0.020	0.016 - 0.04	0.02 - 0.06	0.03 - 0.09	0.04 - 0.11	0.05 - 0.14	0.07 - 0.16	0.08 - 0.20
0.006 - 0.015	0.012 - 0.020	0.016 - 0.04	0.02 - 0.06	0.03 - 0.09	0.04 - 0.11	0.05 - 0.11	0.06 - 0.12	0.07 - 0.13
0.006 - 0.015	0.012 - 0.020	0.016 - 0.04	0.02 - 0.06	0.03 - 0.09	0.04 - 0.12	0.05 - 0.14	0.07 - 0.16	0.08 - 0.20
0.006 - 0.015	0.012 - 0.020	0.016 - 0.04	0.02 - 0.06	0.03 - 0.09	0.04 - 0.12	0.05 - 0.14	0.07 - 0.16	0.08 - 0.20
0.006 - 0.015	0.005 - 0.020	0.016 - 0.04	0.02 - 0.06	0.03 - 0.09	0.04 - 0.12	0.05 - 0.14	0.07 - 0.16	0.08 - 0.20
0.006 - 0.015	0.012 - 0.020	0.016 - 0.04	0.02 - 0.06	0.03 - 0.09	0.04 - 0.12	0.05 - 0.21	0.10 - 0.24	0.11 - 0.30
0.006 - 0.015	0.005 - 0.020	0.016 - 0.04	0.02 - 0.06	0.03 - 0.09	0.04 - 0.12	0.05 - 0.14	0.07 - 0.16	0.08 - 0.20



CONDITIONS DE COUPE - RAINURAGE

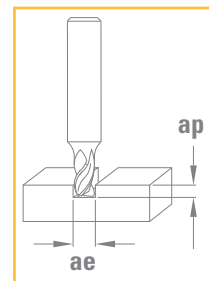

Matières à usiner			CUTINOX		ap
			Vc [m/min]		[mm]
P	Acier non allié / faiblement allié	< 600 N/mm ²	100	170	< 1 x ØD1
P	Acier non allié / faiblement allié	600 – 1500 N/mm ²	90	150	< 1 x ØD1
P	Acier de décolletage au plomb		120	180	< 1 x ØD1
P	Acier fortement allié	700 – 1500 N/mm ²	50	90	< 0.7 x ØD1
M	Acier inoxydable	400 – 700 N/mm ²	60	95	< 1 x ØD1
M	Acier inox. DUPLEX, acier austénitique inox. sans nickel	> 800 N/mm ²	50	90	< 0.7 x ØD1
K	Fonte grise / Fonte à graphite sphéroïdal perlitique	< 250 HB	140	180	< 1 x ØD1
K	Fonte alliée / Fonte à graphite sphéroïdal perlitique	> 250 HB	110	150	< 1 x ØD1
K	Fonte à graphite sphéroïdal ferritique / Fonte malléable		100	140	< 1 x ØD1
S	Super alliages / Acier inox. réfractaire	Inconel Nimonic Hastelloy	40	70	< 1 x ØD1
S	Titane, alliage de titane		20	40	< 0.3 x ØD1

Conditions de coupe basées sur l'huile entière.

Pour les aciers fortement alliés (>12% Chrome), les aciers inoxydables, les alliages de titane, réduire la vitesse de coupe de 20% si le lubrifiant est de l'huile en émulsion.

$$n \text{ [tr/min]} = \frac{Vc \text{ [m/min]} \times 1000}{\pi \times D_1 \text{ [mm]}}$$

$$Vf \text{ [mm/min]} = n \text{ [tr/min]} \times fz \text{ [mm]} \times Z$$

Avance par dent **fz [mm]**

$\emptyset D_1$ 3.00 - 4.00	$\emptyset D_1$ 4.00 - 6.00	$\emptyset D_1$ 6.00 - 8.00	$\emptyset D_1$ 8.00 - 10.00	$\emptyset D_1$ 10.00 - 12.00	$\emptyset D_1$ 12.00 - 16.00	$\emptyset D_1$ 16.00 - 20.00
0.010 - 0.017	0.013 - 0.035	0.020 - 0.055	0.023 - 0.070	0.029 - 0.080	0.035 - 0.090	0.046 - 0.100
0.009 - 0.015	0.012 - 0.030	0.017 - 0.045	0.020 - 0.060	0.025 - 0.070	0.030 - 0.080	0.040 - 0.090
0.013 - 0.023	0.017 - 0.045	0.026 - 0.068	0.030 - 0.090	0.038 - 0.105	0.045 - 0.120	0.040 - 0.135
0.007 - 0.013	0.010 - 0.025	0.015 - 0.040	0.017 - 0.050	0.021 - 0.060	0.026 - 0.070	0.034 - 0.075
0.009 - 0.015	0.012 - 0.030	0.017 - 0.045	0.020 - 0.060	0.025 - 0.070	0.030 - 0.080	0.040 - 0.090
0.007 - 0.013	0.010 - 0.025	0.015 - 0.040	0.017 - 0.050	0.021 - 0.060	0.026 - 0.070	0.034 - 0.075
0.013 - 0.023	0.017 - 0.045	0.026 - 0.068	0.030 - 0.090	0.038 - 0.105	0.045 - 0.120	0.040 - 0.135
0.012 - 0.020	0.016 - 0.040	0.023 - 0.060	0.027 - 0.080	0.034 - 0.095	0.041 - 0.110	0.036 - 0.120
0.012 - 0.020	0.016 - 0.040	0.023 - 0.060	0.027 - 0.080	0.034 - 0.095	0.041 - 0.110	0.036 - 0.120
0.010 - 0.017	0.013 - 0.035	0.020 - 0.055	0.023 - 0.070	0.029 - 0.080	0.035 - 0.090	0.046 - 0.100
0.004 - 0.010	0.005 - 0.013	0.007 - 0.020	0.010 - 0.023	0.013 - 0.026	0.013 - 0.033	0.020 - 0.039



CONDITIONS DE COUPE - CONTOURNAGE

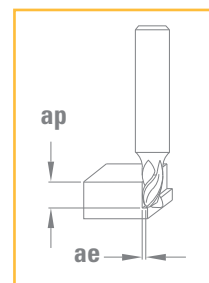

Matières à usiner			CUTINOX		ap [mm]	ae [mm]
			Vc [m/min]			
P	Acier non allié / faiblement allié	< 600 N/mm ²	160	200	< 1 x ØD1	< 0.6 x ØD1
P	Acier non allié / faiblement allié	600 – 1500 N/mm ²	130	170	< 1 x ØD1	< 0.6 x ØD1
P	Acier de décolletage au plomb		160	200	< 1 x ØD1	< 0.6 x ØD1
P	Acier fortement allié	700 – 1500 N/mm ²	70	100	< 1 x ØD1	< 0.5 x ØD1
M	Acier inoxydable	400 – 700 N/mm ²	80	110	< 1 x ØD1	< 0.5 x ØD1
M	Acier inox. DUPLEX, acier austénitique inox. sans nickel	> 800 N/mm ²	70	100	< 1 x ØD1	< 0.5 x ØD1
K	Fonte grise / Fonte à graphite sphéroïdal perlitique	< 250 HB	160	200	< 1 x ØD1	< 0.6 x ØD1
K	Fonte alliée / Fonte à graphite sphéroïdal perlitique	> 250 HB	130	170	< 1 x ØD1	< 0.6 x ØD1
K	Fonte à graphite sphéroïdal ferritique / Fonte malléable		110	150	< 1 x ØD1	< 0.6 x ØD1
S	Super alliages / Acier inox. réfractaire	Inconel Nimonic Hastelloy	40	70	< 1 x ØD1	< 0.6 x ØD1
S	Titane, alliage de titane		20	50	< 1 x ØD1	< 0.3 x ØD1

Conditions de coupe basées sur l'huile entière.

Pour les aciers fortement alliés (>12% Chrome),
les aciers inoxydables, les alliages de titane,
réduire la vitesse de coupe de 20% si le lubrifiant
est de l'huile en émulsion.

Si $ae < 0.1 \times D$, augmenter VC et fz de 25%.

$$n \text{ [tr/min]} = \frac{Vc \text{ [m/min]} \times 1000}{\pi \times D_1 \text{ [mm]}}$$

$$Vf \text{ [mm/min]} = n \text{ [tr/min]} \times fz \text{ [mm]} \times Z$$

Avance par dent **fz [mm]**

$\emptyset D_1$ 3.00 - 4.00	$\emptyset D_1$ 4.00 - 6.00	$\emptyset D_1$ 6.00 - 8.00	$\emptyset D_1$ 8.00 - 10.00	$\emptyset D_1$ 10.00 - 12.00	$\emptyset D_1$ 12.00 - 16.00	$\emptyset D_1$ 16.00 - 20.00
0.019 - 0.045	0.029 - 0.070	0.040 - 0.100	0.052 - 0.115	0.057 - 0.130	0.063 - 0.155	0.086 - 0.185
0.017 - 0.040	0.023 - 0.065	0.035 - 0.085	0.046 - 0.105	0.052 - 0.115	0.058 - 0.135	0.075 - 0.165
0.029 - 0.065	0.035 - 0.100	0.052 - 0.130	0.069 - 0.155	0.081 - 0.175	0.086 - 0.210	0.115 - 0.250
0.014 - 0.035	0.017 - 0.050	0.029 - 0.070	0.040 - 0.085	0.046 - 0.090	0.052 - 0.110	0.063 - 0.130
0.017 - 0.040	0.023 - 0.065	0.035 - 0.085	0.046 - 0.105	0.052 - 0.115	0.058 - 0.135	0.075 - 0.165
0.014 - 0.035	0.017 - 0.050	0.029 - 0.070	0.040 - 0.085	0.046 - 0.090	0.052 - 0.110	0.063 - 0.130
0.029 - 0.065	0.035 - 0.100	0.052 - 0.130	0.069 - 0.155	0.081 - 0.175	0.086 - 0.210	0.115 - 0.250
0.024 - 0.055	0.029 - 0.085	0.044 - 0.111	0.059 - 0.132	0.068 - 0.149	0.073 - 0.179	0.098 - 0.213
0.024 - 0.055	0.029 - 0.085	0.044 - 0.111	0.059 - 0.132	0.068 - 0.149	0.073 - 0.179	0.098 - 0.213
0.019 - 0.045	0.029 - 0.070	0.040 - 0.100	0.052 - 0.115	0.057 - 0.130	0.063 - 0.155	0.086 - 0.185
0.007 - 0.017	0.009 - 0.025	0.012 - 0.035	0.017 - 0.040	0.023 - 0.050	0.026 - 0.060	0.032 - 0.070



CONDITIONS DE COUPE - RAINURAGE

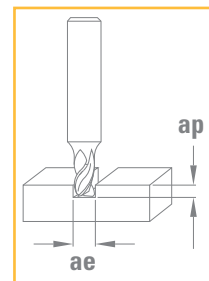

Matières à usiner			CUTINOX		ap
			Vc [m/min]		[mm]
P	Acier non allié / faiblement allié	< 600 N/mm ²	100	170	< 1 x ØD1
P	Acier non allié / faiblement allié	600 – 1500 N/mm ²	90	150	< 1 x ØD1
P	Acier de décolletage au plomb		120	180	< 1 x ØD1
P	Acier fortement allié	700 – 1500 N/mm ²	50	90	< 0.7 x ØD1
M	Acier inoxydable	400 – 700 N/mm ²	60	95	< 1 x ØD1
M	Acier inox. DUPLEX, acier austénitique inox. sans nickel	> 800 N/mm ²	50	90	< 0.7 x ØD1
K	Fonte grise / Fonte à graphite sphéroïdal perlitique	< 250 HB	140	180	< 1 x ØD1
K	Fonte alliée / Fonte à graphite sphéroïdal perlitique	> 250 HB	110	150	< 1 x ØD1
K	Fonte à graphite sphéroïdal ferritique / Fonte malléable		100	140	< 1 x ØD1
S	Super alliages / Acier inox. réfractaire	Inconel Nimonic Hastelloy	30	55	< 1 x ØD1
S	Titane, alliage de titane		20	50	< 0.3 x ØD1

Conditions de coupe basées sur l'huile entière.

Pour les aciers fortement alliés (>12% Chrome), les aciers inoxydables, les alliages de titane, réduire la vitesse de coupe de 20% si le lubrifiant est de l'huile en émulsion.



$$n \text{ [tr/min]} = \frac{Vc \text{ [m/min]} \times 1000}{\pi \times D_1 \text{ [mm]}}$$

$$Vf \text{ [mm/min]} = n \text{ [tr/min]} \times fz \text{ [mm]} \times Z$$

Avance par dent **fz [mm]**

$\emptyset D_1$ 1.50 - 3.00	$\emptyset D_1$ 3.00 - 4.00	$\emptyset D_1$ 4.00 - 6.00	$\emptyset D_1$ 6.00 - 8.00	$\emptyset D_1$ 8.00 - 10.00	$\emptyset D_1$ 10.00 - 12.00	$\emptyset D_1$ 12.00 - 16.00	$\emptyset D_1$ 16.00 - 20.00
0.005 - 0.010	0.008 - 0.020	0.011 - 0.030	0.017 - 0.040	0.022 - 0.050	0.025 - 0.055	0.030 - 0.065	0.040 - 0.085
0.005 - 0.010	0.008 - 0.018	0.010 - 0.025	0.015 - 0.035	0.020 - 0.045	0.023 - 0.050	0.025 - 0.060	0.035 - 0.075
0.010 - 0.020	0.013 - 0.030	0.015 - 0.045	0.023 - 0.050	0.025 - 0.070	0.030 - 0.075	0.032 - 0.080	0.035 - 0.110
0.004 - 0.010	0.006 - 0.015	0.008 - 0.020	0.013 - 0.030	0.018 - 0.035	0.020 - 0.040	0.025 - 0.050	0.030 - 0.060
0.005 - 0.010	0.008 - 0.018	0.010 - 0.025	0.015 - 0.035	0.020 - 0.045	0.023 - 0.050	0.025 - 0.060	0.035 - 0.075
0.004 - 0.010	0.006 - 0.015	0.008 - 0.020	0.013 - 0.030	0.018 - 0.035	0.020 - 0.040	0.025 - 0.050	0.030 - 0.060
0.010 - 0.020	0.013 - 0.030	0.015 - 0.045	0.023 - 0.050	0.025 - 0.070	0.030 - 0.075	0.032 - 0.080	0.035 - 0.110
0.008 - 0.015	0.011 - 0.025	0.013 - 0.040	0.019 - 0.045	0.021 - 0.060	0.026 - 0.065	0.027 - 0.070	0.030 - 0.095
0.008 - 0.015	0.011 - 0.025	0.013 - 0.040	0.019 - 0.045	0.021 - 0.060	0.026 - 0.065	0.027 - 0.070	0.030 - 0.095
0.005 - 0.010	0.008 - 0.020	0.011 - 0.030	0.017 - 0.040	0.022 - 0.050	0.025 - 0.055	0.030 - 0.065	0.040 - 0.085
0.001 - 0.005	0.003 - 0.008	0.004 - 0.010	0.005 - 0.015	0.008 - 0.018	0.010 - 0.020	0.010 - 0.025	0.015 - 0.030



CONDITIONS DE COUPE - CONTOURNAGE

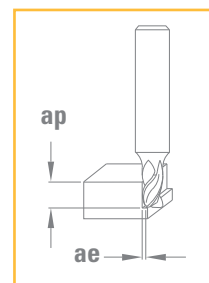

Matières à usiner			CUTINOX		ap [mm]	ae [mm]
			Vc [m/min]			
P	Acier non allié / faiblement allié	< 600 N/mm ²	160	200	< 2 x ØD1	< 0.4 x ØD1
P	Acier non allié / faiblement allié	600 – 1500 N/mm ²	130	170	< 2 x ØD1	< 0.3 x ØD1
P	Acier de décolletage au plomb		160	200	< 2 x ØD1	< 0.4 x ØD1
P	Acier fortement allié	700 – 1500 N/mm ²	70	100	< 2 x ØD1	< 0.3 x ØD1
M	Acier inoxydable	400 – 700 N/mm ²	80	110	< 2 x ØD1	< 0.3 x ØD1
M	Acier inox. DUPLEX, acier austénitique inox. sans nickel	> 800 N/mm ²	70	100	< 2 x ØD1	< 0.3 x ØD1
K	Fonte grise / Fonte à graphite sphéroïdal perlitique	< 250 HB	160	200	< 2 x ØD1	< 0.4 x ØD1
K	Fonte alliée / Fonte à graphite sphéroïdal perlitique	> 250 HB	130	170	< 2 x ØD1	< 0.4 x ØD1
K	Fonte à graphite sphéroïdal ferritique / Fonte malléable		110	150	< 2 x ØD1	< 0.3 x ØD1
S	Super alliages / Acier inox. réfractaire	Inconel Nimonic Hastelloy	20	50	< 2 x ØD1	< 0.2 x ØD1
S	Titane, alliage de titane		40	70	< 2 x ØD1	< 0.3 x ØD1

Conditions de coupe basées sur l'huile entière.

Pour les aciers fortement alliés (>12% Chrome), les aciers inoxydables, les alliages de titane, réduire la vitesse de coupe de 20% si le lubrifiant est de l'huile en émulsion.

Si ae < 0.1 x D, augmenter VC et fz de 25%.



$$n \text{ [tr/min]} = \frac{Vc \text{ [m/min]} \times 1000}{\pi \times D_1 \text{ [mm]}}$$

$$Vf \text{ [mm/min]} = n \text{ [tr/min]} \times fz \text{ [mm]} \times Z$$

Avance par dent **fz [mm]**

$\emptyset D_1$ 1.50 - 3.00	$\emptyset D_1$ 3.00 - 4.00	$\emptyset D_1$ 4.00 - 6.00	$\emptyset D_1$ 6.00 - 8.00	$\emptyset D_1$ 8.00 - 10.00	$\emptyset D_1$ 10.00 - 12.00	$\emptyset D_1$ 12.00 - 16.00	$\emptyset D_1$ 16.00 - 20.00
0.015 - 0.030	0.019 - 0.040	0.025 - 0.060	0.035 - 0.085	0.045 - 0.100	0.050 - 0.110	0.055 - 0.135	0.075 - 0.160
0.011 - 0.025	0.015 - 0.035	0.020 - 0.055	0.030 - 0.075	0.040 - 0.090	0.045 - 0.100	0.050 - 0.120	0.068 - 0.144
0.021 - 0.045	0.025 - 0.055	0.030 - 0.085	0.045 - 0.115	0.060 - 0.135	0.070 - 0.150	0.075 - 0.180	0.100 - 0.220
0.008 - 0.020	0.012 - 0.030	0.015 - 0.045	0.025 - 0.060	0.035 - 0.075	0.040 - 0.080	0.045 - 0.095	0.055 - 0.115
0.011 - 0.025	0.015 - 0.035	0.020 - 0.055	0.030 - 0.075	0.040 - 0.090	0.045 - 0.100	0.050 - 0.120	0.065 - 0.145
0.008 - 0.020	0.012 - 0.030	0.015 - 0.045	0.025 - 0.060	0.035 - 0.075	0.040 - 0.080	0.045 - 0.095	0.055 - 0.115
0.021 - 0.045	0.025 - 0.055	0.030 - 0.085	0.045 - 0.115	0.060 - 0.135	0.070 - 0.150	0.075 - 0.180	0.100 - 0.220
0.017 - 0.037	0.021 - 0.047	0.026 - 0.072	0.038 - 0.098	0.051 - 0.115	0.060 - 0.128	0.064 - 0.153	0.085 - 0.187
0.017 - 0.037	0.021 - 0.047	0.026 - 0.072	0.038 - 0.098	0.051 - 0.115	0.060 - 0.128	0.064 - 0.153	0.085 - 0.187
0.003 - 0.007	0.006 - 0.015	0.008 - 0.020	0.010 - 0.030	0.015 - 0.035	0.020 - 0.040	0.023 - 0.050	0.028 - 0.060
0.013 - 0.030	0.017 - 0.040	0.025 - 0.060	0.035 - 0.085	0.045 - 0.100	0.050 - 0.110	0.055 - 0.135	0.075 - 0.160



CONDITIONS DE COUPE

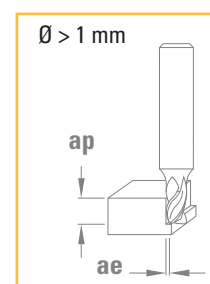
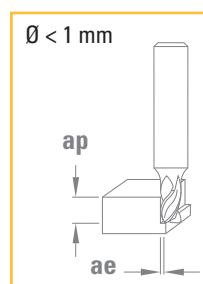

Matières à usiner			CARBURE		TiAIN		$\varnothing < 1 \text{ mm}$		$\varnothing > 1 \text{ mm}$	
			Vc [m/min]	Vc [m/min]	Vc [m/min]	Vc [m/min]	ap [mm]	ae [mm]	ap [mm]	ae [mm]
P	Acier non allié / faiblement allié	< 600 N/mm ²	70	100	90	110	< 1 x ØD1	< 0.2 x ØD1	< 1 x ØD1	< 0.3 x ØD1
P	Acier non allié / faiblement allié	600 – 1500 N/mm ²			70	90	< 1 x ØD1	< 0.10 x ØD1	< 1 x ØD1	< 0.2 x ØD1
P	Acier de décolletage au plomb		70	100			< 1.5 x ØD1	< 0.2 x ØD1	< 1.5 x ØD1	< 0.3 x ØD1
P	Acier fortement allié	700 – 1500 N/mm ²			40	55	< 1 x ØD1	< 0.10 x ØD1	< 1 x ØD1	< 0.2 x ØD1
M	Acier inoxydable	400 – 700 N/mm ²			70	90	< 1 x ØD1	< 0.1 x ØD1	< 1 x ØD1	< 0.3 x ØD1
M	Acier inox. DUPLEX, acier austénitique inox. sans nickel	> 800 N/mm ²			40	55	< 1 x ØD1	< 0.10 x ØD1	< 1 x ØD1	< 0.2 x ØD1
K	Fonte grise / Fonte à graphite sphéroïdal perlitique	< 250 HB	70	100	90	110	< 1 x ØD1	< 0.1 x ØD1	< 1 x ØD1	< 0.3 x ØD1
K	Fonte allié / Fonte à graphite sphéroïdal perlitique	> 250 HB	40	70	70	90	< 1 x ØD1	< 0.1 x ØD1	< 1 x ØD1	< 0.3 x ØD1
K	Fonte à graphite sphéroïdal ferritique / Fonte malléable		70	100	90	110	< 1 x ØD1	< 0.1 x ØD1	< 1 x ØD1	< 0.3 x ØD1
S	Titane, alliage de titane		30	45			< 1 x ØD1	< 0.1 x ØD1	< 1 x ØD1	< 0.3 x ØD1
N	Alliage de cuivre / bonne usinabilité (laiton – bronze)		140	160			< 1.5 x ØD1	< 0.2 x ØD1	< 1.5 x ØD1	< 0.3 x ØD1
N	Alliage de cuivre / usinabilité difficile / Bronze à l'aluminium (CuAlFe) (Ampco)		120	140	170	190	< 1 x ØD1	< 0.1 x ØD1	< 1 x ØD1	< 0.2 x ØD1
N	Alliage d'aluminium	Si < 8%	180	220	230	270	< 1.5 x ØD1	< 0.2 x ØD1	< 1.5 x ØD1	< 0.3 x ØD1
N	Fonte d'aluminium	Si > 8%	140	160	210	230	< 1.5 x ØD1	< 0.2 x ØD1	< 1.5 x ØD1	< 0.3 x ØD1
N	Plastique		240	260	300	340	< 1.5 x ØD1	< 0.2 x ØD1	< 1.5 x ØD1	< 0.3 x ØD1
N	Or, argent		140	160	200	220	< 1.5 x ØD1	< 0.2 x ØD1	< 1.5 x ØD1	< 0.3 x ØD1

DIXI 7244 DIAMANT

CONDITIONS DE COUPE

Matières à usiner		DIAMANT		ap [mm]	ae [mm]
		Vc [m/min]	Vc [m/min]		
N	Graphite	200	300	< 1.5 x ØD1	< 0.2 x ØD1



$$n \text{ [tr/min]} = \frac{Vc \text{ [m/min]} \times 1000}{\pi \times D_1 \text{ [mm]}}$$

$$Vf \text{ [mm/min]} = n \text{ [tr/min]} \times fz \text{ [mm]} \times Z$$

Avance par dent **fz [mm]**

Ø D ₁ 0.40 - 1.00	Ø D ₁ 1.00 - 1.50	Ø D ₁ 1.50 - 3.00	Ø D ₁ 3.00 - 5.00	Ø D ₁ 5.00 - 7.00	Ø D ₁ 7.00 - 10.00	Ø D ₁ 10.00 - 14.00	Ø D ₁ 14.00 - 16.00	Ø D ₁ 16.00 - 20.00
0.006 - 0.015	0.012 - 0.020	0.016 - 0.04	0.02 - 0.06	0.03 - 0.09	0.04 - 0.12	0.05 - 0.10	0.06 - 0.11	0.07 - 0.14
0.006 - 0.015	0.012 - 0.020	0.016 - 0.04	0.02 - 0.06	0.03 - 0.09	0.04 - 0.12	0.05 - 0.07	0.06 - 0.08	0.07 - 0.10
0.006 - 0.015	0.012 - 0.020	0.016 - 0.04	0.02 - 0.06	0.03 - 0.09	0.04 - 0.12	0.05 - 0.14	0.07 - 0.16	0.08 - 0.20
0.006 - 0.015	0.012 - 0.020	0.016 - 0.04	0.02 - 0.06	0.03 - 0.09	0.04 - 0.12	0.05 - 0.13	0.06 - 0.14	0.07 - 0.15
0.006 - 0.015	0.012 - 0.020	0.016 - 0.04	0.02 - 0.06	0.03 - 0.09	0.04 - 0.12	0.05 - 0.13	0.06 - 0.14	0.07 - 0.15
0.006 - 0.015	0.012 - 0.020	0.016 - 0.04	0.02 - 0.06	0.03 - 0.09	0.04 - 0.12	0.05 - 0.13	0.06 - 0.14	0.07 - 0.15
0.006 - 0.015	0.012 - 0.020	0.016 - 0.04	0.02 - 0.06	0.03 - 0.09	0.04 - 0.12	0.05 - 0.13	0.06 - 0.14	0.07 - 0.15
0.006 - 0.015	0.012 - 0.020	0.016 - 0.04	0.02 - 0.06	0.03 - 0.09	0.04 - 0.12	0.05 - 0.13	0.06 - 0.14	0.07 - 0.15
0.006 - 0.015	0.012 - 0.020	0.016 - 0.04	0.02 - 0.06	0.03 - 0.09	0.04 - 0.12	0.05 - 0.14	0.07 - 0.16	0.08 - 0.20
0.006 - 0.015	0.012 - 0.020	0.016 - 0.04	0.02 - 0.06	0.03 - 0.09	0.04 - 0.12	0.05 - 0.07	0.06 - 0.08	0.07 - 0.10
0.006 - 0.015	0.012 - 0.020	0.016 - 0.04	0.02 - 0.06	0.03 - 0.09	0.04 - 0.12	0.05 - 0.14	0.07 - 0.16	0.08 - 0.20
0.006 - 0.015	0.012 - 0.020	0.016 - 0.04	0.02 - 0.06	0.03 - 0.09	0.04 - 0.12	0.05 - 0.14	0.07 - 0.16	0.08 - 0.20
0.006 - 0.015	0.012 - 0.020	0.016 - 0.04	0.02 - 0.06	0.03 - 0.09	0.04 - 0.12	0.05 - 0.14	0.07 - 0.16	0.08 - 0.20
0.006 - 0.015	0.012 - 0.020	0.016 - 0.04	0.02 - 0.06	0.03 - 0.09	0.04 - 0.12	0.05 - 0.14	0.07 - 0.16	0.08 - 0.20
0.006 - 0.015	0.005 - 0.020	0.016 - 0.04	0.02 - 0.06	0.03 - 0.09	0.04 - 0.12	0.05 - 0.14	0.07 - 0.16	0.08 - 0.20

Avance par dent

Ø D ₁ 0.40 - 1.00	Ø D ₁ 1.00 - 1.50	Ø D ₁ 1.50 - 3.00	Ø D ₁ 3.00 - 5.00	Ø D ₁ 5.00 - 7.00	Ø D ₁ 7.00 - 10.00	Ø D ₁ 10.00 - 14.00	Ø D ₁ 14.00 - 16.00	Ø D ₁ 16.00 - 20.00
0.006 - 0.015	0.012 - 0.020	0.016 - 0.04	0.02 - 0.06	0.03 - 0.09	0.04 - 0.12	0.05 - 0.14	0.07 - 0.16	0.08 - 0.20



CONDITIONS DE COUPE

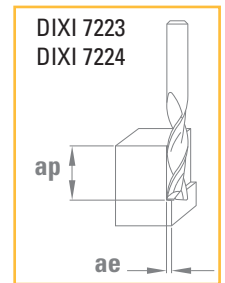
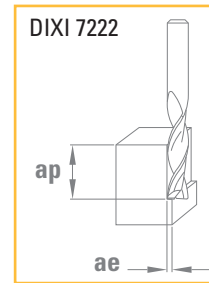

Matières à usiner

			CARBURE		TiAlN		ap [mm]		ae [mm]	
			Vc [m/min]	Vc [m/min]	Vc [m/min]	Vc [m/min]	3 x ØD1	< 0.30 x ØD1	3 x ØD1	< 0.20 x ØD1
P	Acier non allié / faiblement allié	< 600 N/mm ²	45	50	50	60	3 x ØD1	< 0.30 x ØD1	3 x ØD1	< 0.20 x ØD1
P	Acier non allié / faiblement allié	600 – 1500 N/mm ²			35	45	3 x ØD1	< 0.20 x ØD1	3 x ØD1	< 0.10 x ØD1
P	Acier de décolletage au plomb		45	50			3 x ØD1	< 0.30 x ØD1	3 x ØD1	< 0.20 x ØD1
P	Acier fortement allié	700 – 1500 N/mm ²			30	45	3 x ØD1	< 0.15 x ØD1	3 x ØD1	< 0.07 x ØD1
M	Acier inoxydable	400 – 700 N/mm ²			35	45	3 x ØD1	< 0.20 x ØD1	3 x ØD1	< 0.10 x ØD1
M	Acier inox. DUPLEX, acier austénitique inox. sans nickel	> 800 N/mm ²			30	45	3 x ØD1	< 0.30 x ØD1	3 x ØD1	< 0.07 x ØD1
K	Fonte grise / Fonte à graphite sphéroïdal perlitique	< 250 HB	25	35	35	45	3 x ØD1	< 0.15 x ØD1	3 x ØD1	< 0.20 x ØD1
K	Fonte alliée / Fonte à graphite sphéroïdal perlitique	> 250 HB	25	35	35	45	3 x ØD1	< 0.30 x ØD1	3 x ØD1	< 0.07 x ØD1
K	Fonte à graphite sphéroïdal ferritique / Fonte malléable		25	35	35	45	3 x ØD1	< 0.10 x ØD1	3 x ØD1	< 0.20 x ØD1
S	Titane, alliage de titane		15	25			3 x ØD1	< 0.15 x ØD1	3 x ØD1	< 0.03 x ØD1
N	Alliage de cuivre / bonne usinabilité (laiton – bronze)		80	100			3 x ØD1	< 0.30 x ØD1	3 x ØD1	< 0.20 x ØD1
N	Alliage de cuivre / usinabilité difficile / Bronze à l'aluminium (CuAlFe)		60	80	80	100	3 x ØD1	< 0.30 x ØD1	3 x ØD1	< 0.20 x ØD1
N	Alliage d'aluminium	Si < 8%	80	110	100	130	3 x ØD1	< 0.40 x ØD1	3 x ØD1	< 0.30 x ØD1
N	Fonte d'aluminium	Si > 8%	80	100	100	120	3 x ØD1	< 0.40 x ØD1	3 x ØD1	< 0.30 x ØD1
N	Plastique		90	110	110	130	3 x ØD1	< 0.40 x ØD1	3 x ØD1	< 0.30 x ØD1
N	Or, argent		80	100	100	120	3 x ØD1	< 0.40 x ØD1	3 x ØD1	< 0.30 x ØD1

DIXI 7222 - 7223 - 7224 DIAMANT

CONDITIONS DE COUPE

Matières à usiner

		DIAMANT		ap [mm]		ae [mm]	
		Vc [m/min]	Vc [m/min]	3 x ØD1	< 0.30 x ØD1	3 x ØD1	< 0.30 x ØD1
N	Graphite	200	300	3 x ØD1	< 0.30 x ØD1	3 x ØD1	< 0.30 x ØD1



$$n \text{ [tr/min]} = \frac{Vc \text{ [m/min]} \times 1000}{\pi \times D_1 \text{ [mm]}}$$

$$Vf \text{ [mm/min]} = n \text{ [tr/min]} \times fz \text{ [mm]} \times Z$$

Avance par dent **fz [mm]**

Ø D ₁ 3.00 - 4.00	Ø D ₁ 4.00 - 5.00	Ø D ₁ 5.00 - 6.00	Ø D ₁ 6.00 - 7.00	Ø D ₁ 7.00 - 8.00	Ø D ₁ 8.00 - 10.00	Ø D ₁ 10.00 - 12.00	Ø D ₁ 12.00 - 14.00	Ø D ₁ 14.00 - 16.00	Ø D ₁ 16.00 - 20.00
0.006 - 0.01	0.008 - 0.02	0.010 - 0.02	0.012 - 0.02	0.014 - 0.03	0.018 - 0.04	0.02 - 0.04	0.02 - 0.05	0.03 - 0.06	0.03 - 0.07
0.005 - 0.01	0.006 - 0.01	0.008 - 0.02	0.009 - 0.02	0.011 - 0.02	0.014 - 0.03	0.02 - 0.03	0.02 - 0.04	0.02 - 0.04	0.02 - 0.05
0.008 - 0.02	0.010 - 0.03	0.013 - 0.03	0.015 - 0.04	0.018 - 0.04	0.023 - 0.05	0.03 - 0.06	0.03 - 0.07	0.04 - 0.08	0.04 - 0.10
0.005 - 0.01	0.006 - 0.01	0.008 - 0.02	0.009 - 0.02	0.011 - 0.02	0.014 - 0.03	0.02 - 0.03	0.02 - 0.04	0.02 - 0.04	0.02 - 0.05
0.005 - 0.01	0.006 - 0.01	0.008 - 0.02	0.009 - 0.02	0.011 - 0.02	0.014 - 0.03	0.02 - 0.03	0.02 - 0.04	0.02 - 0.04	0.02 - 0.05
0.005 - 0.01	0.006 - 0.01	0.008 - 0.02	0.009 - 0.02	0.011 - 0.02	0.014 - 0.03	0.02 - 0.03	0.02 - 0.04	0.02 - 0.04	0.02 - 0.05
0.006 - 0.01	0.008 - 0.02	0.010 - 0.02	0.012 - 0.02	0.014 - 0.03	0.018 - 0.04	0.02 - 0.04	0.02 - 0.05	0.03 - 0.06	0.03 - 0.07
0.005 - 0.01	0.006 - 0.01	0.008 - 0.02	0.009 - 0.02	0.011 - 0.02	0.014 - 0.03	0.02 - 0.03	0.02 - 0.04	0.02 - 0.04	0.02 - 0.05
0.006 - 0.01	0.008 - 0.02	0.010 - 0.02	0.012 - 0.02	0.014 - 0.03	0.018 - 0.04	0.02 - 0.04	0.02 - 0.05	0.03 - 0.06	0.03 - 0.07
0.005 - 0.01	0.006 - 0.01	0.008 - 0.02	0.009 - 0.02	0.011 - 0.02	0.014 - 0.03	0.02 - 0.03	0.02 - 0.04	0.02 - 0.04	0.02 - 0.05
0.008 - 0.02	0.010 - 0.03	0.013 - 0.03	0.015 - 0.04	0.018 - 0.04	0.023 - 0.05	0.03 - 0.06	0.03 - 0.07	0.04 - 0.08	0.04 - 0.10
0.005 - 0.01	0.006 - 0.01	0.008 - 0.02	0.009 - 0.02	0.011 - 0.02	0.014 - 0.03	0.02 - 0.03	0.02 - 0.04	0.02 - 0.04	0.02 - 0.05
0.008 - 0.02	0.010 - 0.03	0.013 - 0.03	0.015 - 0.04	0.018 - 0.04	0.023 - 0.05	0.03 - 0.06	0.03 - 0.07	0.04 - 0.08	0.04 - 0.10
0.008 - 0.02	0.010 - 0.03	0.013 - 0.03	0.015 - 0.04	0.018 - 0.04	0.023 - 0.05	0.03 - 0.06	0.03 - 0.07	0.04 - 0.08	0.04 - 0.10
0.011 - 0.03	0.014 - 0.04	0.018 - 0.05	0.021 - 0.05	0.025 - 0.06	0.032 - 0.08	0.04 - 0.09	0.04 - 0.11	0.05 - 0.12	0.06 - 0.15
0.008 - 0.02	0.010 - 0.03	0.013 - 0.03	0.015 - 0.04	0.018 - 0.04	0.023 - 0.05	0.03 - 0.06	0.03 - 0.07	0.04 - 0.08	0.04 - 0.10

L'avance en plongée (V_{fp}) d'une fraise Z = 2 (perçage) doit être réduite de 40 à 80 % en fonction de la matière à usiner.

Avance par dent

Ø D ₁ 3.00 - 4.00	Ø D ₁ 4.00 - 5.00	Ø D ₁ 5.00 - 6.00	Ø D ₁ 6.00 - 7.00	Ø D ₁ 7.00 - 8.00	Ø D ₁ 8.00 - 10.00	Ø D ₁ 10.00 - 12.00	Ø D ₁ 12.00 - 14.00	Ø D ₁ 14.00 - 16.00	Ø D ₁ 16.00 - 20.00
0.011 - 0.03	0.014 - 0.04	0.018 - 0.05	0.021 - 0.05	0.025 - 0.06	0.032 - 0.08	0.04 - 0.09	0.04 - 0.11	0.05 - 0.12	0.06 - 0.15



CONDITIONS DE COUPE

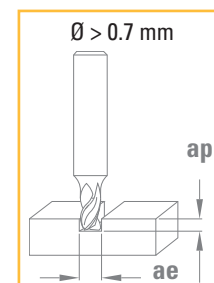
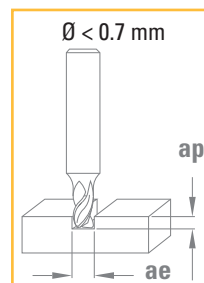

Matières à usiner

			CARBURE		CUTINOX		$\varnothing < 0.7 \text{ mm}$		$\varnothing > 0.7 \text{ mm}$	
			Vc [m/min]	Vc [m/min]	Vc [m/min]	Vc [m/min]	ap [mm]	ae [mm]	ap [mm]	ae [mm]
P	Acier non allié / faiblement allié	< 600 N/mm ²	50	80	80	120	0.8 x ØD1	< 1 x ØD1	1 x ØD1	< 1 x ØD1
P	Acier non allié / faiblement allié	600 – 1500 N/mm ²	30	60	70	100	0.6 x ØD1	< 1 x ØD1	1 x ØD1	< 1 x ØD1
P	Acier de décolletage au plomb		80	120	100	180	1 x ØD1	< 1 x ØD1	1 x ØD1	< 1 x ØD1
P	Acier fortement allié	700 – 1500 N/mm ²	30	50	40	70	0.5 x ØD1	< 1 x ØD1	0.8 x ØD1	< 1 x ØD1
M	Acier inoxydable	400 – 700 N/mm ²	40	60	60	90	0.5 x ØD1	< 1 x ØD1	0.8 x ØD1	< 1 x ØD1
M	Acier inox. DUPLEX, acier austénitique inox. sans nickel	> 800 N/mm ²	20	40	30	60	0.4 x ØD1	< 1 x ØD1	0.7 x ØD1	< 1 x ØD1
K	Fonte grise / Fonte à graphite sphéroïdal perlitique	< 250 HB	100	150	150	200	1 x ØD1	< 1 x ØD1	1 x ØD1	< 1 x ØD1
K	Fonte allié / Fonte à graphite sphéroïdal perlitique	> 250 HB	50	80	60	100	0.8 x ØD1	< 1 x ØD1	1 x ØD1	< 1 x ØD1
K	Fonte à graphite sphéroïdal ferritique / Fonte malléable		50	80	60	90	0.8 x ØD1	< 1 x ØD1	1 x ØD1	< 1 x ØD1
S	Super alliages / Acier inox. réfractaire	Inconel Nimonic Hastelloy	10	20	20	40	0.2 x ØD1	< 1 x ØD1	0.4 x ØD1	< 1 x ØD1
S	Titane, alliage de titane		30	60	40	70	0.8 x ØD1	< 1 x ØD1	1 x ØD1	< 1 x ØD1
N	Alliage de cuivre / bonne usinabilité (laiton – bronze)		150	250	100	250	1 x ØD1	< 1 x ØD1	1 x ØD1	< 1 x ØD1
N	Alliage de cuivre / usinabilité difficile / Bronze à l'aluminium	(CuAlFe) (Ampco)	80	150	80	150	0.8 x ØD1	< 1 x ØD1	1 x ØD1	< 1 x ØD1
N	Alliage d'aluminium	Si < 8%	150	300	150	300	1 x ØD1	< 1 x ØD1	1 x ØD1	< 1 x ØD1
N	Fonte d'aluminium	Si > 8%	100	150	150	250	3 x ØD1	< 1 x ØD1	1 x ØD1	< 1 x ØD1
N	Plastique		100	150	100	150	3 x ØD1	< 1 x ØD1	1 x ØD1	< 1 x ØD1
N	Or, argent		100	150	100	150	1 x ØD1	< 1 x ØD1	1 x ØD1	< 1 x ØD1

Les valeurs n et Vf sont indicatives et devront être ajustées en fonction de la longueur L₂ de l'outil



$$n \text{ [tr/min]} = \frac{Vc \text{ [m/min]} \times 1000}{\pi \times D_1 \text{ [mm]}}$$

$$Vf \text{ [mm/min]} = n \text{ [tr/min]} \times fz \text{ [mm]} \times Z$$

Avance par dent **fz [mm]**

$\emptyset D_1$ 0.30 - 0.50	$\emptyset D_1$ 0.60 - 0.90	$\emptyset D_1$ 1.00 - 2.00	$\emptyset D_1$ 2.00 - 4.00	$\emptyset D_1$ 4.00 - 6.00	$\emptyset D_1$ 6.00 - 8.00	$\emptyset D_1$ 80.00 - 10.00
0.002 - 0.005	0.003 - 0.012	0.005 - 0.025	0.01 - 0.06	0.02 - 0.08	0.03 - 0.12	0.04 - 0.15
0.001 - 0.004	0.003 - 0.01	0.005 - 0.02	0.01 - 0.04	0.02 - 0.06	0.03 - 0.08	0.04 - 0.10
0.002 - 0.008	0.004 - 0.016	0.006 - 0.03	0.015 - 0.07	0.015 - 0.09	0.04 - 0.15	0.1 - 0.20
0.001 - 0.003	0.002 - 0.01	0.003 - 0.015	0.008 - 0.03	0.03 - 0.04	0.03 - 0.06	0.04 - 0.08
0.001 - 0.003	0.002 - 0.01	0.003 - 0.013	0.008 - 0.03	0.013 - 0.04	0.03 - 0.06	0.04 - 0.08
0.001 - 0.003	0.002 - 0.008	0.003 - 0.01	0.004 - 0.02	0.008 - 0.03	0.01 - 0.04	0.02 - 0.05
0.002 - 0.005	0.003 - 0.012	0.005 - 0.025	0.01 - 0.06	0.02 - 0.08	0.03 - 0.12	0.1 - 0.20
0.001 - 0.002	0.003 - 0.015	0.005 - 0.02	0.01 - 0.04	0.02 - 0.06	0.03 - 0.08	0.04 - 0.10
0.001 - 0.006	0.003 - 0.01	0.005 - 0.02	0.01 - 0.04	0.02 - 0.06	0.03 - 0.08	0.04 - 0.10
0.001 - 0.002	0.0015 - 0.004	0.002 - 0.008	0.003 - 0.012	0.008 - 0.02	0.03 - 0.04	0.015 - 0.05
0.001 - 0.005	0.003 - 0.012	0.005 - 0.025	0.01 - 0.04	0.02 - 0.06	0.03 - 0.08	0.04 - 0.10
0.002 - 0.01	0.004 - 0.02	0.006 - 0.04	0.015 - 0.08	0.03 - 0.10	0.04 - 0.15	0.05 - 0.20
0.002 - 0.008	0.003 - 0.015	0.005 - 0.03	0.01 - 0.06	0.02 - 0.08	0.03 - 0.10	0.04 - 0.15
0.002 - 0.005	0.003 - 0.012	0.005 - 0.025	0.01 - 0.08	0.03 - 0.10	0.04 - 0.15	0.05 - 0.20
0.002 - 0.015	0.004 - 0.025	0.006 - 0.05	0.015 - 0.06	0.02 - 0.08	0.03 - 0.12	0.04 - 0.15
0.002 - 0.02	0.005 - 0.03	0.008 - 0.06	0.02 - 0.10	0.04 - 0.12	0.05 - 0.20	0.06 - 0.25
0.002 - 0.01	0.003 - 0.02	0.006 - 0.05	0.015 - 0.06	0.02 - 0.08	0.03 - 0.10	0.04 - 0.15



CONDITIONS DE COUPE

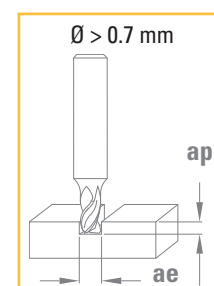
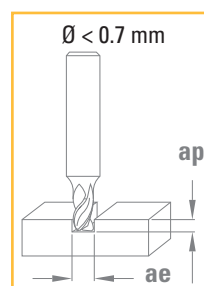

Matières à usiner			CARBURE		CUTINOX		$\varnothing < 0.7 \text{ mm}$		$\varnothing > 0.7 \text{ mm}$	
			Vc [m/min]	Vc [m/min]	Vc [m/min]	Vc [m/min]	ap [mm]	ae [mm]	ap [mm]	ae [mm]
P	Acier non allié / faiblement allié	< 600 N/mm ²	50	80	80	120	0.4 x ØD1	< 1 x ØD1	0.5 x ØD1	< 1 x ØD1
P	Acier non allié / faiblement allié	600 – 1500 N/mm ²	30	60	70	100	0.3 x ØD1	< 1 x ØD1	0.5 x ØD1	< 1 x ØD1
P	Acier de décolletage au plomb		80	120	100	180	0.5 x ØD1	< 1 x ØD1	0.5 x ØD1	< 1 x ØD1
P	Acier fortement allié	700 – 1500 N/mm ²	30	50	40	70	0.25 x ØD1	< 1 x ØD1	0.4 x ØD1	< 1 x ØD1
M	Acier inoxydable	400 – 700 N/mm ²	40	60	60	90	0.25 x ØD1	< 1 x ØD1	0.4 x ØD1	< 1 x ØD1
M	Acier inox. DUPLEX, acier austénitique inox. sans nickel	> 800 N/mm ²	20	40	30	60	0.2 x ØD1	< 1 x ØD1	0.35 x ØD1	< 1 x ØD1
K	Fonte grise / Fonte à graphite sphéroïdal perlitique	< 250 HB	100	150	150	200	0.5 x ØD1	< 1 x ØD1	0.5 x ØD1	< 1 x ØD1
K	Fonte allié / Fonte à graphite sphéroïdal perlitique	> 250 HB	50	80	60	100	0.4 x ØD1	< 1 x ØD1	0.5 x ØD1	< 1 x ØD1
K	Fonte à graphite sphéroïdal ferritique / Fonte malléable		50	80	60	90	0.4 x ØD1	< 1 x ØD1	0.5 x ØD1	< 1 x ØD1
S	Super alliages / Acier inox. réfractaire	Inconel Nimonic Hastelloy	10	20	20	40	0.1 x ØD1	< 1 x ØD1	0.2 x ØD1	< 1 x ØD1
S	Titane, alliage de titane		30	60	40	70	0.4 x ØD1	< 1 x ØD1	0.5 x ØD1	< 1 x ØD1
N	Alliage de cuivre / bonne usinabilité (laiton – bronze)		150	250	100	250	0.5 x ØD1	< 1 x ØD1	0.5 x ØD1	< 1 x ØD1
N	Alliage de cuivre / usinabilité difficile / Bronze à l'aluminium	(CuAlFe) (Ampco)	80	150	80	150	0.4 x ØD1	< 1 x ØD1	0.5 x ØD1	< 1 x ØD1
N	Alliage d'aluminium	Si < 8%	150	300	150	300	0.5 x ØD1	< 1 x ØD1	0.5 x ØD1	< 1 x ØD1
N	Fonte d'aluminium	Si > 8%	100	150	150	250	1.5 x ØD1	< 1 x ØD1	0.5 x ØD1	< 1 x ØD1
N	Plastique		100	150	100	150	1.5 x ØD1	< 1 x ØD1	0.5 x ØD1	< 1 x ØD1
N	Or, argent		100	150	100	150	0.5 x ØD1	< 1 x ØD1	0.5 x ØD1	< 1 x ØD1

Les valeurs n et Vf sont indicatives et devront être ajustées en fonction de la longueur L₂ de l'outil



$$n \text{ [tr/min]} = \frac{Vc \text{ [m/min]} \times 1000}{\pi \times D_1 \text{ [mm]}}$$

$$Vf \text{ [mm/min]} = n \text{ [tr/min]} \times fz \text{ [mm]} \times Z$$

Avance par dent **fz [mm]**

$\emptyset D_1$ 0.30 - 0.50	$\emptyset D_1$ 0.60 - 0.90	$\emptyset D_1$ 1.00 - 2.00	$\emptyset D_1$ 2.00 - 4.00	$\emptyset D_1$ 4.00 - 6.00	$\emptyset D_1$ 6.00 - 8.00	$\emptyset D_1$ 80.00 - 10.00
0.002 - 0.005	0.003 - 0.012	0.005 - 0.025	0.01 - 0.06	0.02 - 0.08	0.03 - 0.12	0.04 - 0.15
0.001 - 0.004	0.003 - 0.01	0.005 - 0.02	0.01 - 0.04	0.02 - 0.06	0.03 - 0.08	0.04 - 0.10
0.002 - 0.008	0.004 - 0.016	0.006 - 0.03	0.015 - 0.07	0.015 - 0.09	0.04 - 0.15	0.1 - 0.20
0.001 - 0.003	0.002 - 0.01	0.003 - 0.015	0.008 - 0.03	0.03 - 0.04	0.03 - 0.06	0.04 - 0.08
0.001 - 0.003	0.002 - 0.01	0.003 - 0.013	0.008 - 0.03	0.013 - 0.04	0.03 - 0.06	0.04 - 0.08
0.001 - 0.003	0.002 - 0.008	0.003 - 0.01	0.004 - 0.02	0.008 - 0.03	0.01 - 0.04	0.02 - 0.05
0.002 - 0.005	0.003 - 0.012	0.005 - 0.025	0.01 - 0.06	0.02 - 0.08	0.03 - 0.12	0.1 - 0.20
0.001 - 0.002	0.003 - 0.015	0.005 - 0.02	0.01 - 0.04	0.02 - 0.06	0.03 - 0.08	0.04 - 0.10
0.001 - 0.006	0.003 - 0.01	0.005 - 0.02	0.01 - 0.04	0.02 - 0.06	0.03 - 0.08	0.04 - 0.10
0.001 - 0.002	0.0015 - 0.004	0.002 - 0.008	0.003 - 0.012	0.008 - 0.02	0.03 - 0.04	0.015 - 0.05
0.001 - 0.005	0.003 - 0.012	0.005 - 0.025	0.01 - 0.04	0.02 - 0.06	0.03 - 0.08	0.04 - 0.10
0.002 - 0.01	0.004 - 0.02	0.006 - 0.04	0.015 - 0.08	0.03 - 0.10	0.04 - 0.15	0.05 - 0.20
0.002 - 0.008	0.003 - 0.015	0.005 - 0.03	0.01 - 0.06	0.02 - 0.08	0.03 - 0.10	0.04 - 0.15
0.002 - 0.005	0.003 - 0.012	0.005 - 0.025	0.01 - 0.08	0.03 - 0.10	0.04 - 0.15	0.05 - 0.20
0.002 - 0.015	0.004 - 0.025	0.006 - 0.05	0.015 - 0.06	0.02 - 0.08	0.03 - 0.12	0.04 - 0.15
0.002 - 0.02	0.005 - 0.03	0.008 - 0.06	0.02 - 0.10	0.04 - 0.12	0.05 - 0.20	0.06 - 0.25
0.002 - 0.01	0.003 - 0.02	0.006 - 0.05	0.015 - 0.06	0.02 - 0.08	0.03 - 0.10	0.04 - 0.15



CONDITIONS DE COUPE

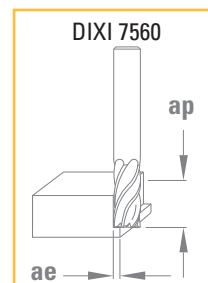

Matières à usiner

			CARBURE		TiAIN		DLC		ap [mm]	ae [mm]
			Vc [m/min]		Vc [m/min]		Vc [m/min]			
P	Acier non allié / faiblement allié	< 600 N/mm ²	90	110	110	130			1.50 x ØD1	< 0.10 x ØD1
P	Acier non allié / faiblement allié	600 – 1500 N/mm ²			80	100			1.50 x ØD1	< 0.10 x ØD1
P	Acier de décolletage au plomb		80	110					1.50 x ØD1	< 0.30 x ØD1
P	Acier fortement allié	700 – 1500 N/mm ²			60	80			1.50 x ØD1	< 0.05 x ØD1
M	Acier inoxydable	400 – 700 N/mm ²			80	100			1.50 x ØD1	< 0.05 x ØD1
M	Acier inox. DUPLEX, acier austénitique inox. sans nickel	> 800 N/mm ²			60	80			1.50 x ØD1	< 0.05 x ØD1
K	Fonte grise / Fonte à graphite sphéroïdal perlitique	< 250 HB	80	110	110	140			1.50 x ØD1	< 0.20 x ØD1
K	Fonte allié / Fonte à graphite sphéroïdal perlitique	> 250 HB	50	70	80	100			1.50 x ØD1	< 0.05 x ØD1
K	Fonte à graphite sphéroïdal ferritique / Fonte malléable		80	110	110	130			1.50 x ØD1	< 0.10 x ØD1
S	Super alliages / Acier inox. réfractaire	Inconel Nimonic Hastelloy			35	50			1.50 x ØD1	< 0.05 x ØD1
S	Titane, alliage de titane		40	55			50	80	1.50 x ØD1	< 0.10 x ØD1
N	Alliage de cuivre / bonne usinabilité (laiton – bronze)		160	200			200	300	1.50 x ØD1	< 0.30 x ØD1
N	Alliage de cuivre / usinabilité difficile / Bronze à l'aluminium (CuAlFe) (Ampco)		140	160	170	220	200	270	1.50 x ØD1	< 0.10 x ØD1

DIXI 7060 - 7063 - 7232

CONDITIONS DE COUPE

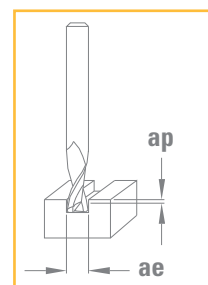

Matières à usiner

			CARBURE		ap [mm]	ae [mm]
			Vc [m/min]			
K	Fonte grise / Fonte à graphite sphéroïdal perlitique	< 250 HB	100	150	< 1 x ØD1	1 x ØD1
N	Alliage de cuivre / bonne usinabilité (laiton – bronze)		140	160	< 1 x ØD1	1 x ØD1
N	Plastique		140	160	< 0.9 x ØD1	1 x ØD1
N	Or, argent		240	260	< 1.2 x ØD1	1 x ØD1
N	Alliage d'aluminium	Si < 8%	240	300	< 1.2 x ØD1	1 x ØD1



$$n \text{ [tr/min]} = \frac{Vc \text{ [m/min]} \times 1000}{\pi \times D_1 \text{ [mm]}}$$

$$Vf \text{ [mm/min]} = n \text{ [tr/min]} \times fz \text{ [mm]} \times Z$$

Avance par dent **fz [mm]**

$\emptyset D_1$ 0.35 - 1.90 (Z = 3)	$\emptyset D_1$ 2.00 - 3.00 (Z = 5)	$\emptyset D_1$ 3.00 - 5.00 (Z = 5)	$\emptyset D_1$ 5.00 - 8.00 (Z = 5)	$\emptyset D_1$ 8.00 - 10.00 (Z = 6)	$\emptyset D_1$ 10.00 - 14.00 (Z = 6)	$\emptyset D_1$ 14.00 - 16.00 (Z = 6)	$\emptyset D_1$ 16.00 - 20.00 (Z = 6)
0.004 - 0.02	0.016 - 0.04	0.02 - 0.06	0.03 - 0.07	0.04 - 0.08	0.05 - 0.09	0.06 - 0.10	0.07 - 0.11
0.004 - 0.02	0.016 - 0.04	0.02 - 0.06	0.03 - 0.07	0.04 - 0.08	0.05 - 0.09	0.06 - 0.10	0.07 - 0.11
0.004 - 0.02	0.016 - 0.04	0.02 - 0.06	0.03 - 0.07	0.04 - 0.08	0.05 - 0.09	0.07 - 0.10	0.08 - 0.11
0.002 - 0.015	0.016 - 0.04	0.02 - 0.06	0.03 - 0.07	0.04 - 0.08	0.05 - 0.09	0.06 - 0.10	0.07 - 0.11
0.002 - 0.015	0.016 - 0.04	0.02 - 0.06	0.03 - 0.07	0.04 - 0.08	0.05 - 0.09	0.06 - 0.10	0.07 - 0.11
0.002 - 0.015	0.016 - 0.04	0.02 - 0.06	0.03 - 0.07	0.04 - 0.08	0.05 - 0.09	0.06 - 0.10	0.07 - 0.11
0.004 - 0.02	0.016 - 0.04	0.02 - 0.06	0.03 - 0.07	0.04 - 0.08	0.05 - 0.09	0.06 - 0.10	0.07 - 0.11
0.004 - 0.02	0.016 - 0.04	0.02 - 0.06	0.03 - 0.07	0.04 - 0.08	0.05 - 0.09	0.06 - 0.10	0.07 - 0.11
0.002 - 0.01	0.016 - 0.04	0.02 - 0.06	0.03 - 0.07	0.04 - 0.08	0.05 - 0.09	0.06 - 0.10	0.07 - 0.11
0.002 - 0.01	0.016 - 0.04	0.02 - 0.06	0.03 - 0.07	0.04 - 0.08	0.05 - 0.09	0.06 - 0.10	0.07 - 0.11
0.004 - 0.02	0.016 - 0.04	0.02 - 0.06	0.03 - 0.07	0.04 - 0.08	0.05 - 0.09	0.07 - 0.10	0.08 - 0.11
0.004 - 0.02	0.016 - 0.04	0.02 - 0.06	0.03 - 0.07	0.04 - 0.08	0.05 - 0.09	0.06 - 0.10	0.07 - 0.11

Avance par dent **fz [mm]**

$\emptyset D_1$ 0.40 - 1.00	$\emptyset D_1$ 1.00 - 1.50	$\emptyset D_1$ 1.50 - 3.00	$\emptyset D_1$ 3.00 - 5.00	$\emptyset D_1$ 5.00 - 7.00	$\emptyset D_1$ 7.00 - 10.00
0.006 - 0.015	0.012 - 0.020	0.016 - 0.04	0.02 - 0.06	0.03 - 0.09	0.04 - 0.11
0.006 - 0.015	0.012 - 0.020	0.016 - 0.04	0.02 - 0.06	0.03 - 0.09	0.04 - 0.11
0.006 - 0.015	0.012 - 0.020	0.016 - 0.04	0.02 - 0.06	0.03 - 0.09	0.04 - 0.11
0.006 - 0.015	0.012 - 0.020	0.016 - 0.04	0.02 - 0.06	0.03 - 0.09	0.04 - 0.11
0.006 - 0.015	0.012 - 0.020	0.016 - 0.04	0.02 - 0.06	0.03 - 0.09	0.04 - 0.11



CONDITIONS DE COUPE

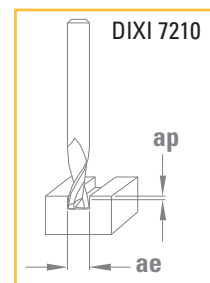
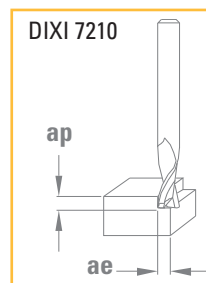

Matières à usiner

			CARBURE		CUTINOX		ap	ae	ap	ae
			Vc [m/min]	Vc [m/min]	[mm]	[mm]	[mm]	[mm]		
P	Acier non allié / faiblement allié	< 600 N/mm ²	70	100	100	120	1.5 x ØD1	0.5 x ØD1	< 1.3 x ØD1	1 x ØD1
P	Acier non allié / faiblement allié	600 – 1500 N/mm ²			80	100	1.5 x ØD1	0.5 x ØD1	< 1.0 x ØD1	1 x ØD1
P	Acier de décolletage au plomb		70	100			1.5 x ØD1	0.5 x ØD1	< 1.0 x ØD1	1 x ØD1
P	Acier fortement allié	700 – 1500 N/mm ²			50	70	1.5 x ØD1	0.5 x ØD1	< 1.0 x ØD1	1 x ØD1
M	Acier inoxydable	400 – 700 N/mm ²			80	100	1.5 x ØD1	0.5 x ØD1	< 1.0 x ØD1	1 x ØD1
K	Fonte grise / Fonte à graphite sphéroïdal perlitique	< 250 HB	70	100	100	120	1.5 x ØD1	0.5 x ØD1	< 1.0 x ØD1	1 x ØD1
K	Fonte alliée / Fonte à graphite sphéroïdal perlitique	> 250 HB	40	70	80	100	1.5 x ØD1	0.5 x ØD1	< 1.0 x ØD1	1 x ØD1
K	Fonte à graphite sphéroïdal ferritique / Fonte malléable		70	100	100	120	1.5 x ØD1	0.5 x ØD1	< 1.0 x ØD1	1 x ØD1
S	Titane, alliage de titane		30	45			1.5 x ØD1	0.5 x ØD1	< 1.0 x ØD1	1 x ØD1
N	Alliage de cuivre / bonne usinabilité (laiton – bronze)		160	180	220	240	1.0 x ØD1	1.0 x ØD1	< 1.5 x ØD1	0.5 x ØD1
N	Alliage de cuivre / usinabilité difficile / Bronze à l'aluminium (CuAlFe) (Ampco)		100	130	120	150	1.0 x ØD1	1.0 x ØD1	< 1.5 x ØD1	0.5 x ØD1
N	Alliage d'aluminium	Si < 8%	130	250	200	300	1.5 x ØD1	0.5 x ØD1	< 1.0 x ØD1	
N	Or, argent		140	160	200	220	< 1.0 x ØD1	1 x ØD1	< 1.5 x ØD1	< 0.5 x ØD1

DIXI 7301 - 7302 - 7303

CONDITIONS DE COUPE

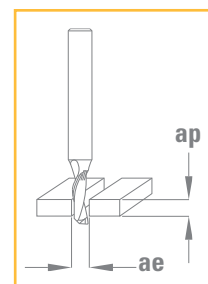

Matières à usiner

		CARBURE		ap	ae
		Vc [m/min]	Vc [m/min]	[mm]	[mm]
N	Plastique	130	200	< 1.5 x ØD1	1 x ØD1

L'avance en plongée (Vfp) d'une fraise Z = 1 (perçage) doit être réduite de 40 à 80 % en fonction de la matière à usiner.



$$n \text{ [tr/min]} = \frac{Vc \text{ [m/min]} \times 1000}{\pi \times D_1 \text{ [mm]}}$$

$$Vf \text{ [mm/min]} = n \text{ [tr/min]} \times fz \text{ [mm]} \times Z$$

Avance par dent **fz [mm]**

$\emptyset D_1$ 3.00 - 4.00	$\emptyset D_1$ 4.00 - 5.00	$\emptyset D_1$ 5.00 - 6.00	$\emptyset D_1$ 6.00 - 7.00	$\emptyset D_1$ 7.00 - 8.00	$\emptyset D_1$ 8.00 - 10.00	$\emptyset D_1$ 10.00 - 12.00	
0.02 - 0.03	0.025 - 0.04	0.028 - 0.045	0.032 - 0.05	0.035 - 0.06	0.04 - 0.08	0.06 - 0.10	
0.02 - 0.03	0.025 - 0.04	0.028 - 0.045	0.032 - 0.05	0.035 - 0.06	0.04 - 0.08	0.06 - 0.10	
0.02 - 0.03	0.025 - 0.04	0.028 - 0.045	0.032 - 0.05	0.035 - 0.06	0.04 - 0.08	0.06 - 0.10	
0.02 - 0.03	0.025 - 0.04	0.028 - 0.045	0.032 - 0.05	0.035 - 0.06	0.04 - 0.08	0.06 - 0.10	
0.02 - 0.03	0.025 - 0.04	0.028 - 0.045	0.032 - 0.05	0.035 - 0.06	0.04 - 0.08	0.06 - 0.10	
0.02 - 0.03	0.025 - 0.04	0.028 - 0.045	0.032 - 0.05	0.035 - 0.06	0.04 - 0.08	0.06 - 0.10	
0.02 - 0.03	0.025 - 0.04	0.028 - 0.045	0.032 - 0.05	0.035 - 0.06	0.04 - 0.08	0.06 - 0.10	
0.02 - 0.03	0.025 - 0.04	0.028 - 0.045	0.032 - 0.05	0.035 - 0.06	0.04 - 0.08	0.06 - 0.10	
0.02 - 0.03	0.025 - 0.04	0.028 - 0.045	0.032 - 0.05	0.035 - 0.06	0.04 - 0.08	0.06 - 0.10	
0.02 - 0.03	0.025 - 0.04	0.028 - 0.045	0.032 - 0.05	0.035 - 0.06	0.04 - 0.08	0.06 - 0.10	
0.02 - 0.03	0.025 - 0.04	0.028 - 0.045	0.032 - 0.05	0.035 - 0.06	0.04 - 0.08	0.06 - 0.10	
0.02 - 0.03	0.025 - 0.04	0.028 - 0.045	0.032 - 0.05	0.035 - 0.06	0.04 - 0.08	0.06 - 0.10	
0.03 - 0.04	0.04 - 0.06	0.05 - 0.08	0.06 - 0.09	0.07 - 0.1	0.08 - 0.11	0.09 - 0.12	
0.010 - 0.03	0.013 - 0.03	0.015 - 0.04	0.018 - 0.04	0.020 - 0.05	0.023 - 0.05	0.025 - 0.06	

Avance par dent **fz [mm]**

$\emptyset D_1$ 2.00 - 2.50	$\emptyset D_1$ 2.50 - 3.00	$\emptyset D_1$ 3.00 - 4.00	$\emptyset D_1$ 4.00 - 5.00	$\emptyset D_1$ 5.00 - 6.00	$\emptyset D_1$ 6.00 - 8.00	$\emptyset D_1$ 8.00 - 10.00	$\emptyset D_1$ 10.00 - 12.00	
0.020 - 0.05	0.025 - 0.06	0.03 - 0.08	0.04 - 0.10	0.05 - 0.12	0.06 - 0.16	0.08 - 0.20	0.10 - 0.28	



CONDITIONS DE COUPE

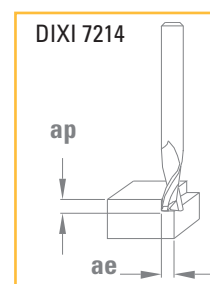
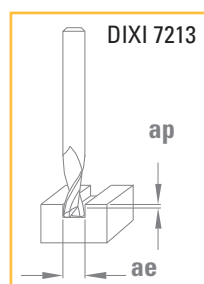

Matières à usiner

			CARBURE		TiAlN		ap [mm]	ae [mm]	ap [mm]	ae [mm]
			Vc [m/min]	Vc [m/min]	Vc [m/min]	Vc [m/min]				
P	Acier non allié / faiblement allié	< 600 N/mm ²	70	100	90	110	< 1.0 x ØD1	1 x ØD1	< 1 x ØD1	< 0.5 x ØD1
P	Acier non allié / faiblement allié	600 – 1500 N/mm ²			70	90	< 0.5 x ØD1	1 x ØD1	< 1 x ØD1	< 0.3 x ØD1
P	Acier de décolletage au plomb		70	100			< 1.0 x ØD1	1 x ØD1	< 1.5 x ØD1	< 0.5 x ØD1
P	Acier fortement allié	700 – 1500 N/mm ²			40	60	< 0.5 x ØD1	1 x ØD1	< 1 x ØD1	< 0.3 x ØD1
M	Acier inoxydable	400 – 700 N/mm ²			80	100	< 0.5 x ØD1	1 x ØD1	< 1 x ØD1	< 0.3 x ØD1
K	Fonte grise / Fonte à graphite sphéroïdal perlitique	< 250 HB	70	100	90	110	< 1.0 x ØD1	1 x ØD1	< 1 x ØD1	< 0.5 x ØD1
K	Fonte allié / Fonte à graphite sphéroïdal perlitique	> 250 HB	40	70	70	90	< 0.4 x ØD1	1 x ØD1	< 1 x ØD1	< 0.4 x ØD1
K	Fonte à graphite sphéroïdal ferritique / Fonte malléable		70	100	90	110	< 0.4 x ØD1	1 x ØD1	< 1 x ØD1	< 0.4 x ØD1
S	Titane, alliage de titane		30	45			< 0.5 x ØD1	1 x ØD1	< 1 x ØD1	< 0.3 x ØD1
N	Alliage de cuivre / bonne usinabilité (laiton – bronze)		140	160			< 2.0 x ØD1	1 x ØD1	< 1.5 x ØD1	< 0.5 x ØD1
N	Alliage de cuivre / usinabilité difficile / Bronze à l'aluminium (CuAlFe) (Ampco)		120	140	170	190	< 1.0 x ØD1	1 x ØD1	< 1 x ØD1	< 0.3 x ØD1
N	Alliage d'aluminium	Si < 8%	180	260	230	340	< 2.0 x ØD1	1 x ØD1	< 1.5 x ØD1	< 0.5 x ØD1
N	Fonte d'aluminium	Si > 8%	140	160	210	230	< 2.0 x ØD1	1 x ØD1	< 1.5 x ØD1	< 0.5 x ØD1
N	Or, argent		140	160	200	220	< 1.0 x ØD1	1 x ØD1	< 1.5 x ØD1	< 0.5 x ØD1



$$n \text{ [tr/min]} = \frac{Vc \text{ [m/min]} \times 1000}{\pi \times D_1 \text{ [mm]}}$$

$$Vf \text{ [mm/min]} = n \text{ [tr/min]} \times fz \text{ [mm]} \times Z$$

Avance par dent **fz [mm]**

∅ D ₁ 4.00 - 5.00	∅ D ₁ 5.00 - 6.00	∅ D ₁ 6.00 - 7.00	∅ D ₁ 7.00 - 8.00	∅ D ₁ 8.00 - 9.00	∅ D ₁ 9.00 - 10.00	∅ D ₁ 10.00 - 12.00	∅ D ₁ 12.00 - 14.00	∅ D ₁ 14.00 - 16.00	∅ D ₁ 16.00 - 20.00
0.008 - 0.02	0.010 - 0.02	0.012 - 0.02	0.014 - 0.03	0.016 - 0.03	0.018 - 0.04	0.020 - 0.04	0.02 - 0.05	0.03 - 0.06	0.03 - 0.07
0.006 - 0.01	0.008 - 0.02	0.009 - 0.02	0.011 - 0.02	0.012 - 0.02	0.014 - 0.03	0.015 - 0.03	0.02 - 0.04	0.02 - 0.04	0.02 - 0.05
0.010 - 0.03	0.013 - 0.03	0.015 - 0.04	0.018 - 0.04	0.020 - 0.05	0.023 - 0.05	0.025 - 0.06	0.03 - 0.07	0.04 - 0.08	0.04 - 0.10
0.006 - 0.01	0.008 - 0.02	0.009 - 0.02	0.011 - 0.02	0.012 - 0.02	0.014 - 0.03	0.015 - 0.03	0.02 - 0.04	0.02 - 0.04	0.02 - 0.05
0.006 - 0.01	0.008 - 0.02	0.009 - 0.02	0.011 - 0.02	0.012 - 0.02	0.014 - 0.03	0.015 - 0.03	0.02 - 0.04	0.02 - 0.04	0.02 - 0.05
0.008 - 0.02	0.010 - 0.02	0.012 - 0.02	0.014 - 0.03	0.016 - 0.03	0.018 - 0.04	0.020 - 0.04	0.02 - 0.05	0.03 - 0.06	0.03 - 0.07
0.006 - 0.01	0.008 - 0.02	0.009 - 0.02	0.011 - 0.02	0.012 - 0.02	0.014 - 0.03	0.015 - 0.03	0.02 - 0.04	0.02 - 0.04	0.02 - 0.05
0.008 - 0.02	0.010 - 0.02	0.012 - 0.02	0.014 - 0.03	0.016 - 0.03	0.018 - 0.04	0.020 - 0.04	0.02 - 0.05	0.03 - 0.06	0.03 - 0.07
0.006 - 0.01	0.008 - 0.02	0.009 - 0.02	0.011 - 0.02	0.012 - 0.02	0.014 - 0.03	0.015 - 0.03	0.02 - 0.04	0.02 - 0.04	0.02 - 0.05
0.010 - 0.03	0.013 - 0.03	0.015 - 0.04	0.018 - 0.04	0.020 - 0.05	0.023 - 0.05	0.025 - 0.06	0.03 - 0.07	0.04 - 0.08	0.04 - 0.10
0.006 - 0.01	0.008 - 0.02	0.009 - 0.02	0.011 - 0.02	0.012 - 0.02	0.014 - 0.03	0.015 - 0.03	0.02 - 0.04	0.02 - 0.04	0.02 - 0.05
0.010 - 0.03	0.013 - 0.03	0.015 - 0.04	0.018 - 0.04	0.020 - 0.05	0.023 - 0.05	0.025 - 0.06	0.03 - 0.07	0.04 - 0.08	0.04 - 0.10
0.010 - 0.03	0.013 - 0.03	0.015 - 0.04	0.018 - 0.04	0.020 - 0.05	0.023 - 0.05	0.025 - 0.06	0.03 - 0.07	0.04 - 0.08	0.04 - 0.10
0.010 - 0.03	0.013 - 0.03	0.015 - 0.04	0.018 - 0.04	0.020 - 0.05	0.023 - 0.05	0.025 - 0.06	0.03 - 0.07	0.04 - 0.08	0.04 - 0.10



CONDITIONS DE COUPE

Tréflage

Matières à usiner	XIDUR Vc [m/min]	ap [mm]
P Acier non allié / faiblement allié < 600 N/mm ²	175	<1xØD ₁
P Acier non allié / faiblement allié 600 – 1500 N/mm ²	140	<1xØD ₁
P Acier de décolletage au plomb	175	<1xØD ₁
P Acier fortement allié 700 – 1500 N/mm ²	140	<1xØD ₁
H Acier à outils >50HRC	50	<0.8xØD ₁
M Acier inoxydable 400 – 700 N/mm ²	80	<0.8xØD ₁
M Acier inox. DUPLEX, acier austénitique inox. sans nickel > 800 N/mm ²	60	<1xØD ₁
K Fonte grise / Fonte à graphite sphéroïdal perlitique < 250 HB	110	<1xØD ₁
K Fonte alliée / Fonte à graphite sphéroïdal perlitique > 250 HB	70	<1xØD ₁
K Fonte à graphite sphéroïdal ferritique / Fonte malléable	80	<1xØD ₁
S Super alliages / Acier inox. réfractaire	80	<0.8xØD ₁
S Titane, alliage de titane	70	<0.8xØD ₁

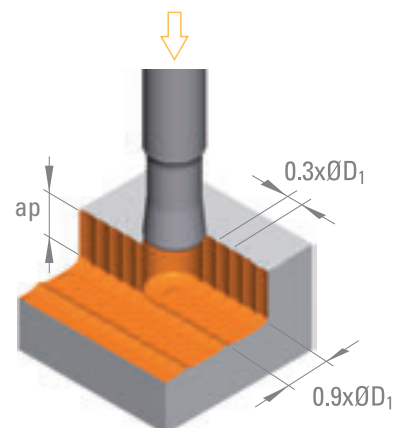

Descente en rampe

Matières à usiner	XIDUR Vc [m/min]	α [°]
P Acier non allié / faiblement allié < 600 N/mm ²	200	<1xØD ₁
P Acier non allié / faiblement allié 600 – 1500 N/mm ²	150	0.75
P Acier de décolletage au plomb	200	0.75
P Acier fortement allié 700 – 1500 N/mm ²	150	0.75
H Acier à outils >50HRC	200	0.75
M Acier inoxydable 400 – 700 N/mm ²	110	0.50
M Acier inox. DUPLEX, acier austénitique inox. sans nickel > 800 N/mm ²	80	0.50
K Fonte grise / Fonte à graphite sphéroïdal perlitique < 250 HB	150	0.75
K Fonte alliée / Fonte à graphite sphéroïdal perlitique > 250 HB	100	0.75
K Fonte à graphite sphéroïdal ferritique / Fonte malléable	80	0.75
S Super alliages / Acier inox. réfractaire	60	0.50
S Titane, alliage de titane	80	0.50

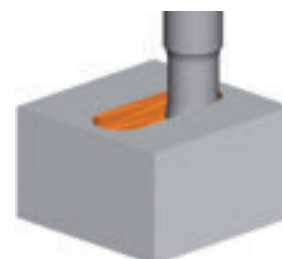
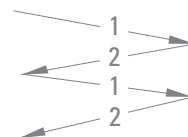

Calcul des valeurs de la rampe:

1. $h = \ell \times \tan \alpha$
 2. Retour à l'horizontal ℓ

Interpolation hélicoïdale

Matières à usiner	XIDUR Vc [m/min]	α [°]
P Acier non allié / faiblement allié < 600 N/mm ²	250	0.75
P Acier non allié / faiblement allié 600 – 1500 N/mm ²	200	0.75
P Acier de décolletage au plomb	250	0.75
P Acier fortement allié 700 – 1500 N/mm ²	200	0.75
H Acier à outils >50HRC	200	0.75
M Acier inoxydable 400 – 700 N/mm ²	150	0.50
M Acier inox. DUPLEX, acier austénitique inox. sans nickel > 800 N/mm ²	110	0.50
K Fonte grise / Fonte à graphite sphéroïdal perlitique < 250 HB	150	0.75
K Fonte alliée / Fonte à graphite sphéroïdal perlitique > 250 HB	100	0.75
K Fonte à graphite sphéroïdal ferritique / Fonte malléable	80	0.75
S Super alliages / Acier inox. réfractaire	80	0.50
S Titane, alliage de titane	100	0.50

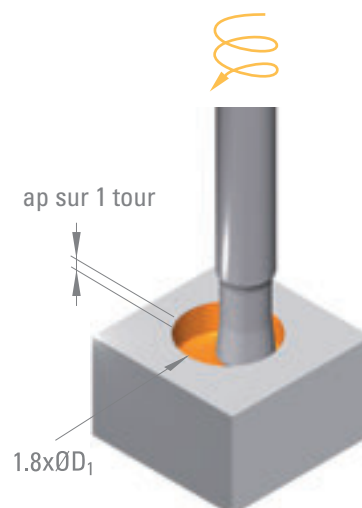

Calcul des valeurs d'hélice:
 $ap \text{ sur 1 tour} = \pi \times D_1 \times \tan \alpha$



Avance par dent **fz [mm]**

Ø D ₁	Ø D ₁	Ø D ₁	Ø D ₁	Ø D ₁	Ø D ₁	Ø D ₁	Ø D ₁	Ø D ₁	Ø D ₁	Ø D ₁	Ø D ₁
0.50	0.80	1.00	1.50	2.00	3.00	4.00	5.00	6.00	8.00	10.00	12.00
0.004	0.006	0.008	0.012	0.016	0.024	0.032	0.040	0.048	0.064	0.080	0.096
0.003	0.005	0.006	0.010	0.013	0.019	0.026	0.032	0.038	0.051	0.064	0.077
0.004	0.006	0.008	0.012	0.016	0.024	0.032	0.040	0.048	0.064	0.080	0.096
0.003	0.005	0.006	0.010	0.013	0.019	0.026	0.032	0.038	0.051	0.064	0.077
0.003	0.004	0.006	0.008	0.011	0.017	0.022	0.028	0.034	0.045	0.056	0.067
0.003	0.004	0.006	0.008	0.011	0.017	0.022	0.028	0.034	0.045	0.056	0.067
0.003	0.004	0.006	0.008	0.011	0.017	0.022	0.028	0.034	0.045	0.056	0.067
0.004	0.006	0.008	0.012	0.016	0.024	0.032	0.040	0.048	0.064	0.080	0.096
0.003	0.005	0.006	0.010	0.013	0.019	0.026	0.032	0.038	0.051	0.064	0.077
0.003	0.004	0.006	0.008	0.011	0.017	0.022	0.028	0.034	0.045	0.056	0.067
0.002	0.004	0.005	0.007	0.010	0.014	0.019	0.024	0.029	0.038	0.048	0.058
0.003	0.004	0.006	0.008	0.011	0.017	0.022	0.028	0.034	0.045	0.056	0.067

Avance par dent **fz [mm]**

Ø D ₁	Ø D ₁	Ø D ₁	Ø D ₁	Ø D ₁	Ø D ₁	Ø D ₁	Ø D ₁	Ø D ₁	Ø D ₁	Ø D ₁	Ø D ₁
0.50	0.80	1.00	1.50	2.00	3.00	4.00	5.00	6.00	8.00	10.00	12.00
0.013	0.021	0.026	0.040	0.053	0.079	0.106	0.132	0.158	0.211	0.264	0.317
0.012	0.019	0.024	0.036	0.048	0.072	0.096	0.120	0.144	0.192	0.240	0.288
0.013	0.021	0.026	0.040	0.053	0.079	0.106	0.132	0.158	0.211	0.264	0.317
0.012	0.019	0.024	0.036	0.048	0.072	0.096	0.120	0.144	0.192	0.240	0.288
0.004	0.006	0.008	0.012	0.016	0.024	0.032	0.040	0.048	0.064	0.080	0.096
0.010	0.015	0.019	0.029	0.038	0.058	0.077	0.096	0.115	0.154	0.192	0.230
0.010	0.015	0.019	0.029	0.038	0.058	0.077	0.096	0.115	0.154	0.192	0.230
0.010	0.015	0.019	0.029	0.038	0.058	0.077	0.096	0.115	0.154	0.192	0.230
0.007	0.012	0.014	0.022	0.029	0.043	0.058	0.072	0.086	0.115	0.144	0.173
0.006	0.010	0.013	0.019	0.026	0.038	0.051	0.064	0.077	0.102	0.128	0.154
0.007	0.012	0.014	0.022	0.029	0.043	0.058	0.072	0.086	0.115	0.144	0.173
0.008	0.013	0.017	0.025	0.034	0.050	0.067	0.084	0.101	0.134	0.168	0.202

Avance par dent **fz [mm]**

Ø D ₁	Ø D ₁	Ø D ₁	Ø D ₁	Ø D ₁	Ø D ₁	Ø D ₁	Ø D ₁	Ø D ₁	Ø D ₁	Ø D ₁	Ø D ₁
0.50	0.80	1.00	1.50	2.00	3.00	4.00	5.00	6.00	8.00	10.00	12.00
0.018	0.028	0.035	0.053	0.070	0.106	0.141	0.176	0.211	0.282	0.352	0.422
0.016	0.026	0.032	0.048	0.064	0.096	0.128	0.160	0.192	0.256	0.320	0.384
0.018	0.028	0.035	0.053	0.070	0.106	0.141	0.176	0.211	0.282	0.352	0.422
0.016	0.026	0.032	0.048	0.064	0.096	0.128	0.160	0.192	0.256	0.320	0.384
0.005	0.008	0.010	0.014	0.019	0.029	0.038	0.048	0.058	0.077	0.096	0.115
0.013	0.020	0.026	0.038	0.051	0.077	0.102	0.128	0.154	0.205	0.256	0.307
0.013	0.020	0.026	0.038	0.051	0.077	0.102	0.128	0.154	0.205	0.256	0.307
0.013	0.020	0.026	0.038	0.051	0.077	0.102	0.128	0.154	0.205	0.256	0.307
0.010	0.015	0.019	0.029	0.038	0.058	0.077	0.096	0.115	0.154	0.192	0.230
0.010	0.015	0.019	0.029	0.038	0.058	0.077	0.096	0.115	0.154	0.192	0.230
0.008	0.012	0.015	0.023	0.030	0.046	0.061	0.076	0.091	0.122	0.152	0.182
0.011	0.018	0.022	0.034	0.045	0.067	0.090	0.112	0.134	0.179	0.224	0.269



CONDITIONS DE COUPE

Contournage

Matières à usiner		XIDUR Vc [m/min]	ap [mm]
P	Acier non allié / faiblement allié < 600 N/mm ²	250	<0.5xØD ₁
P	Acier non allié / faiblement allié 600 – 1500 N/mm ²	200	<0.5xØD ₁
P	Acier de décolletage au plomb	250	<0.5xØD ₁
P	Acier fortement allié 700 – 1500 N/mm ²	200	<0.5xØD ₁
H	Acier à outils >50HRC	200	<0.4xØD ₁
M	Acier inoxydable 400 – 700 N/mm ²	150	<0.4xØD ₁
M	Acier inox. DUPLEX, acier austénitique inox. sans nickel > 800 N/mm ²	110	<0.4xØD ₁
K	Fonte grise / Fonte à graphite sphéroïdal perlitique < 250 HB	150	<0.5xØD ₁
K	Fonte alliée / Fonte à graphite sphéroïdal perlitique > 250 HB	100	<0.5xØD ₁
K	Fonte à graphite sphéroïdal ferritique / Fonte malléable	80	<0.5xØD ₁
S	Super alliages / Acier inox. réfractaire	80	<0.4xØD ₁
S	Titane, alliage de titane	100	<0.4xØD ₁

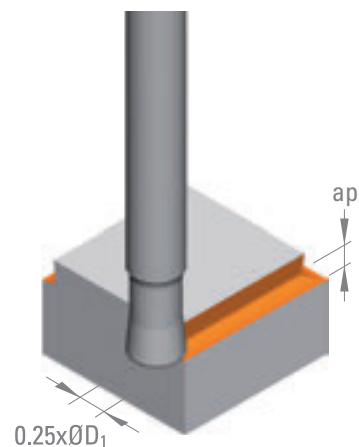

Surfaçage

Matières à usiner		XIDUR Vc [m/min]	ap [mm]
P	Acier non allié / faiblement allié < 600 N/mm ²	250	<1x ε
P	Acier non allié / faiblement allié 600 – 1500 N/mm ²	200	<1x ε
P	Acier de décolletage au plomb	250	<1x ε
P	Acier fortement allié 700 – 1500 N/mm ²	200	<1x ε
H	Acier à outils >50HRC	200	<0.8x ε
M	Acier inoxydable 400 – 700 N/mm ²	150	<0.8x ε
M	Acier inox. DUPLEX, acier austénitique inox. sans nickel > 800 N/mm ²	110	<0.8x ε
K	Fonte grise / Fonte à graphite sphéroïdal perlitique < 250 HB	150	<1x ε
K	Fonte alliée / Fonte à graphite sphéroïdal perlitique > 250 HB	100	<1x ε
K	Fonte à graphite sphéroïdal ferritique / Fonte malléable	80	<1x ε
S	Super alliages / Acier inox. réfractaire	80	<0.5x ε
S	Titane, alliage de titane	100	<0.5x ε

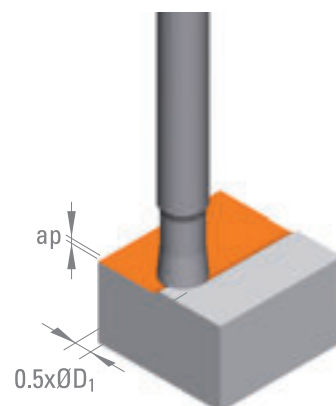

Cet outil ne possède pas de coupe au centre.

La valeur ε, en fonction du diamètre de l'outil, est un maximum.

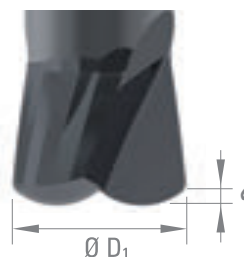

Avance par dent **fz [mm]**

Ø D ₁	Ø D ₁	Ø D ₁	Ø D ₁	Ø D ₁	Ø D ₁	Ø D ₁	Ø D ₁	Ø D ₁	Ø D ₁	Ø D ₁	Ø D ₁
0.50	0.80	1.00	1.50	2.00	3.00	4.00	5.00	6.00	8.00	10.00	12.00
0.010	0.017	0.021	0.031	0.042	0.062	0.083	0.104	0.125	0.166	0.208	0.250
0.010	0.015	0.019	0.029	0.038	0.058	0.077	0.096	0.115	0.154	0.192	0.230
0.010	0.017	0.021	0.031	0.042	0.062	0.083	0.104	0.125	0.166	0.208	0.250
0.010	0.015	0.019	0.029	0.038	0.058	0.077	0.096	0.115	0.154	0.192	0.230
0.005	0.008	0.010	0.014	0.019	0.029	0.038	0.048	0.058	0.077	0.096	0.115
0.008	0.013	0.016	0.024	0.032	0.048	0.064	0.080	0.096	0.128	0.160	0.192
0.008	0.013	0.016	0.024	0.032	0.048	0.064	0.080	0.096	0.128	0.160	0.192
0.008	0.013	0.016	0.024	0.032	0.048	0.064	0.080	0.096	0.128	0.160	0.192
0.006	0.009	0.011	0.017	0.022	0.034	0.045	0.056	0.067	0.090	0.112	0.134
0.005	0.008	0.010	0.016	0.021	0.031	0.042	0.052	0.062	0.083	0.104	0.125
0.006	0.009	0.011	0.017	0.022	0.034	0.045	0.056	0.067	0.090	0.112	0.134
0.007	0.011	0.014	0.020	0.027	0.041	0.054	0.068	0.082	0.109	0.136	0.163

Avance par dent **fz [mm]**

Ø D ₁	Ø D ₁	Ø D ₁	Ø D ₁	Ø D ₁	Ø D ₁	Ø D ₁	Ø D ₁	Ø D ₁	Ø D ₁	Ø D ₁	Ø D ₁
0.50	0.80	1.00	1.50	2.00	3.00	4.00	5.00	6.00	8.00	10.00	12.00
0.022	0.035	0.044	0.066	0.088	0.132	0.176	0.220	0.264	0.352	0.440	0.528
0.020	0.032	0.040	0.060	0.080	0.120	0.160	0.200	0.240	0.320	0.400	0.480
0.022	0.035	0.044	0.066	0.088	0.132	0.176	0.220	0.264	0.352	0.440	0.528
0.020	0.032	0.040	0.060	0.080	0.120	0.160	0.200	0.240	0.320	0.400	0.480
0.006	0.010	0.012	0.018	0.024	0.036	0.048	0.060	0.072	0.096	0.120	0.144
0.016	0.026	0.032	0.048	0.064	0.096	0.128	0.160	0.192	0.256	0.320	0.384
0.016	0.026	0.032	0.048	0.064	0.096	0.128	0.160	0.192	0.256	0.320	0.384
0.016	0.026	0.032	0.048	0.064	0.096	0.128	0.160	0.192	0.256	0.320	0.384
0.012	0.019	0.024	0.036	0.048	0.072	0.096	0.120	0.144	0.192	0.240	0.288
0.012	0.019	0.024	0.036	0.048	0.072	0.096	0.120	0.144	0.192	0.240	0.288
0.010	0.015	0.019	0.029	0.038	0.058	0.077	0.096	0.115	0.154	0.192	0.230
0.014	0.022	0.028	0.042	0.056	0.084	0.112	0.140	0.168	0.224	0.280	0.336
0.025	0.04	0.05	0.10	0.15	0.20	0.25	0.30	0.35	0.40	0.45	0.50

Valeur ζ

Téléchargez les conditions de coupe (pdf + xls) et les profils dxf



CONDITIONS DE COUPE

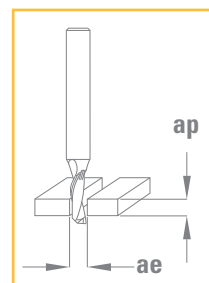

Matières à usiner

		CARBURE Vc [m/min]		ap [mm]	ae [mm]
P	Acier de décolletage au plomb	80	100	< 0.7 x ØD1	1 x ØD1
N	Alliage de cuivre / bonne usinabilité (laiton – bronze)	100	130	< 1 x ØD1	1 x ØD1
N	Alliage d'aluminium Si < 8%	120	160	< 1 x ØD1	1 x ØD1
N	Fonte d'aluminium Si > 8%	100	130	< 1 x ØD1	1 x ØD1
N	Plastique	130	200	< 1.5 x ØD1	1 x ØD1

L'avance en plongée (Vfp) d'une fraise Z = 1 (perçage) doit être réduite de 40 à 80 % en fonction de la matière à usiner.

DIXI 7552 - 7562 - 7572 - 7582

CONDITIONS DE COUPE

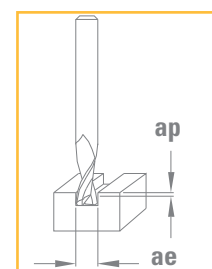

Matières à usiner

		CARBURE		TiAlN	DICUT	DIAMANT	ap [mm]	ae [mm]
		Vc [m/min]	Vc [m/min]	Vc [m/min]	Vc [m/min]	Vc [m/min]		
P	Acier non allié / faiblement allié < 600 N/mm ²	50	80				< 1 x ØD1	< 1 x ØD1
P	Acier non allié / faiblement allié 600 – 1500 N/mm ²			70	100		< 0.5 x ØD1	< 1 x ØD1
P	Acier fortement allié 700 – 1500 N/mm ²			40	60		< 0.5 x ØD1	< 1 x ØD1
K	Fonte grise / Fonte à graphite sphéroïdal perlitique < 250 HB	100	170				< 1 x ØD1	< 1 x ØD1
S	Titane, alliage de titane	60	80				< 1 x ØD1	< 1 x ØD1
N	Alliage de cuivre / bonne usinabilité (laiton – bronze)	80	120				< 1.5 x ØD1	< 1 x ØD1
N	Alliage de cuivre / usinabilité difficile / Bronze à l'aluminium (CuAlFe) (Ampco)			100	140		< 1 x ØD1	< 1 x ØD1
N	Alliage d'aluminium Si < 8%	150	200				< 1.5 x ØD1	< 1 x ØD1
N	Fonte d'aluminium Si > 8%	100	200				< 1 x ØD1	< 1 x ØD1
N	Graphite					200 300	3 x ØD1	< 0.30 x ØD1
N	Plastique	100	130				< 2 x ØD1	< 1 x ØD1
N	Or, argent	90	130	100	140		< 0.5 x ØD1	< 1 x ØD1



$$n \text{ [tr/min]} = \frac{V_c \text{ [m/min]} \times 1000}{\pi \times D_1 \text{ [mm]}}$$

$$V_f \text{ [mm/min]} = n \text{ [tr/min]} \times f_z \text{ [mm]} \times Z$$

Avance par dent **fz [mm]**

∅ D ₁ 2.00 - 2.50	∅ D ₁ 2.50 - 3.00	∅ D ₁ 3.00 - 4.00	∅ D ₁ 4.00 - 5.00	∅ D ₁ 5.00 - 6.00	∅ D ₁ 6.00 - 8.00	∅ D ₁ 8.00 - 10.00	∅ D ₁ 10.00 - 12.00
0.010 - 0.03	0.013 - 0.04	0.02 - 0.05	0.02 - 0.06	0.03 - 0.07	0.03 - 0.10	0.04 - 0.12	0.05 - 0.17
0.014 - 0.04	0.018 - 0.05	0.02 - 0.06	0.03 - 0.08	0.04 - 0.09	0.04 - 0.12	0.06 - 0.15	0.07 - 0.21
0.014 - 0.04	0.018 - 0.05	0.02 - 0.06	0.03 - 0.08	0.04 - 0.09	0.04 - 0.12	0.06 - 0.15	0.07 - 0.21
0.014 - 0.04	0.018 - 0.05	0.02 - 0.06	0.03 - 0.08	0.04 - 0.09	0.04 - 0.12	0.06 - 0.15	0.07 - 0.21
0.020 - 0.05	0.025 - 0.06	0.03 - 0.08	0.04 - 0.10	0.05 - 0.12	0.06 - 0.16	0.08 - 0.20	0.10 - 0.28

Avance par dent **fz [mm]**

∅ D ₁ 1.00 - 2.00	∅ D ₁ 2.00 - 3.00	∅ D ₁ 3.00 - 5.00	∅ D ₁ 5.00 - 7.00	∅ D ₁ 7.00 - 10.00	∅ D ₁ 10.00 - 13.00	∅ D ₁ 13.00 - 16.00	∅ D ₁ 16.00 - 20.00
0.012 - 0.02	0.018 - 0.04	0.03 - 0.06	0.04 - 0.09	0.07 - 0.12	0.06 - 0.14	0.07 - 0.16	0.08 - 0.20
0.012 - 0.02	0.018 - 0.04	0.03 - 0.06	0.04 - 0.09	0.07 - 0.12	0.06 - 0.14	0.07 - 0.16	0.08 - 0.20
0.012 - 0.02	0.018 - 0.04	0.03 - 0.06	0.04 - 0.09	0.07 - 0.12	0.06 - 0.14	0.07 - 0.16	0.08 - 0.20
0.012 - 0.02	0.018 - 0.04	0.03 - 0.06	0.04 - 0.09	0.07 - 0.12	0.06 - 0.14	0.07 - 0.16	0.08 - 0.20
0.012 - 0.02	0.018 - 0.04	0.03 - 0.06	0.04 - 0.09	0.07 - 0.12	0.06 - 0.14	0.07 - 0.16	0.08 - 0.20
0.012 - 0.02	0.018 - 0.04	0.03 - 0.06	0.04 - 0.09	0.07 - 0.12	0.06 - 0.14	0.07 - 0.16	0.08 - 0.20
0.012 - 0.02	0.018 - 0.04	0.03 - 0.06	0.04 - 0.09	0.07 - 0.12	0.06 - 0.14	0.07 - 0.16	0.08 - 0.20
0.012 - 0.02	0.018 - 0.04	0.03 - 0.06	0.04 - 0.09	0.07 - 0.12	0.06 - 0.14	0.07 - 0.16	0.08 - 0.20
0.014 - 0.04	0.018 - 0.05	0.021 - 0.05	0.025 - 0.06	0.032 - 0.08	0.04 - 0.09	0.04 - 0.11	0.05 - 0.12
0.012 - 0.02	0.018 - 0.04	0.03 - 0.06	0.04 - 0.09	0.07 - 0.12	0.06 - 0.14	0.07 - 0.16	0.08 - 0.20
0.012 - 0.02	0.018 - 0.04	0.03 - 0.06	0.04 - 0.09	0.07 - 0.12	0.06 - 0.14	0.07 - 0.16	0.08 - 0.20



DIXI 7543

CONDITIONS DE COUPE

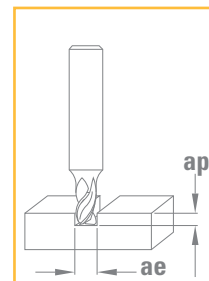

Matières à usiner

			XIDUR		ap [mm]	ae [mm]
			Vc [m/min]			
P	Acier non allié / faiblement allié	< 600 N/mm ²	90	110	< 1.0 x ØD1	1 x ØD1
P	Acier non allié / faiblement allié	600 – 1500 N/mm ²	70	90	< 0.6 x ØD1	1 x ØD1
P	Acier de décolletage au plomb		90	110	< 1.0 x ØD1	1 x ØD1
P	Acier fortement allié	700 – 1500 N/mm ²	40	55	< 0.3 x ØD1	1 x ØD1
M	Acier inoxydable	400 – 700 N/mm ²	70	90	< 0.8 x ØD1	1 x ØD1
K	Fonte grise / Fonte à graphite sphéroïdal perlitique	< 250 HB	90	110	< 0.7 x ØD1	1 x ØD1
K	Fonte alliée / Fonte à graphite sphéroïdal perlitique	> 250 HB	70	90	< 0.4 x ØD1	1 x ØD1
K	Fonte à graphite sphéroïdal ferritique / Fonte malléable		90	110	< 0.4 x ØD1	1 x ØD1
S	Titane, alliage de titane		40	60	< 0.3 x ØD1	1 x ØD1

DIXI 7593

CONDITIONS DE COUPE

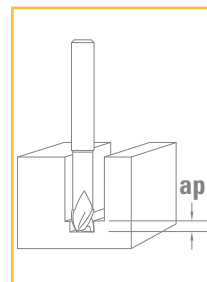

DIXI 7593 Z = 3-4

Aluminium

(Vc 400 - 600 m/min)

D ₁	Z	Vc [m/min]	n [min ⁻¹]	Vf [mm/min]	ap [mm]	ae [mm]	fz [mm]
6	3	400	21220	570	3	6	0.009
8	3	400	15920	570	4	8	0.012
10	3	400	12730	760	5	10	0.02
12	3	400	10610	760	6	12	0.024
16	3	400	7960	760	8	16	0.032
18	3	400	7070	760	9	18	0.036
20	4	400	6370	1020	10	20	0.04

$$n \text{ [tr/min]} = \frac{V_c \text{ [m/min]} \times 1000}{\pi \times D_1 \text{ [mm]}}$$

$$V_f \text{ [mm/min]} = n \text{ [tr/min]} \times f_z \text{ [mm]} \times Z$$

Avance par dent **fz [mm]**

$\emptyset D_1$ 1.00 - 1.50	$\emptyset D_1$ 1.50 - 3.00	$\emptyset D_1$ 3.00 - 5.00	$\emptyset D_1$ 5.00 - 7.00	$\emptyset D_1$ 7.00 - 10.00	$\emptyset D_1$ 10.00 - 12.00
0.002 - 0.01	0.003 - 0.01	0.006 - 0.02	0.010 - 0.02	0.014 - 0.04	0.02 - 0.05
0.002 - 0.01	0.002 - 0.01	0.005 - 0.01	0.008 - 0.02	0.011 - 0.03	0.02 - 0.04
0.003 - 0.01	0.004 - 0.01	0.008 - 0.03	0.013 - 0.04	0.018 - 0.05	0.03 - 0.07
0.002 - 0.01	0.002 - 0.01	0.005 - 0.01	0.008 - 0.02	0.011 - 0.03	0.02 - 0.04
0.002 - 0.01	0.002 - 0.01	0.005 - 0.01	0.008 - 0.02	0.011 - 0.03	0.02 - 0.04
0.002 - 0.01	0.003 - 0.01	0.006 - 0.02	0.010 - 0.02	0.014 - 0.04	0.02 - 0.05
0.002 - 0.01	0.002 - 0.01	0.005 - 0.01	0.008 - 0.02	0.011 - 0.03	0.02 - 0.04
0.002 - 0.01	0.003 - 0.01	0.006 - 0.02	0.010 - 0.02	0.014 - 0.04	0.02 - 0.05
0.002 - 0.01	0.002 - 0.01	0.005 - 0.01	0.008 - 0.02	0.011 - 0.03	0.02 - 0.04



CONDITIONS DE COUPE

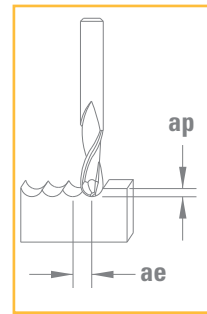

DIXI 7532 XIDUR Z = 2				Aciers à outils et fontes trempées		30-45 HRC (Vc 400 - 500 m/min)	
D	Vc [m/min]	n [min -1]	Vf [mm/min]	ap [mm]	ae [mm]	Deff. [mm]	fz [mm]
0.2 - 1		90000	1800	0.02	0.05	0.28	0.01
1.5	400	84890	3400	0.04	0.06	0.48	0.02
2	400	63660	3820	0.05	0.09	0.62	0.03
3	400	42440	3400	0.07	0.13	1.08	0.04
4	400	31830	3180	0.09	0.15	1.20	0.05
5	400	25470	3570	0.15	0.25	1.71	0.07
6	400	21220	3400	0.20	0.30	2.15	0.08
8	400	15920	3180	0.25	0.35	2.78	0.10
10	400	12730	3820	0.30	0.50	3.41	0.15

DIXI 7532 XIDUR Z = 2				Aciers à outils et fontes trempées		45 - 55 HRC (Vc 250 - 350 m/min)	
D	Vc [m/min]	n [min -1]	Vf [mm/min]	ap [mm]	ae [mm]	Deff. [mm]	fz [mm]
0.2 - 1	250	79580	1110	0.02	0.05	0.28	0.007
1.5	250	53050	2120	0.03	0.07	0.42	0.02
2	250	39790	2390	0.04	0.09	0.56	0.03
3	250	26530	2120	0.05	0.11	0.77	0.04
4	250	19890	1990	0.07	0.15	1.04	0.05
5	250	15920	1910	0.12	0.20	1.53	0.06
6	250	13260	1860	0.15	0.25	1.87	0.07
8	250	9950	1790	0.20	0.30	2.50	0.09
10	250	7960	1750	0.25	0.40	3.12	0.11

DIXI 7532 XIDUR Z = 2				Aciers à outils et fontes trempées		55 - 65 HRC (Vc 100 - 200 m/min)	
D	Vc [m/min]	n [min -1]	Vf [mm/min]	ap [mm]	ae [mm]	Deff. [mm]	fz [mm]
0.2 - 1	130	41380	330	0.02	0.04	0.28	0.004
1.5	130	27590	390	0.03	0.05	0.42	0.007
2	130	20690	410	0.04	0.06	0.56	0.010
3	130	13790	410	0.05	0.07	0.77	0.015
4	130	10350	520	0.06	0.10	0.97	0.025
5	130	8280	500	0.08	0.16	1.25	0.030
6	130	6900	550	0.10	0.18	1.54	0.040
8	130	5170	520	0.15	0.20	2.17	0.050
10	130	4140	500	0.18	0.22	2.65	0.060

Micropulvérisation recommandée, émulsion déconseillée

Les valeurs n et Vf sont indicatives et devront être ajustées en fonction de la longueur L₂ de l'outil

Les valeurs n et Vf sont un point de départ, en fonction de la qualité de l'empreinte à produire (précision et état de surface) elles pourront être augmentées ou diminuées.

Si la broche ne permet pas la rotation recommandée du tableau, l'avance Vf doit être réduite proportionnellement.

Usiner autant que possible en avalant.



CONDITIONS DE COUPE

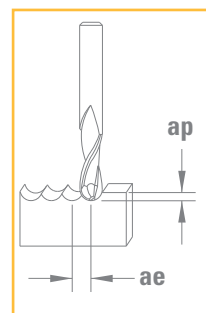

DIXI 7542 XIDUR Z = 2		Aciers à outils et fontes trempées			30-45 HRC		(Vc 400 - 500 m/min)	
D	Vc [m/min]	n [min ⁻¹]	Vf [mm/min]	ap [mm]	ae [mm]	Deff. [mm]	fz [mm]	
1		90000	1800	0.02	0.05	0.28	0.01	
1.5	320	67910	2720	0.04	0.06	0.48	0.02	
2	320	50930	3060	0.05	0.09	0.62	0.03	
3	320	33950	2720	0.07	0.13	1.08	0.04	
4	320	25470	2550	0.09	0.15	1.20	0.05	
5	320	20370	2850	0.15	0.25	1.71	0.07	
6	320	16980	2720	0.20	0.30	2.15	0.08	
8	320	12730	2550	0.25	0.35	2.78	0.10	
10	320	10190	3060	0.30	0.50	3.41	0.15	
12	320	8490	3400	0.40	0.60	4.31	0.20	

DIXI 7532 XIDUR Z = 2		Aciers à outils et fontes trempées			45 - 55 HRC		(Vc 250 - 350 m/min)	
D	Vc [m/min]	n [min ⁻¹]	Vf [mm/min]	ap [mm]	ae [mm]	Deff. [mm]	fz [mm]	
1	200	63660	890	0.02	0.05	0.28	0.007	
1.5	200	42440	1700	0.03	0.07	0.42	0.020	
2	200	31830	1910	0.04	0.09	0.56	0.030	
3	200	21220	1700	0.05	0.11	0.77	0.040	
4	200	15920	1590	0.07	0.15	1.04	0.050	
5	200	12730	1530	0.12	0.20	1.53	0.060	
6	200	10610	1490	0.15	0.25	1.87	0.070	
8	200	7960	1430	0.20	0.30	2.50	0.090	
10	200	6370	1400	0.25	0.40	3.12	0.110	
12	200	5310	1380	0.30	0.50	3.75	0.130	

DIXI 7532 XIDUR Z = 2		Aciers à outils et fontes trempées			55 - 65 HRC		(Vc 100 - 200 m/min)	
D	Vc [m/min]	n [min ⁻¹]	Vf [mm/min]	ap [mm]	ae [mm]	Deff. [mm]	fz [mm]	
1	100	31830	250	0.02	0.04	0.28	0.004	
1.5	100	21220	300	0.03	0.05	0.42	0.007	
2	100	15920	320	0.04	0.06	0.56	0.010	
3	100	10610	320	0.05	0.07	0.77	0.015	
4	100	7960	400	0.06	0.10	0.97	0.025	
5	100	6370	380	0.08	0.16	1.25	0.030	
6	100	5310	420	0.10	0.18	1.54	0.040	
8	100	3980	400	0.15	0.20	2.17	0.050	
10	100	3180	380	0.18	0.22	2.65	0.060	
12	100	2650	420	0.20	0.25	3.07	0.080	

Micropulvérisation recommandée, émulsion déconseillée

Les valeurs **n** et **Vf** sont un point de départ, en fonction de la qualité de l'empreinte à produire (précision et état de surface) elles pourront être augmentées ou diminuées.

Si la broche ne permet pas la rotation recommandée du tableau, l'avance **Vf** doit être réduite proportionnellement.

Usiner autant que possible en avalant.

CONDITIONS DE COUPE

DIXI 7520 XIDUR Z = 3-12		Aciers à outils et fontes trempées			45 - 55 HRC (Vc 30 - 70 m/min)		
D ₁	Z	Vc (m/min)	n (min -1)	Vf (mm/min)	ap (mm)	ae (mm)	fz (mm)
0.4 - 0.9	3	30	-	-	0.03 x D ₁	1 x D ₁	0.001 - 0.002
1	4	40	12800	125	0.04	1.00	0.002
1.5	4	40	8500	125	0.05	1.50	0.0035
2	5	40	6300	125	0.07	2.00	0.004
3	5	40	4240	150	0.12	3.00	0.007
4	5	40	3180	160	0.15	4.00	0.010
6	6	40	2120	190	0.20	6.00	0.015
8	6	40	1590	190	0.25	8.00	0.020
10	6	40	1270	190	0.30	10.00	0.025
12	8	40	1060	210	0.40	12.00	0.025
16	10	40	800	240	0.60	16.00	0.030

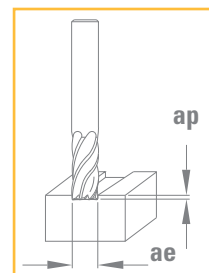

DIXI 7520 XIDUR Z = 3-12		Aciers à outils et fontes trempées			45 - 55 HRC (Vc 150 - 250 m/min)		
Ø	Z	Vc (m/min)	n (min -1)	Vf (mm/min)	ap (mm)	ae (mm)	fz (mm)
0.4 - 0.9	3	150	-	-	1 x D ₁	0.03 x D ₁	0.001 - 0.002
1	4	200	63700	640	1.00	0.04	0.002
1.5	4	200	42450	640	1.50	0.05	0.0035
2	5	200	32000	640	2.00	0.07	0.004
3	5	200	21300	750	3.00	0.12	0.007
4	5	200	15920	800	4.00	0.15	0.010
6	6	200	10610	950	6.00	0.20	0.015
8	6	200	7960	960	8.00	0.25	0.020
10	6	200	6370	960	10.00	0.30	0.025
12	8	200	5310	1060	12.00	0.40	0.025
16	10	200	3980	1190	16.00	0.60	0.030

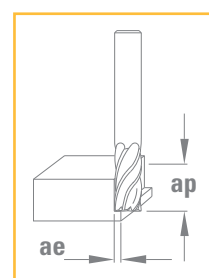

DIXI 7520 XIDUR Z = 3-12		Aciers à outils et fontes trempées			55 - 65 HRC (Vc 12 - 40 m/min)		
Ø	Z	Vc (m/min)	n (min -1)	Vf (mm/min)	ap (mm)	ae (mm)	fz (mm)
0.4 - 0.9	3	12	-	-	0.03 x D ₁	1 x D ₁	0.001 - 0.002
1	4	15	4700	45	0.03	1.00	0.002
1.5	4	15	3180	45	0.03	1.50	0.0035
2	5	15	2300	45	0.04	2.00	0.004
3	5	15	1600	55	0.05	3.00	0.007
4	5	15	1190	60	0.06	4.00	0.010
6	6	15	800	70	0.09	6.00	0.015
8	6	15	600	70	0.12	8.00	0.020
10	6	15	480	70	0.15	10.00	0.025
12	8	15	400	80	0.18	12.00	0.025
16	10	15	300	90	0.20	16.00	0.030

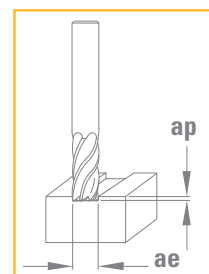

DIXI 7520 XIDUR Z = 3-12		Aciers à outils et fontes trempées			55 - 65 HRC (Vc 60 - 120 m/min)			Ø
Z	Vc	n (m/min)	Vf (min -1)	ap (mm/min)	ae (mm)	fz (mm)	(mm)	
0.4 - 0.9	3	60	-	-	1 x D ₁	0.03 x D ₁	0.001 - 0.002	
1	4	80	25500	250	1.00	0.03	0.002	
1.5	4	80	17000	250	1.50	0.035	0.0035	
2	5	80	12700	250	2.00	0.04	0.004	
3	5	80	8500	290	3.00	0.05	0.007	
4	5	80	6370	320	4.00	0.06	0.010	
6	6	80	4240	380	6.00	0.09	0.015	
8	6	80	3180	380	8.00	0.12	0.020	
10	6	80	2550	380	10.00	0.15	0.025	
12	8	80	2120	420	12.00	0.18	0.025	
16	10	80	1590	480	16.00	0.20	0.030	

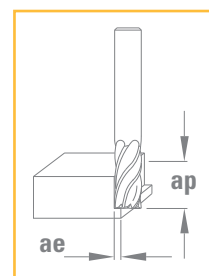

Micropulvérisation recommandée, émulsion déconseillée



CONDITIONS DE COUPE

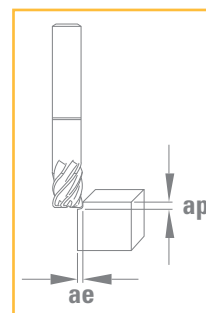

DIXI 7070 XIDUR Z = 4-6		Aciers à outils et fontes trempées			30-45 HRC	(Vc 150 - 200 m/min)	
D ₁	Z	Vc [m/min]	n [min ⁻¹]	Vf [mm/min]	ap [mm]	ae [mm]	fz [mm]
3	4	150	15900	3800	0.20	0.80	0.06
4	4	150	11940	4300	0.25	0.85	0.09
5	4	150	9550	4580	0.30	0.90	0.12
6	4	150	7960	4460	0.35	1.00	0.14
8	6	150	5970	5730	0.40	1.10	0.16
10	6	150	4770	5150	0.45	1.30	0.18
12	6	150	3980	4780	0.50	1.50	0.20

DIXI 7070 XIDUR Z = 4-6		Aciers à outils et fontes trempées			45 - 55 HRC	(Vc 130 - 170 m/min)	
D ₁	Z	Vc [m/min]	n [min ⁻¹]	Vf [mm/min]	ap [mm]	ae [mm]	fz [mm]
3	4	130	13700	2750	0.15	0.70	0.05
4	4	130	10350	3310	0.20	0.75	0.08
5	4	130	8280	3310	0.25	0.75	0.10
6	4	130	6900	3040	0.30	0.80	0.11
8	6	130	5170	3720	0.40	0.80	0.12
10	6	130	4140	3230	0.42	1.00	0.13
12	6	130	3450	2900	0.45	1.20	0.14

DIXI 7070 XIDUR Z = 4-6		Aciers à outils et fontes trempées			55 - 65 HRC	(Vc 100 - 130 m/min)	
D ₁	Z	Vc [m/min]	n [min ⁻¹]	Vf [mm/min]	ap [mm]	ae [mm]	fz [mm]
3	4	100	10600	500	0.08	0.20	0.010
4	4	100	7960	640	0.10	0.25	0.020
5	4	100	6370	890	0.12	0.28	0.035
6	4	100	5310	850	0.15	0.30	0.040
8	6	100	3980	1190	0.18	0.32	0.050
10	6	100	3180	1140	0.20	0.35	0.060
12	6	100	2650	1270	0.25	0.40	0.080

